

# **The Pattern of Truth**

**Composite**

**Heard Lowry**

## Quote

**There is nothing  
that makes its way  
more directly to the soul  
than beauty.**

**Joseph Addison**

# Outline of the Class

- **Introduction**
- **The Perception Process**
- **Pattern Structure**
- **Critical Patterns**
  - Law
  - Church
  - Family
  - God' Goodness
  - Personal
- **Developing the Pattern God Wants in Us**
- **Summary**

# The purpose of this class

- We want to use the theme of patterns to provoke thought about God's Truth, and look at it in fresh and new ways
  - Like trying to match colors by carrying around a plaid swatch of cloth
  - Like seeing the same model as your new car
- To Recognize the Core of God's Truth
  - What is the Real Thing? (Coke)
  - Recognize God (the Good in the Pattern)
  - Discriminate Reality from Illusion
- This is a theme study: Use the pattern theme as a lens to examine more closely the Bible and its Truth
  - we sometimes think that we know it so well



**Introduction: the delivery of the pattern of God's temple**

# The purpose of this class

We're hunting patterns that trigger our thought



Kill the wabbit!

The pattern must fit what we really need

# The purpose of this class

There can be a struggle between two patterns.



We have to know what we are hunting for!

# The purpose of this class

1

The world rearranges the patterns sometimes.



We have to be able to tell the difference.

# The purpose of this class – the song in your heart<sup>1</sup>

## Do you have a favorite song?



- it has a pattern of notes and rhythms
- it stays in your heart, and you keep singing it
- you remember it (Tommy)
- it gives you goosebumps or chills when you hear it (band)
- you want to keep having that feeling

## We try to keep that feeling sometimes with the wrong things

- comfort food or entertainment
- thrill rides and other activities
- perhaps drugs

I want to help you see the pattern of Truth and God with such power that it will stay with you forever!



# The purpose of this class – the depths of Truth <sup>1</sup>

Deacons... must keep hold of the **deep truths** of the faith...

1 Timothy 3:8-9

Paul, a servant of God and an apostle of Jesus Christ  
for the faith of God's elect and the knowledge  
of **the truth that leads to godliness** —

Titus 1:1

Jesus answered, "I am the way and the **truth** and the life.

No one comes to the Father except through me.

John 14:6

God is spirit, and his worshipers

must worship in spirit and in **truth**.

John 4:24

# The purpose of this class – the depths of Truth

1



**We must stand in awe of that Truth.**

# The pattern on the mountain - overview

1

**God directed Moses to build the tabernacle according to the pattern He gave Him.**

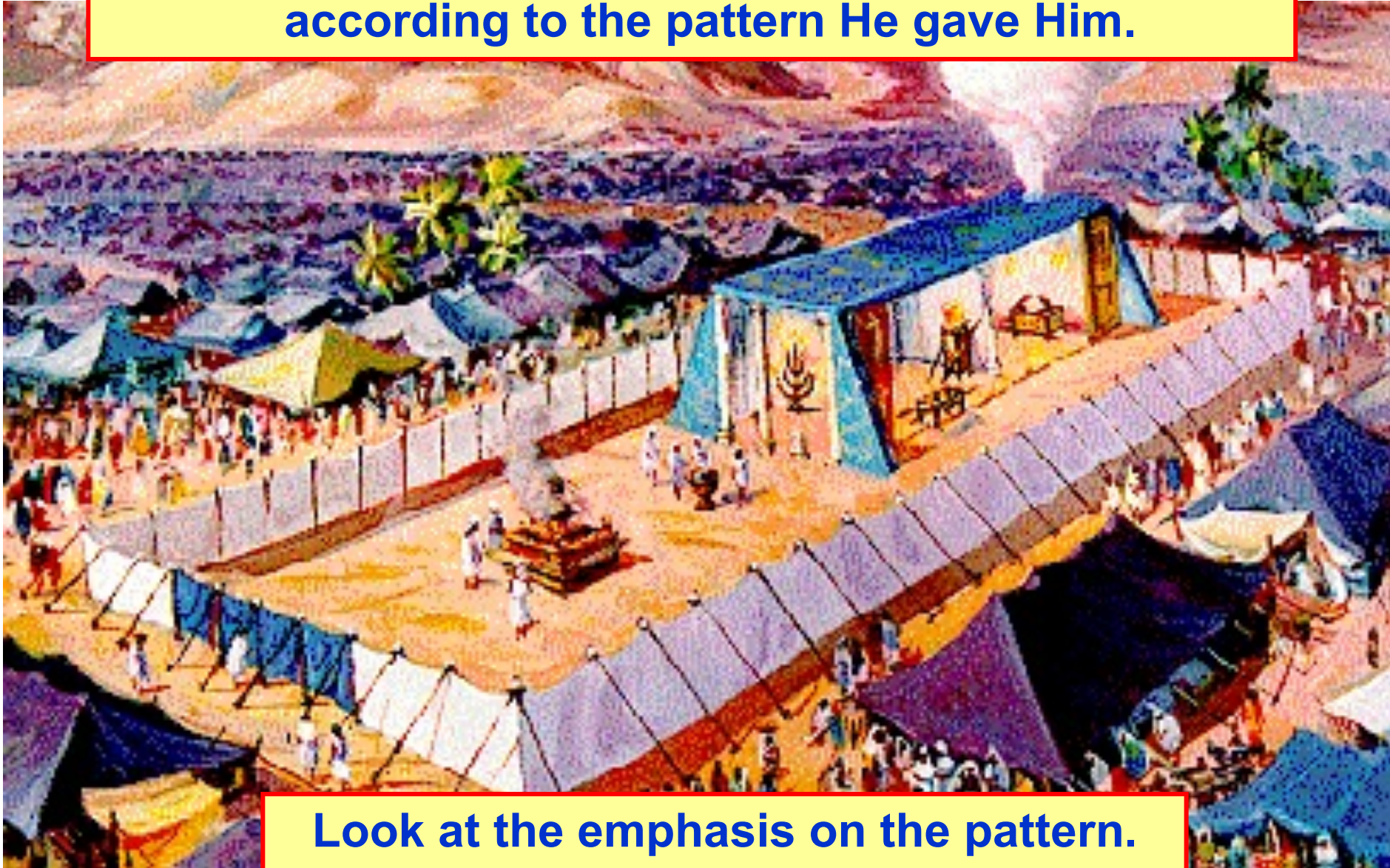

**Look at the emphasis on the pattern.**

# The pattern on the mountain (1)

The LORD said to Moses... Make this tabernacle and all its furnishings **exactly like the pattern** I will show you.

Have them make a chest of acacia wood -- two and a half cubits long, a cubit and a half wide, and a cubit and a half high. Overlay it with pure gold, both inside and out, and make a gold molding around it. Cast four gold rings for it and fasten them to its four feet, with two rings on one side and two rings on the other. Then make poles of acacia wood and overlay them with gold. Insert the poles into the rings on the sides of the chest to carry it. The poles are to remain in the rings of this ark; they are not to be removed. Then put in the ark the Testimony, which I will give you.

Exodus 25:9-16

## The pattern on the mountain (2) preparing a place to meet God

Make an atonement cover of pure gold -- two and a half cubits long and a cubit and a half wide. And make two cherubim out of hammered gold at the ends of the cover. Make one cherub on one end and the second cherub on the other; make the cherubim of one piece with the cover, at the two ends. The cherubim are to have their wings spread upward, overshadowing the cover with them. The cherubim are to face each other, looking toward the cover. Place the cover on top of the ark and put in the ark the Testimony, which I will give you.

There, above the cover between the two cherubim that are over the ark of the Testimony, **I will meet with you and give you all my commands for the Israelites.**

**Exodus 25:16-**

# The pattern on the mountain (3)

Make a table of acacia wood... make its plates and dishes of pure gold, as well as its pitchers and bowls... a lampstand of pure gold...

See that you make them **according to the pattern** shown you on the mountain.

Make the tabernacle with ten curtains of finely twisted linen and blue, purple and scarlet yarn, with cherubim worked into them by a skilled craftsman...

Set up the tabernacle **according to the plan** shown you on the mountain.

Build an altar of acacia wood... Make the altar hollow, out of boards. It is to be made **just as you were shown** on the mountain. Make a courtyard for the tabernacle.

Exodus 25:22-40, Exodus 26:29-30, Exodus 27:8-9

## The pattern on the mountain (4) preparing a place to meet God

Then the LORD said to Moses,

"Take fragrant spices... and make a fragrant blend of incense, the work of a perfumer.

It is to be salted and pure and sacred.

Grind some of it to powder and place it in front of the Testimony in the Tent of Meeting, **where I will meet with you.**

It shall be most holy to you.

Do not make any incense with this **formula** for yourselves; consider it holy to the LORD.

Whoever makes any like it to enjoy its fragrance must be cut off from his people."

Exodus 30:34-38

# The pattern on the mountain (5)

Then the LORD said to Moses...

I have given skill to all the craftsmen to make everything I have commanded you: the Tent of Meeting, the ark of the Testimony with the atonement cover on it, and all the other furnishings of the tent -- the table and its articles, the pure gold lampstand and all its accessories, the altar of incense, the altar of burnt offering and all its utensils, the basin with its stand -- and also the woven garments, both the sacred garments for Aaron the priest and the garments for his sons when they serve as priests, and the anointing oil and fragrant incense for the Holy Place.

They are to **make them just as I commanded you.**"

**Exodus 31:6-11**



## The pattern on the mountain (6)

- garments... as the LORD commanded Moses.
- ephod... as the LORD commanded Moses.
- memorial stones... as the LORD commanded Moses.
- breastpiece... as the LORD commanded Moses.
- robe... as the LORD commanded Moses.
- tunics, headbands, undergarments, sash... as the LORD commanded Moses.
- sacred diadem... as the LORD commanded Moses.

So all the work on the tabernacle, the Tent of Meeting, was completed. The Israelites did everything just as the LORD commanded Moses.

Moses inspected the work and saw that they had done it just as the LORD had commanded. So Moses blessed them.

# The pattern on the mountain (7)

Moses did everything just **as the LORD commanded him.**

Then he spread the tent over the tabernacle and put the covering over the tent, **as the LORD commanded him.**

Then he brought the ark into the tabernacle... **as the LORD commanded him.**

Moses placed the table... and set out the bread on it before the LORD, **as the LORD commanded him.**

He placed the lampstand... and set up the lamps before the LORD, **as the LORD commanded him.**

Moses placed the gold altar... and burned fragrant incense on it, **as the LORD commanded him.**

He set the altar... and offered on it burnt offerings... **as the LORD commanded him.**

He placed the basin... for washing, **as the LORD commanded Moses.**

# The pattern on the mountain – God's Presence

1

And so Moses finished the work.

Then the cloud covered the Tent of Meeting, and **the glory of the LORD filled the tabernacle.**

Moses could not enter the Tent of Meeting because the cloud had settled upon it, and **the glory of the LORD filled the tabernacle.**

In all the travels of the Israelites, whenever the cloud lifted from above the tabernacle, they would set out; but if the cloud did not lift, they did not set out -- until the day it lifted.

So **the cloud of the LORD** was over the tabernacle by day, and fire was in the cloud by night, in the sight of all the house of Israel during all their travels.

**Exodus 40:33-38**

# The pattern on the mountain – the lampstand

**This is how the lampstand was made:**

**It was made of hammered gold –  
from its base to its blossoms.**

**The lampstand was made **exactly like the pattern**  
the LORD had shown Moses.**

**Numbers 8:4**

# The pattern on the mountain – NT summary

**Our forefathers had the  
tabernacle of the Testimony with them in the desert.**

**It had been made as God directed Moses,  
according to the pattern he had seen.**

**Acts 7:44**

# The pattern on the mountain – a copy of the True <sup>1</sup>

They serve at a sanctuary that is a **copy and shadow** of what is in heaven.

This is why Moses was warned when he was about to build the tabernacle:

"See to it that you make everything **according to the pattern** shown you on the mountain."

Hebrews 8:5

**It is an inherent property of intelligence  
that it can jump out of the task  
which it is performing,  
and survey what it has done;  
  
it is always looking for,  
and often finding,  
patterns.**

**Douglas Hofstadter**

# The pattern on the mountain – comments (1)

2

- **God demanded absolute adherence to the plan for the tabernacle**
- **Moses led the people and they delivered the tabernacle according to the instructions**

- **What was God really after?**
  - **A perfect tabernacle?**
  - **Could this physical perfection really mean anything to God?**
  - **"The multitude of your sacrifices-- what are they to me?" says the LORD. "I have more than enough of burnt offerings, of rams and the fat of fattened animals; I have no pleasure in the blood of bulls and lambs and goats. (Isaiah 1:11)**
- **Did the pattern God presented for the tabernacle, or its building exactly according to the pattern, help people to develop a better relationship with God?**



# The pattern on the mountain – comments (2)

- The patriarchs had a personal relationship with God
- The people of Israel in general were not ready for the power of proximity to God
- The formal, rigid pattern kept God beyond their reach
- The people needed the priesthood to connect them to God
- God wanted a people, but they had to want Him as their God

**Is obedience without love pleasing to God?**

# The pattern on the mountain – comments (3)

- The law was given before the people were able to see the importance of the relationship –  
and was given to promote the development of the relationship
- The law alone does not have the proper depth to probe the heart
- The human high priests did not have the power to maintain the personal connection with God and His people

**OT: LAW**

**NT: RELATIONSHIP**

**What is the Pattern that God really wants from us?**

# Using the pattern to establish righteousness

- **The 10 Commandments were a pattern to follow**
  - They were a foundation to build on
  - We must not forget how we must act towards our neighbor
- **The prophets were involved in pointing to a new, more personal pattern**
  - They began unfolding message to show the coming pattern
- **Pharisees missed the point, and tried to defend their pattern to Jesus and His followers**
- **We may use the pattern of the structure we perceive to establish our righteousness**
  - Does it really match the pattern that God is after?

# The pattern on the mountain – a copy of the True <sup>2</sup>

They serve at a sanctuary that is a **copy and shadow** of what is in heaven.

This is why Moses was warned when he was about to build the tabernacle:

"See to it that you make everything **according to the pattern** shown you on the mountain."

Hebrews 8:5

# How the Tabernacle Pattern Changed (1)

When Christ came as high priest of the good things that are already here, he went through **the greater and more perfect tabernacle that is not man-made**, that is to say, not a part of this creation.

He did not enter by means of the blood of goats and calves; but he entered the **Most Holy Place** once for all by his own blood, having obtained eternal redemption.

... He sprinkled with the blood both **the tabernacle and everything used in its ceremonies**. In fact, the law requires that nearly everything be cleansed with blood...

Hebrews 9:11-12, 21

Hebrews is all about the superiority of Christ to the pattern established in the Old Testament

## How the Tabernacle Pattern Changed (2)

It was necessary, then, for the **copies of the heavenly things** to be purified with these sacrifices, but the **heavenly things themselves** with better sacrifices than these.

For Christ did not enter a **man-made sanctuary** that was only a **copy** of the true one; he entered **heaven** itself, now to appear for us in God's presence.

Nor did he enter **heaven** to offer himself again and again, the way the high priest enters the Most Holy Place every year with blood that is not his own.

... He has appeared **once** for all at the end of the ages to do away with sin by the sacrifice of Himself.

Hebrews 9:22-26

Not just a copy in place, but in time.

# The Law is Only a Shadow

The law is only a **shadow** of the good things that are coming – not the **realities** themselves.

For this reason it can **never**, by the same sacrifices repeated endlessly year after year, **make perfect** those who draw near to worship.

Day after day every priest stands and performs his religious duties; again and again he offers the same sacrifices, which can never take away sins.

But when **this priest** [*Christ*] had offered for all time one sacrifice for sins, he sat down at the right hand of God [*finished*].

Hebrews 10:1, 11-12

Christ's effectiveness was infinitely superior to the old pattern (once vs endless).

# Outline of the Class

- Introduction
- **The Perception Process**
- **Pattern Structure**
- **Critical Patterns**
  - Law
  - Church
  - Family
  - God's Goodness
  - Personal
- **Developing the Pattern God Wants in Us**
- **Summary**



**To a world steeped in the barbarity  
of child sacrifice and multiple gods...  
the book of Genesis revealed a world  
never before envisioned.**

**There was order,  
and there was the possibility of progress.**

**Gerald L. Schroeder**

# Can we pick the right thread out of the pattern? <sup>3</sup>

- **Narrow is the way and few there be that find it (Matthew 7:13-14, Luke 13:24)**
  - Many people do not get the point
  - Many people cannot see the thread of truth
  - Many people cannot see the forest for the trees
- **We need to be able to see the thread of Good (God)**

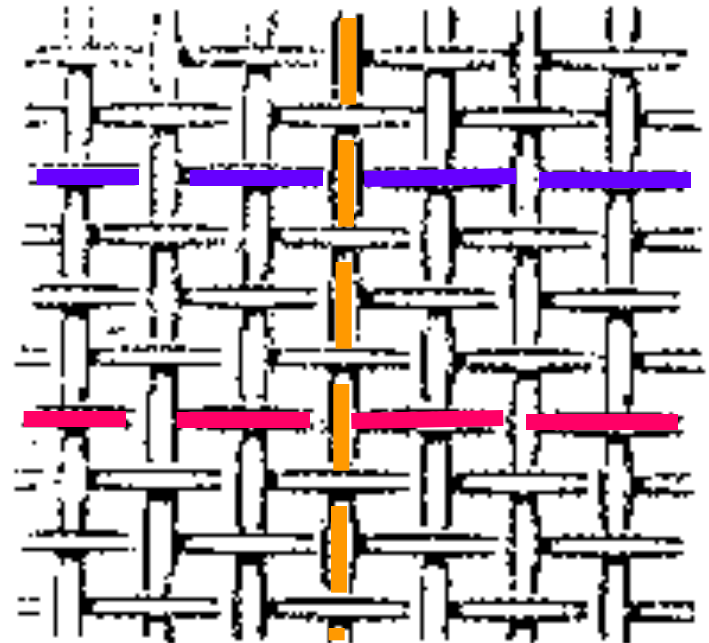
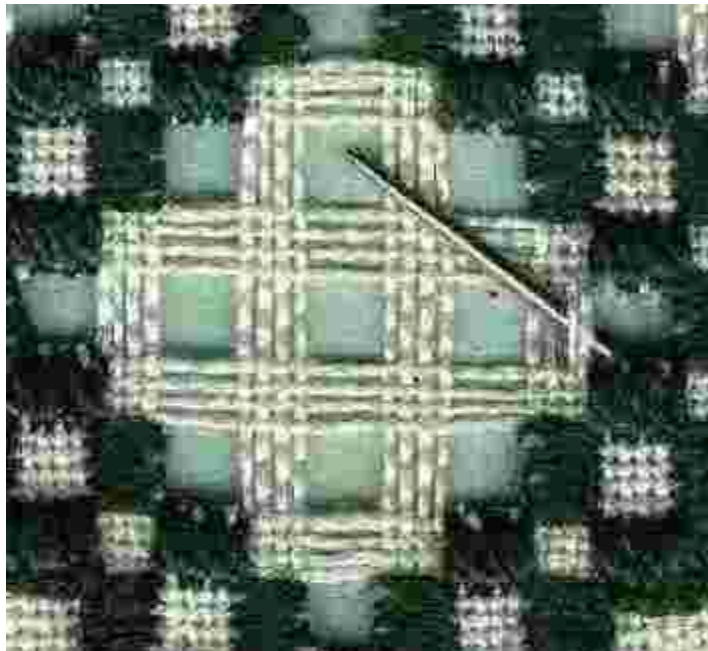

# Do we need spiritual glasses?

For this very reason, make every effort to add  
to your faith goodness;  
and to goodness, knowledge;  
and to knowledge, self-control;  
and to self-control, perseverance;  
and to perseverance, godliness;  
and to godliness, brotherly kindness;  
and to brotherly kindness, love.

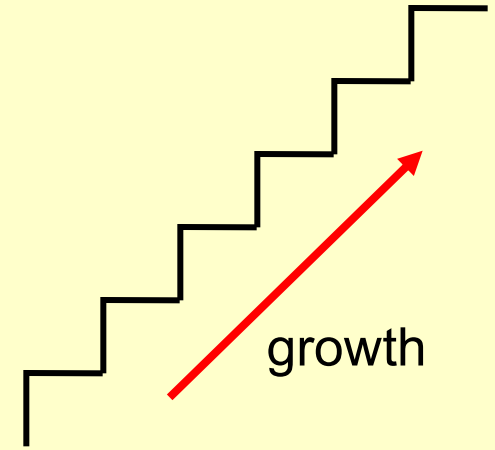

For if you possess these qualities in increasing measure, they will keep you from being ineffective and unproductive in your knowledge of our Lord Jesus Christ.

But if anyone does not have them,  
he is **nearsighted and blind**,  
and has forgotten  
that he has been cleansed from his past sins.



2 Peter 1:5-9

# Can we perceive properly the real pattern of truth?<sup>8</sup>

- How clear is God's pattern?
- Does it come in and out of focus?

**Warning: some images in this class may be disturbing!**

# Can we perceive properly the real pattern of truth?

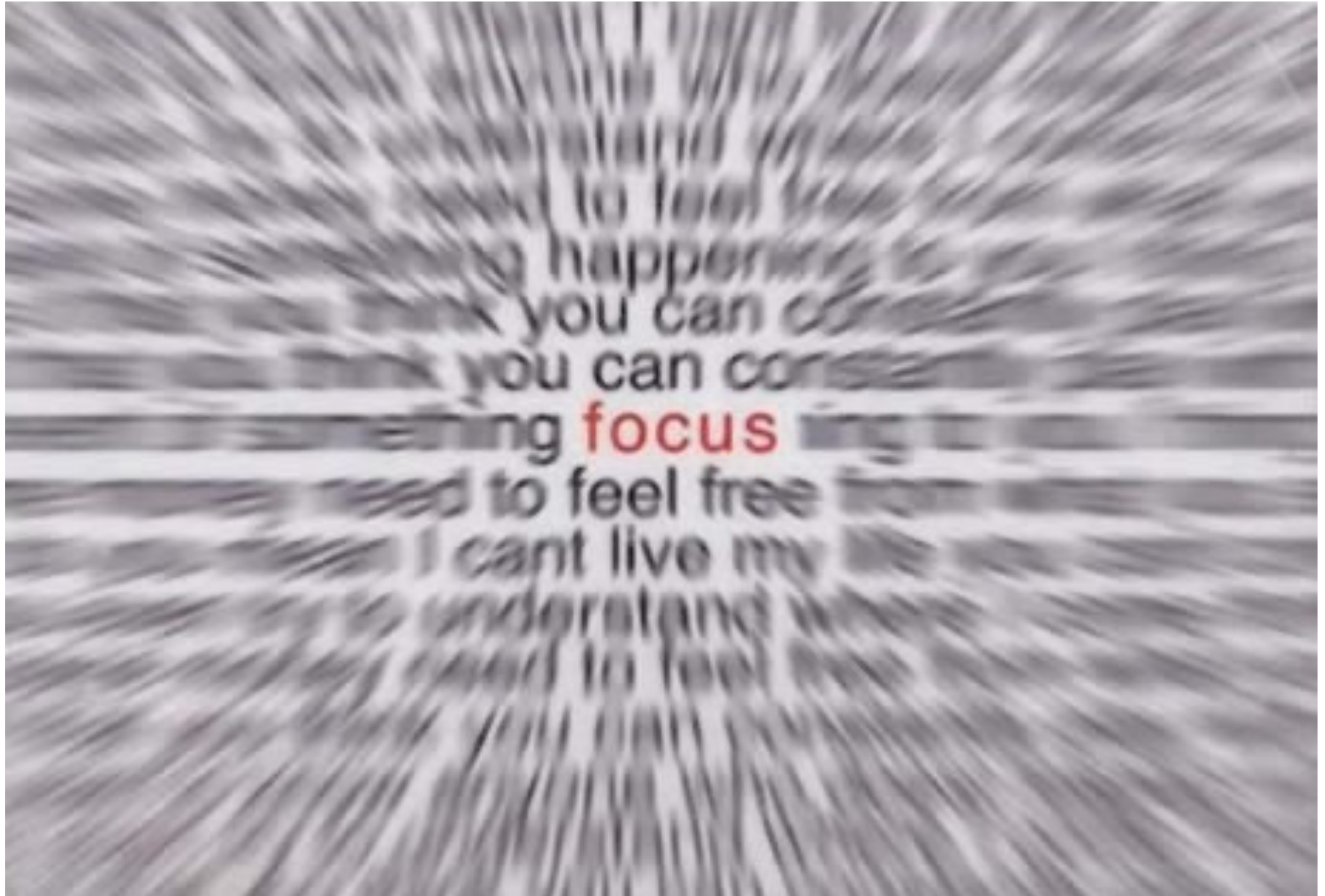

# Can we perceive properly the real pattern of truth?

- How clear is God's pattern?
  - Do we have a beam or a speck in our eye?

"Why do you look at the speck of sawdust in your brother's eye and pay no attention to the plank in your own eye? How can you say to your brother, 'Let me take the speck out of your eye,' when all the time there is a plank in your own eye? You hypocrite, first take the plank out of your own eye, and then you will see clearly to remove the speck from your brother's eye.

**Matthew 7:3-5**

**We have one or the other!**

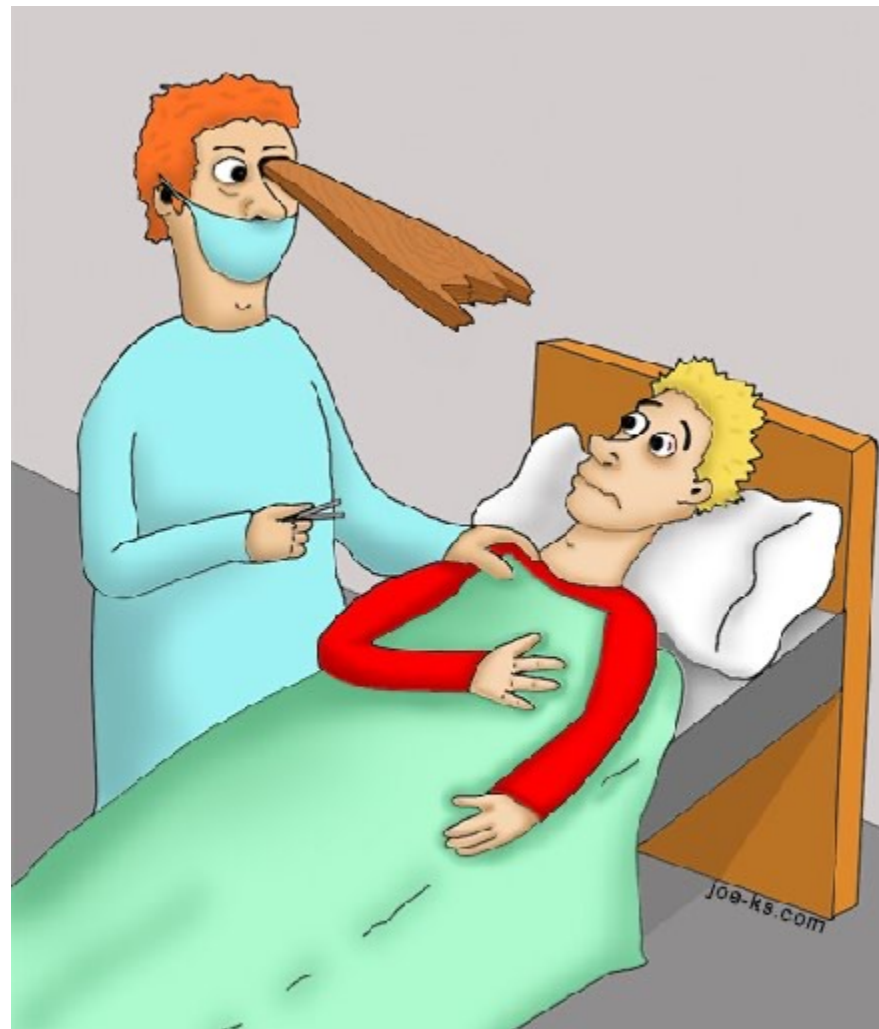

Let me take that speck out of your eye.

# What do patterns do for you?

- help organize
- help understand
- inspire
- please us aesthetically
- attract our attention
- guide us (keep us from getting lost)
- help us communicate
- to align our lives properly (best results, less friction)
- to make you comfortable (like your home or nation);
- to refresh by changing

# What if we didn't "see" patterns?

**This would take a lot out of life...**

- **My Dad would talk in amazement about the pattern of contrails in the sky**
  - **Where were they all going?**
  - **Think of the patterns he sees now in heaven!**





# What are the inputs that develop our own pattern?<sup>3</sup>

- the way our brains have been made to work
- instincts programmed in
- rational thought (developed through patterns)
- life experience
- secular education
- scripture

# What do we use patterns for?

- sewing
- recipes
- maps
- instructions, procedures
- art
- identification
- search
- communication
- flag

**DUSTIES**

**Dusties**  
 1 cup whole wheat flour  
 1/3 cup shortening  
 Pinch of salt  
 4 tablespoons water  
 Your choice of favorite preserves  
 Powdered sugar

Cut shortening into flour until the texture of mix is crumbly. Add 4 tablespoons water and work into a dough. On floured surface roll out dough to 1/8 inch thickness. Cut 4 inch circles, the recipe should yield eight circles. Put 3/4 tablespoon of preserves in the center of each circle then fold circle in half. Crimp edges of half circle with tines of fork to seal.  
 Bake at 425 degrees for 10-12 minutes. Dust with powdered sugar after baking.

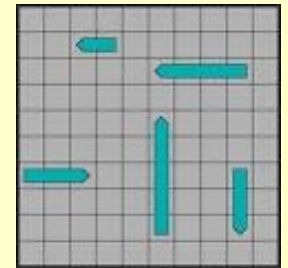
# A, a

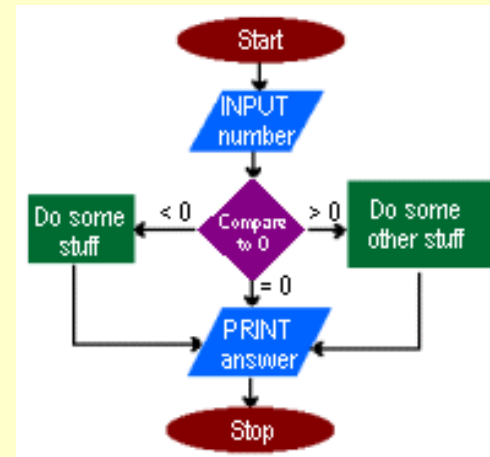
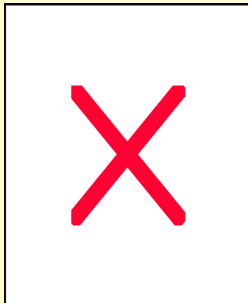
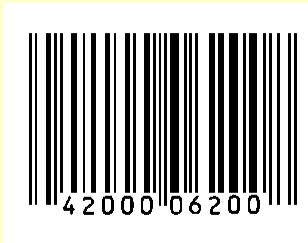

<http://phone.seeingwithsound.com>

# Example of Religious Image Patterns

- The Cross



- The crucifix

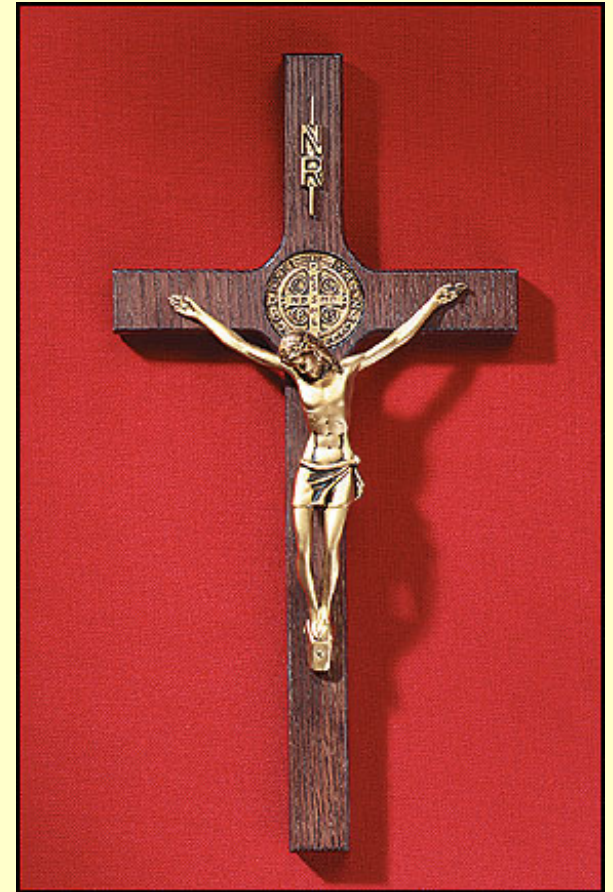

**Not our “icon”, but it should still be thought-provoking**

# Patterns be Used in a Good or Bad Way

**"You shall not make for yourself an idol  
[KJV: graven image]  
in the form of anything in heaven above  
or on the earth beneath or in the waters below.  
You shall not bow down to them or worship them;  
for I, the LORD your God, am a jealous God...**

**Exodus 20:4-5**

- **Is using an icon like a cross or crucifix  
worship of a graven image,  
or just a tool to use as a reminder?**
- **The Jews and Muslims used patterns  
to keep from using “graven images”  
They needed a way to decorate  
without using images**

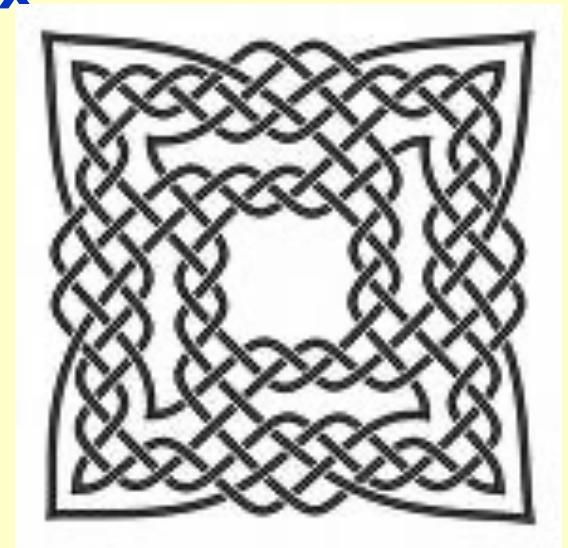

# Example of Patterns used to Build

- **Blueprint** – used to build things to make our lives better



# There was a Plan for the Temple, Too

Consider now, for the LORD has chosen you [Solomon] to build a temple as a sanctuary.

Be strong and do the work."

Then David gave his son Solomon the **plans** for the portico of the temple, its buildings, its storerooms, its upper parts, its inner rooms and the place of atonement.

He gave him the **plans** of all that the Spirit had put in his mind for the courts of the temple of the LORD and all the surrounding rooms...

# Our Building Must be Approved by God



Copyright © 2006 Creators Syndicate, Inc.

**Unless the Lord build the house,  
its builders labor in vain.**

**Psalm 127:1**

# The pattern must be understandable

How would you build this?

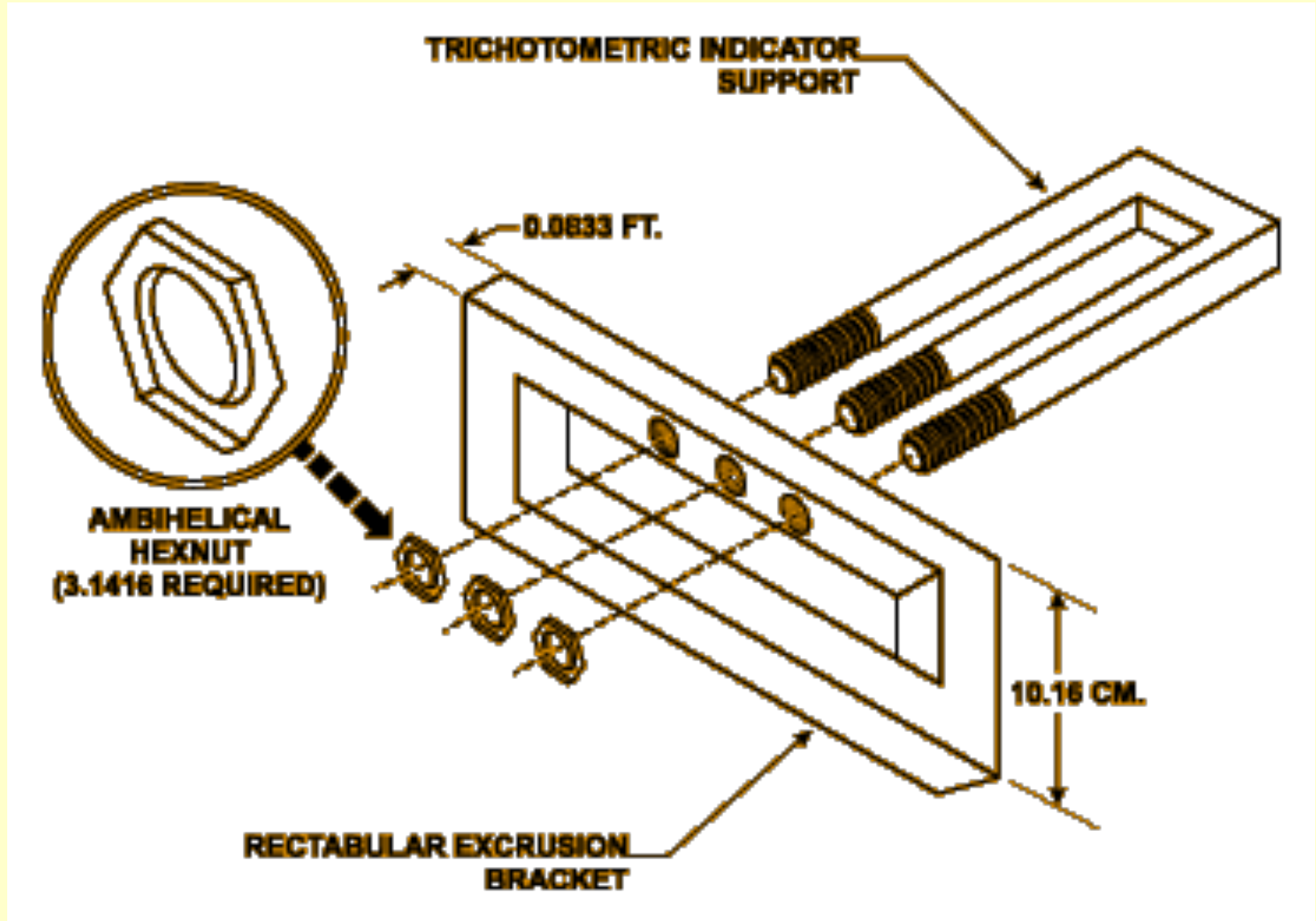



# The Environment must be Right

Car parts were made according to a strict pattern. But early on the parts didn't work and weren't interchangeable. Finally the problem was discovered: the parts wouldn't fit because they were made at different temperatures.

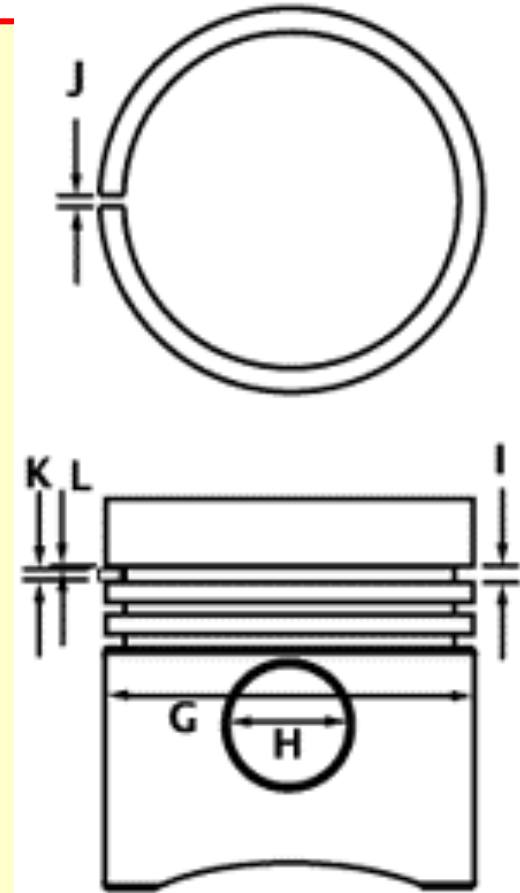

This proves that even with a strict pattern, the environment must be right.

This also applies to the pattern of Good in our heart.

# Creation:

## The Pattern of Design and the Designer

**Many people look right into the face  
of the obvious design characteristics  
of the universe, the earth, and life –  
but do not see the presence of God.**

**We must test our perception capabilities.**

# The Pattern of Creation

**The Universe is full of Patterns  
that were Created by the Great Designer**

**The laws of physics show the beauty of its organization.**

**... according to the Bible,  
the universe was created  
with certain divinely chosen ground rules.**

**Gerald L. Schroeder**

# The Periodic Table

The Periodic table shows the organization of the elements.

The periodic table is color-coded by groups:

- alkali metals (grey)
- alkaline earth metals (green)
- transitional metals (yellow)
- other metals (pink)
- nonmetals (cyan)
- noble gases (orange)

Callout for Silicon (Si):

- atomic number: 14
- atomic weight: 28.09
- symbol: Si
- name: Silicon
- physical state: solid
- color: black
- state: liquid
- color: blue
- state: gas
- color: red
- state: synthetically prepared
- color: red
- state: more stable isotope

1	2											3	4	5	6	7	8	9	10	11	12		
H	He											B	C	N	O	F	Ne						
Li	Be											Al	Si	P	S	Cl	Ar						
Na	Mg											Ga	Ge	As	Se	Br	Kr						
K	Ca	Sc	Ti	V	Cr	Mn	Fe	Co	Ni	Cu	Zn	Ga	Ge	As	Se	Br	Kr						
Rb	Sr	Y	Zr	Nb	Mo	Tc	Ru	Rh	Pd	Ag	Cd	In	Sn	Sb	Te	I	Xe						
Cs	Ba	La	Hf	Ta	W	Re	Os	Ir	Pt	Au	Hg	Tl	Pb	Bi	Po	At	Rn						
Fr	Ra	Ac	Rf	Ha	Sg	Ns	Hs	Mt										(113)	(114)	(115)	(116)	(117)	(118)

Lanthanide series →

58	59	60	61	62	63	64	65	66	67	68	69	70	71
Ce	Pr	Nd	Pm	Sm	Eu	Gd	Tb	Dy	Ho	Er	Tm	Yb	Lu
Cerium	Praseodymium	Neodymium	Promethium	Samarium	Europium	Gadolinium	Terbium	Dysprosium	Holmium	Erbium	Thulium	Ytterbium	Lutetium

Actinide series →

90	91	92	93	94	95	96	97	98	99	100	101	102	103
Th	Pa	U	Np	Pu	Am	Cm	Bk	Cf	Es	Fm	Md	No	Lr
Thorium	Protactinium	Uranium	Neptunium	Plutonium	Americium	Curium	Berkelium	Californium	Einsteinium	Fermium	Mendelevium	Nobelium	Livermorium

# The Anthropic Principle

**Man (life) could not survive in a universe in which one or another of the fundamental dimensionless constants of physics is altered by a few percent one way or the other.**

**Nuclear forces: slight differences would have made atoms impossible.**

**Water floats when it freezes (unique properties of the hydrogen atom)**

**The synthesis of carbon is related to an astonishing coincidence in the ratio of the strong force to electromagnetism.**

**The fine structure constant – a slight difference and the atoms would not have the same structure**

# The Projection of God's Pattern on Creation

We are told that **two** aspects of a transcendent infinity labeled as God have been “condensed” and **projected** into our spatially and temporally finite universe.

One is a revelation,  
written in words,  
that we call the Bible.

The other reveals itself in the wonders of nature  
and the laws by which nature functions.

Gerald L. Schroeder

# DNA: The Pattern of Life

One of the great discoveries of the basis of Life was the determination that the information-carrying molecule, DNA, was in the form of a double-helix.

And God said, "Let the land produce living creatures according to their kinds... each according to its kind." And it was so. [similar for all life] **Genesis 1:24**

The Double-Helix Structure of DNA

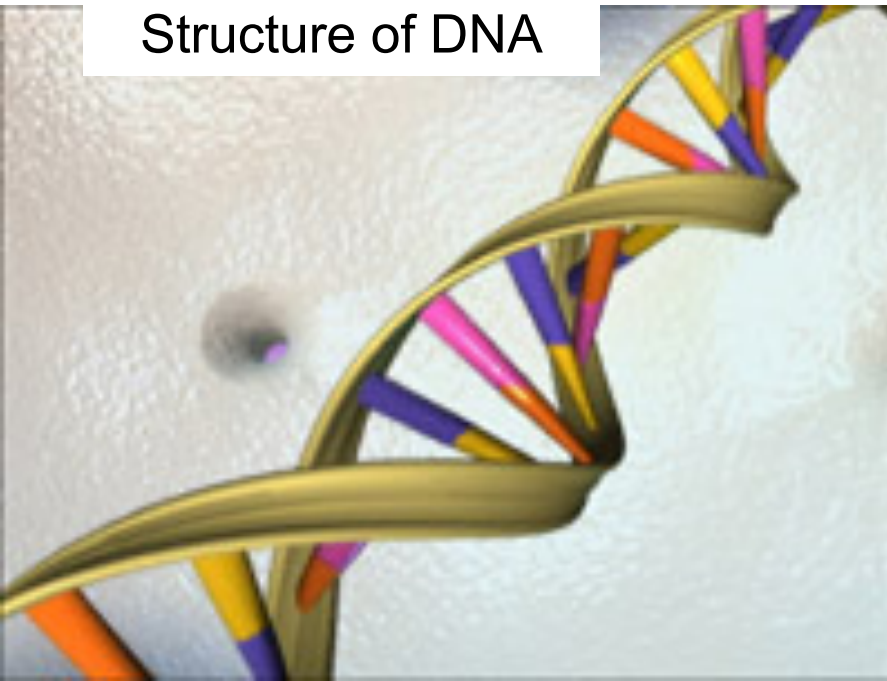

X-ray Diffraction Pattern of the DNA Molecule

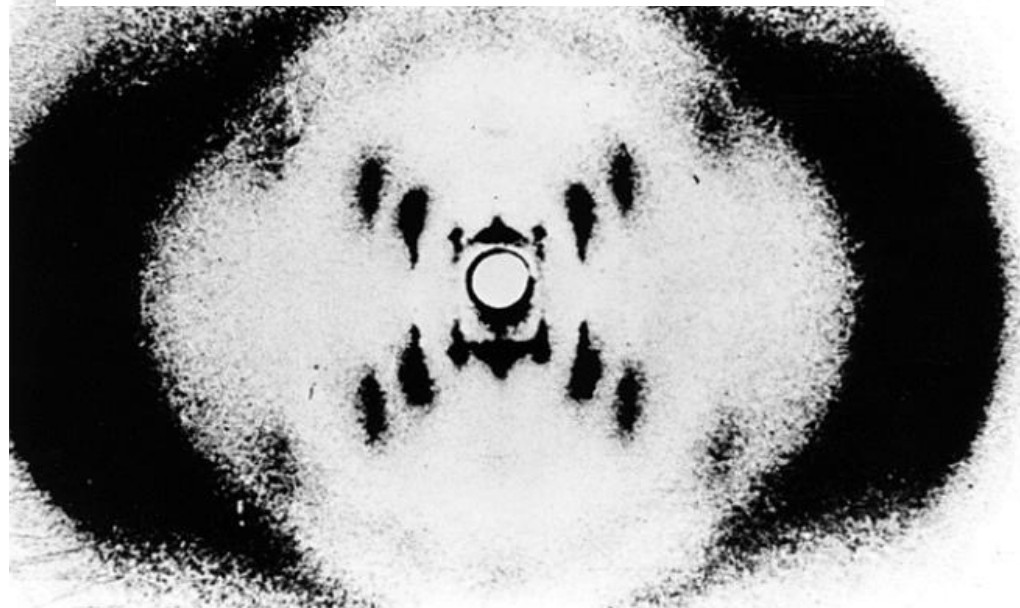

**Sunsets are so beautiful that they almost seem  
as if we were looking through the gates of Heaven.**

**Sir John Lubbock**



# Sometimes we can't see the forest for the trees (1)<sup>14</sup>

**Don't get lost in the details!**



# **Sometimes we can't see the forest for the trees (2)<sup>14</sup>**

**This is a natural state of confusion.**

**When we are learning to read**

**we cannot see the sentence for the words,  
because each word is a new experience  
which has to be understood as a part of a sentence.**

**When we are learning to dance**

**we are so preoccupied with the mechanics  
of moving our feet properly  
that we have little sense of rhythmic motion.**

**In such situations we respond to the parts**

**before we respond to the whole:**

**we see the trees before we discern the forest...**

# **Sometimes we can't see the forest for the trees (3)<sup>14</sup>**

**... everything is so new  
that we are aware only of individual experiences,  
not the pattern of these experiences...**

**But gradually a pattern begins to emerge.**

**The forest becomes perceptible.**

**J.M. McCrimmon**

**We must keep looking at the trees and through the trees.**

## **Sometimes we can't see the forest for the trees (4)<sup>14</sup>**

**[There was a] boy whose farm or cottage  
stood on such a slope,  
and who went on his travels to find some thing,  
such as the effigy and grave of some giant  
and when he was far enough from home  
he looked back and saw  
that his own farm and kitchen-garden  
shining flat on the hill-side  
like the colors and quarterings of a shield,  
were but parts of some gigantic figure,  
on which he had always lived,  
but which was too large and too close to be seen.**

**G. K. Chesterton**

**Remember the hitchhiker who had a sign that read  
“Anywhere”...  
He was already there and didn't realize it.**

# **Sometimes we can't see the forest for the trees (5)<sup>14</sup>**

**On the subject of Fractals:**

**The boundary between the set of truths  
and the set of falsities**

**is meant to suggest a randomly meandering coastline  
which,**

**no matter how closely you examine it,  
always has finer levels of structure,  
and is consequently impossible to describe exactly  
in any finite way.**

**Douglas Hofstadter**

**To travel hopefully is a better thing than to arrive.**

**Robert Louis Stevenson**

**We must study for the benefits  
that go beyond the “answers”.**

# Sometimes we can't see the forest for the trees (6)<sup>14</sup>

**Background subtraction reveals the important objects.**

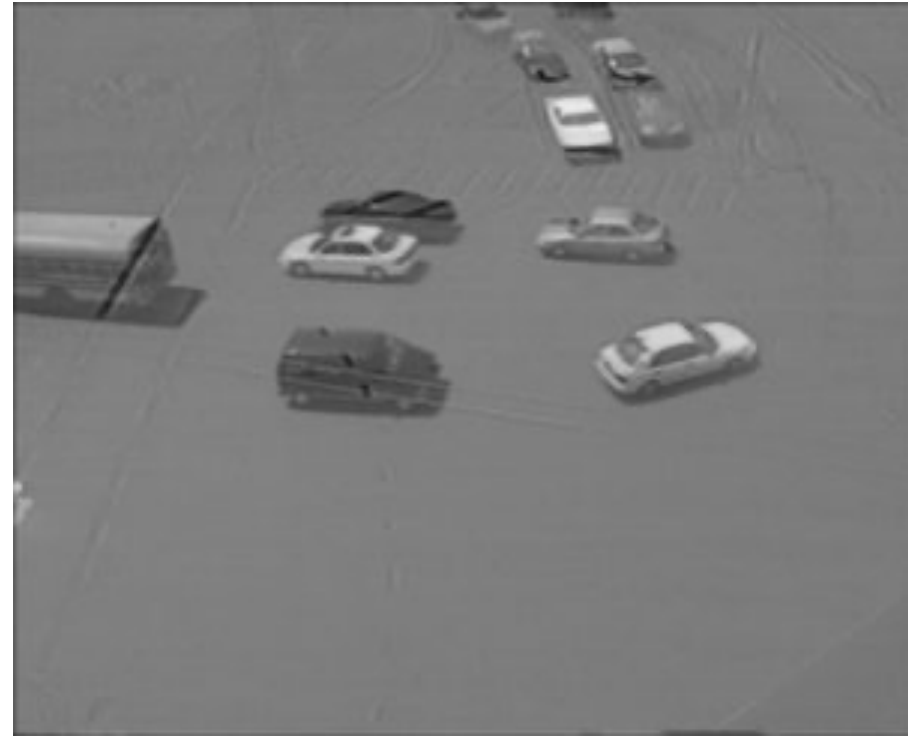

**We need to be able to see the critical core.**

## Pharisees, perceiving “sinners” as untouchables

**When the Pharisees saw this, they asked his disciples, "Why does your teacher eat with tax collectors and 'sinners'?"**

**Matthew 9:11**

**The Son of Man came eating and drinking, and they say, 'Here is a glutton and a drunkard, a friend of tax collectors and "sinners.'" ‘**

**Matthew 11:19**

**Now the tax collectors and "sinners" were all gathering around to hear him. But the Pharisees and the teachers of the law muttered, "This man welcomes sinners and eats with them."**

**Luke 15:1-2**

**On hearing this, Jesus said to them, "It is not the healthy who need a doctor, but the sick. I have not come to call the righteous, but sinners."**

**Mark 2:17**

# Outline of the Class

- Introduction
- The Perception Process
- **Pattern Structure**
- **Critical Patterns**
  - Law
  - Church
  - Family
  - God's Goodness
  - Personal
- **Developing the Pattern God Wants in Us**
- **Summary**



# Perceiving the Proper Pattern

To perceive the proper pattern of truth,

we must make sure that

- 1) we see things that are actually there, and
- 2) we don't see things that aren't there.

Remember the story of Dr. John Nash in the movie

## A Beautiful Mind

A gift for seeing patterns,

but began to see those that weren't there

Modern technology is so advanced now that we cannot really tell what is real and what is not on TV.

# Visualization is important to us!

**We all need a picture to help us understand**

- we draw sketches
- we see images in our head

**The Bible provides us many images for us to think about.**

**We especially need some way to visualize God.**

**There is a danger for people to create images,  
or idols to represent their view of God.**

**Story of the little girl who drew a picture of Jesus.**

# Visualization Helps, but is Limited



© 1999 United Feature Syndicate, Inc.

© UFS, Inc.



**Our Efforts Cannot Fully Reproduce the Pattern of Truth**

# The Hair-Curler Model

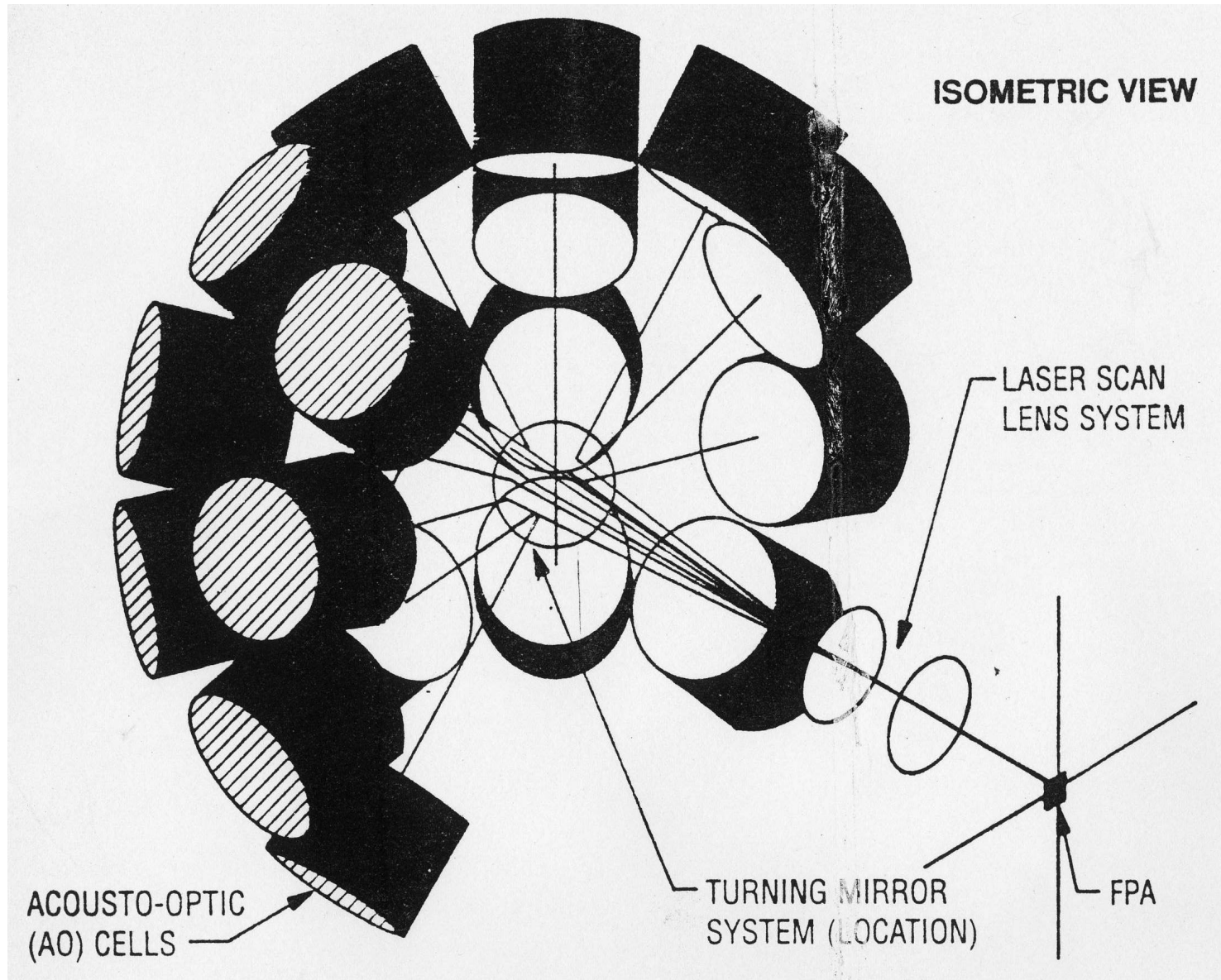

**Built a paper (then wooden) model to try to visualize it.**

# Example of imagery in the Bible

Their venom is like the venom of a snake,

like that of **a cobra that has stopped its ears,**

that will not heed the tune of the charmer,

however skillful the enchanter may be.

Break the teeth in their mouths, O God;

tear out, O LORD, the fangs of the lions!

Let them vanish like water that flows away;

when they draw the bow, let their arrows be blunted.

Like a slug melting away as it moves along...

Before your pots can feel the heat of the thorns...

the wicked will be swept away.

**Psalms 58:4-9**

# Perceiving the Proper Pattern -- Problems

**Distraction**

**Cover**

**Distortion**

**Illusion**

**Mislabeleding**

**Complexity**

**Hidden Meaning**

**Misinterpretation / Misunderstanding**

**We will look at each of these  
and then come back to them in our study**

# Perceiving the Proper Pattern in a Map

A map contains very important information about how to get where we want to go.

We will use this to represent Truth at other levels.



# Perceiving the Proper Pattern -- Distraction

4

Sometimes something else distracts us and we cannot focus on the Truth.

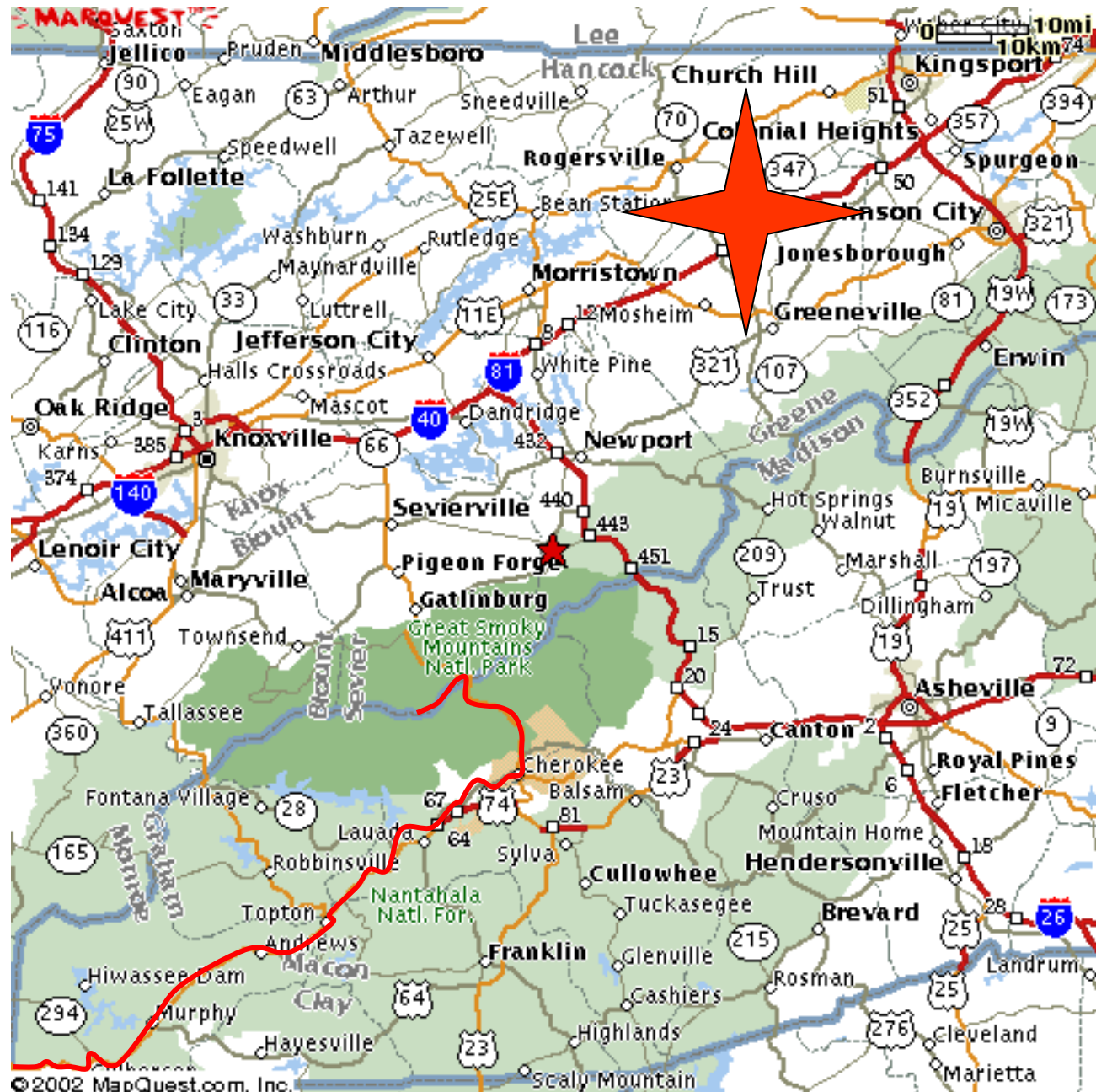



# Perceiving the Proper Pattern -- Covered

Sometimes portions of Truth are covered at strategic locations in such a way that we cannot perceive the meaning.

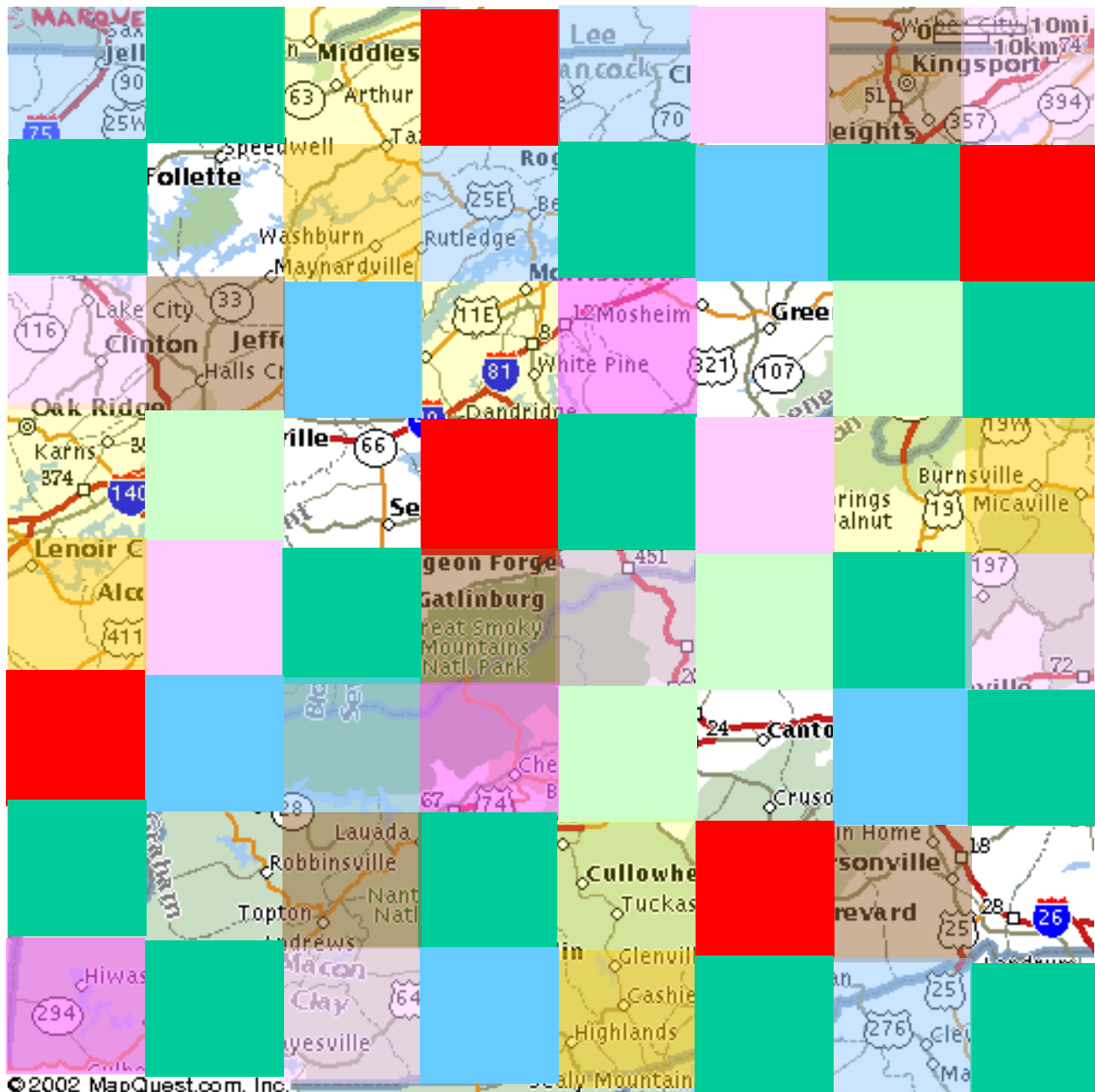

# Perceiving the Proper Pattern -- Mislabeled

Sometimes the labels are rearranged to make unimportant things look important, and vice versa. Think if this happened in a store.



# Perceiving the Proper Pattern -- Distorted

**Sometimes there is something that distorts the Truth so that we cannot read it no matter how we squint. This distortion can arise from internal (self) or external sources.**



# Perceiving the Proper Pattern -- Illusion

**Sometimes there is an illusion that causes us to think that something else is present or happening (motion, etc).**

**This distortion can arise from internal (self) or external sources**

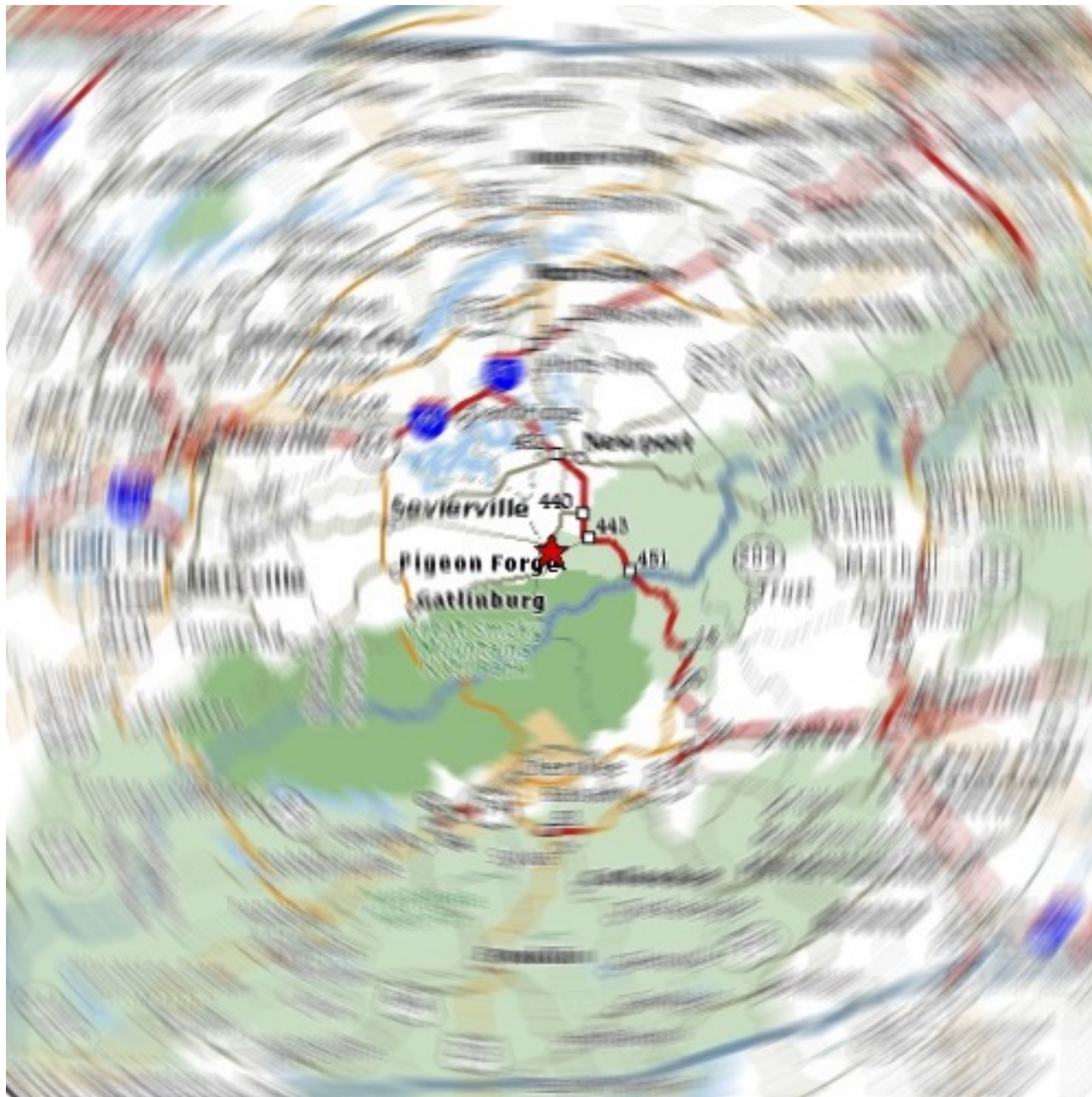

# Perceiving the Proper Pattern -- Complexity

Sometimes there is added information that may not be important to the actual path we are trying to take (for instance, mountains, rivers, contours)

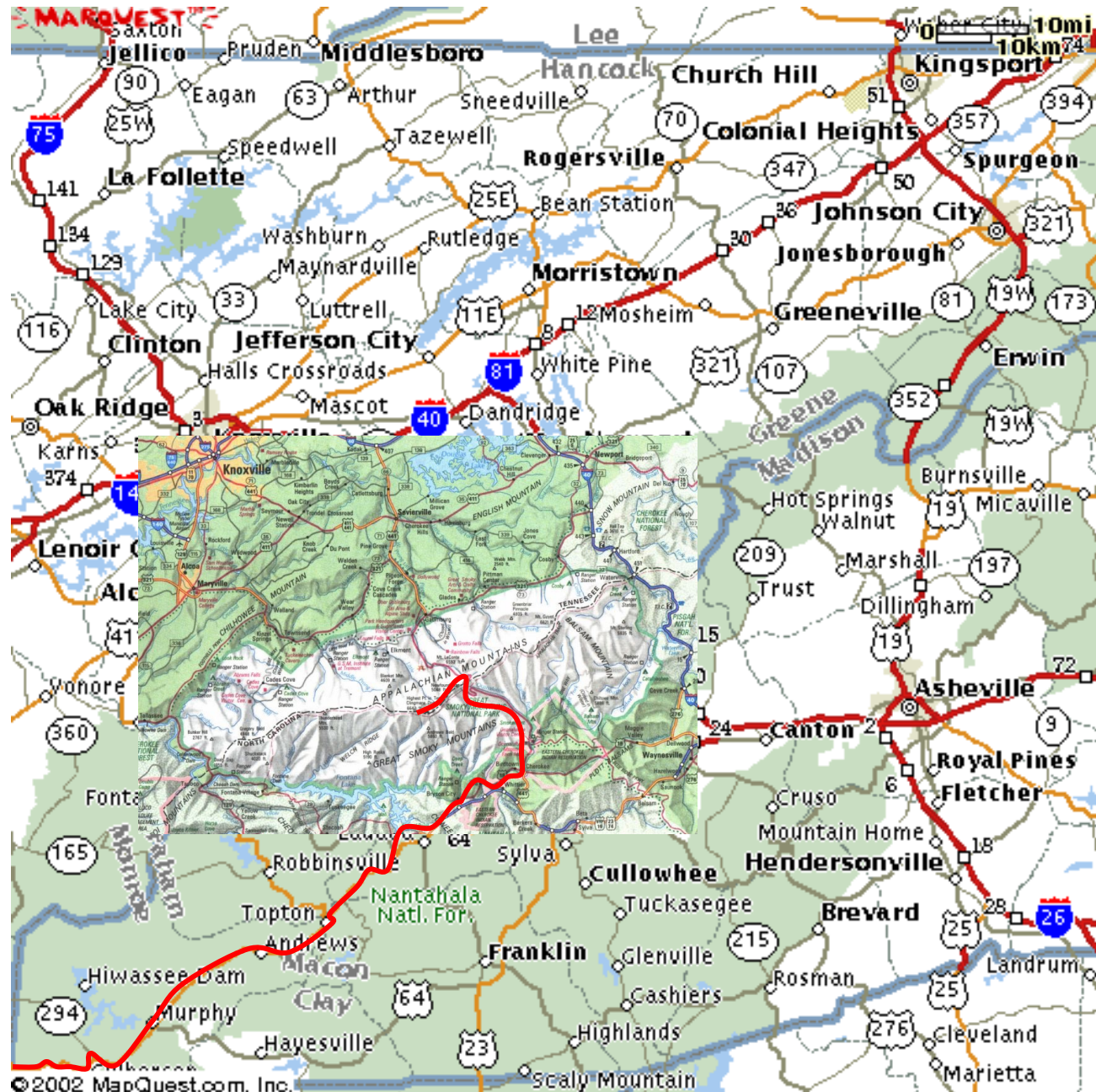

# Perceiving the Proper Pattern – More Complexity <sup>4</sup>

Sometimes there is added information that may not be important to the actual path we are trying to take (perhaps even another dimension that looks awesome but adds no real value)



# Perceiving the Proper Pattern – Hidden Information<sup>4</sup>



**Phenomena perceived to be magical  
are always the outcome of complex patterns  
of non-magical activities  
taking place at a level below perception.**

**Doug Hofstadter**

**Once the pattern “matches”, we have an “Aha” experience.**



# The Pattern of God's Plan (1)

God has given us the pattern that he wants us to follow.

It is so important to determine what is the basis,  
or the foundation of our spiritual life.

We need to think about the core of our belief.

This begins with the Jewish heritage  
that we are all so familiar with.

Normally, our first thought would be  
about how we are rooted in the ten commandments  
that God delivered to His people through Moses.

# The Ten Commandments (Deuteronomy 5:6-22) 4

{6} "I am the LORD your God, who brought you out of Egypt, out of the land of slavery.

1 {7} "You shall have no other gods before me.

2 {8} "You shall not make for yourself an idol

in the form of anything in heaven above or on the earth beneath or in the waters below. {9} You shall not bow down to them or worship them; for I, the LORD your God, am a jealous God, punishing the children for the sin of the fathers to the third and fourth generation of those who hate me, {10} but showing love to a thousand generations of those who love me and keep my commandments.

3 {11} "You shall not misuse the name of the LORD your God,

for the LORD will not hold anyone guiltless who misuses his name.

4 {12} "Observe the Sabbath day by keeping it holy

as the LORD your God has commanded you. {13} Six days you shall labor and do all your work, {14} but the seventh day is a Sabbath to the LORD your God. On it you shall not do any work...

5 {16} "Honor your father and your mother

as the LORD your God has commanded you, so that you may live long and that it may go well with you in the land the LORD your God is giving you.

6 {17} "You shall not murder.

7 {18} "You shall not commit adultery.

8 {19} "You shall not steal.

9 {20} "You shall not give false testimony against your neighbor.

10 {21} "You shall not covet

your neighbor's wife. You shall not set your desire on your neighbor's house or land, his manservant or maidservant, his ox or donkey, or anything that belongs to your neighbor."

{22} **These are the commandments the LORD proclaimed in a loud voice to your whole assembly there on the mountain from out of the fire, the cloud and the deep darkness; and he added nothing more. Then he wrote them on two stone tablets and gave them to me.**

**Was God promoting Rules  
or a Relationship?**

# Building the Pattern of Truth

the Ten Commandments

# The Pattern of God's Plan (2)

The Israelites obviously revered these statutes, and thought of them as the ultimate set of rules for their behavior.

All kinds of people have based their lives on this list as well, whether they were Jews or not.

But God gave many other commands His chosen people, that were not really given that much attention.

The 10 commandments were used as a standard when Jesus questioned them about their spirituality.

# The Pattern of God's Plan (3)

**God wants justice, but within the scope of His Grace.**

Another rule that many of the Jews,  
and many people today,  
consider as representative of  
the will of the God of the Old Testament  
the Pharisees saw as a critical addition concerns justice:  
that of an **eye for an eye and a tooth for a tooth**.

But people use that to exact revenge  
on those who have slighted them,  
and this was not God's intent.

This idea is referred to several times in the Old Testament.

# An Eye for an Eye

**But if there is serious injury, you are to take life for life, eye for eye, tooth for tooth, hand for hand, foot for foot, burn for burn, wound for wound, bruise for bruise.**

**Exodus 21:23-25**

**If anyone injures his neighbor, whatever he has done must be done to him:**

**fracture for fracture, eye for eye, tooth for tooth.**

**As he has injured the other, so he is to be injured.**

**Leviticus 24:19-20**

**Show no pity: life for life, eye for eye, tooth for tooth, hand for hand, foot for foot.**

**Deuteronomy 19:21**

**life for life, eye for eye, tooth for tooth, hand for hand, foot for foot, burn for burn, wound for wound, bruise for bruise, fracture for fracture**

# Building the Pattern of Truth

an eye for an eye...

the Ten Commandments

# The Pattern of God's Plan (4)

**God wanted man to see what was most important.**

These two basic principles, or groups of principles, can be seen as the driving force behind the Jewish interpretation of their religion.

There was much more attention paid to rules than principles, and there is a huge difference between them.

One scripture that was a highlight and sacred to many is found a few verses after the 10 commandments, and it is referred to as the

**Shema**

from the first word "hear".



**Hear, O Israel: The LORD our God, the LORD is one.**

**Love the LORD your God with all your heart and  
with all your soul and  
with all your strength.**

**These commandments that I give you today  
are to be upon your hearts.**

**Deuteronomy 6:4-6**

**God says:**

**“Love me, love my creation.”**

**But the Jewish people didn't get it.**

# Building the Pattern of Truth

the Shema

an eye for an eye...

the Ten Commandments

# The Pattern of God's Plan (5)

God want Love to be the cornerstone of the pattern.

The Shema speaks of loving God with every fiber of our being.

Notice that there was no mention of **love** in the ten commandments, which seem rather stern or austere.

A careful examination of the Old Testament shows that God wants people to love each other, but this is not really paid attention to.

In particular, He makes it very clear that there is a great contrast between Good and Evil, and that there is only one choice for us.

# Hate Evil, Love Good

Turn from evil and **do good**; seek peace and pursue it.

**Psalms 34:14**

Turn from evil and **do good**; then you will dwell in the land forever.

**Psalms 37:27**

You love evil rather than good, falsehood rather than speaking the truth.

**Psalms 52:3**

**Seek good, not evil**, that you may live.

Then the LORD God Almighty will be with you, just as you say he is.

**Hate evil, love good...**

**Amos 5:14-15**

Love must be sincere. **Hate what is evil; cling to what is good.**

**Romans 12:9**

He didn't come to give us formulas.

He came to give us a new mindset –  
one that has a turnaround mentality.

In fact, the word repent means to turn around.

Laurie Beth Jones

# Self-Delusion



**We must be very careful to avoid deluding ourselves.**



# Not Seeing the Proper Truth – Color Blindness

Seeing what is there based on improperly operated detectors

Normal vision should read the number 29.

Red-green deficiencies should read the number 70.

Total color blindness should not read any numeral

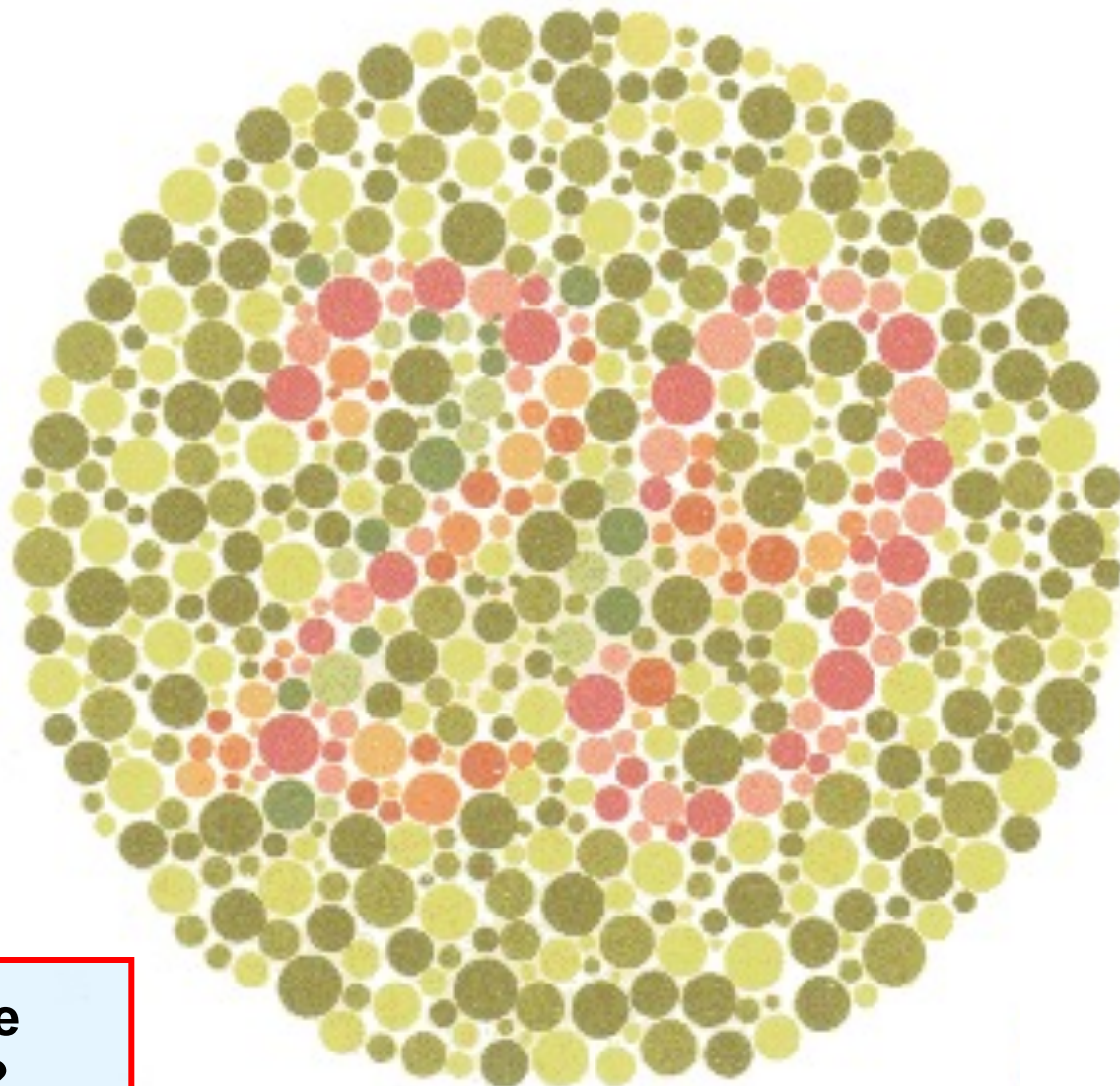

Does anyone here have trouble seeing colors?

# Not Seeing the Proper Truth – Color Blindness

How can someone with color blindness drive?

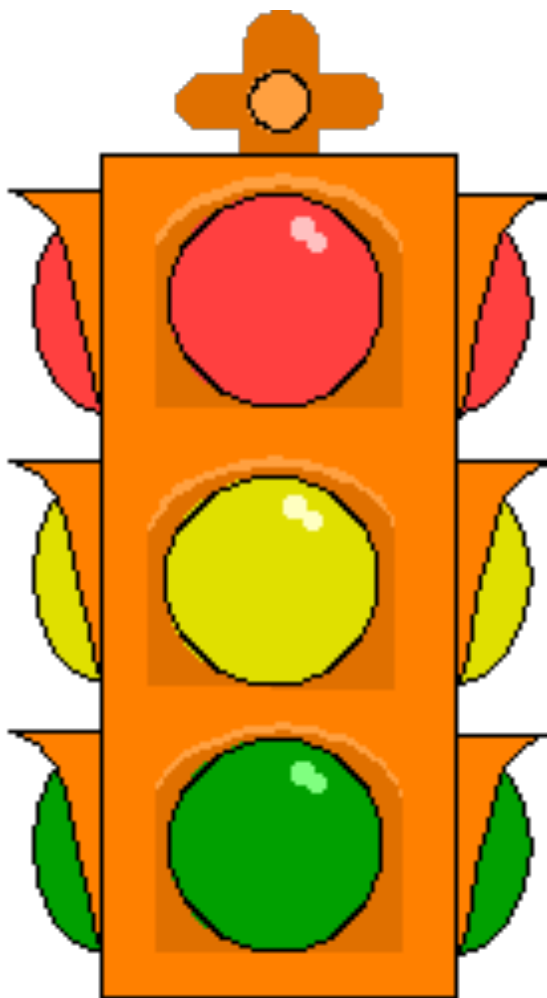

**They must switch to a more dependable pattern:  
standardized positioning of colors in traffic lights**



# Is the problem the record or the record player?

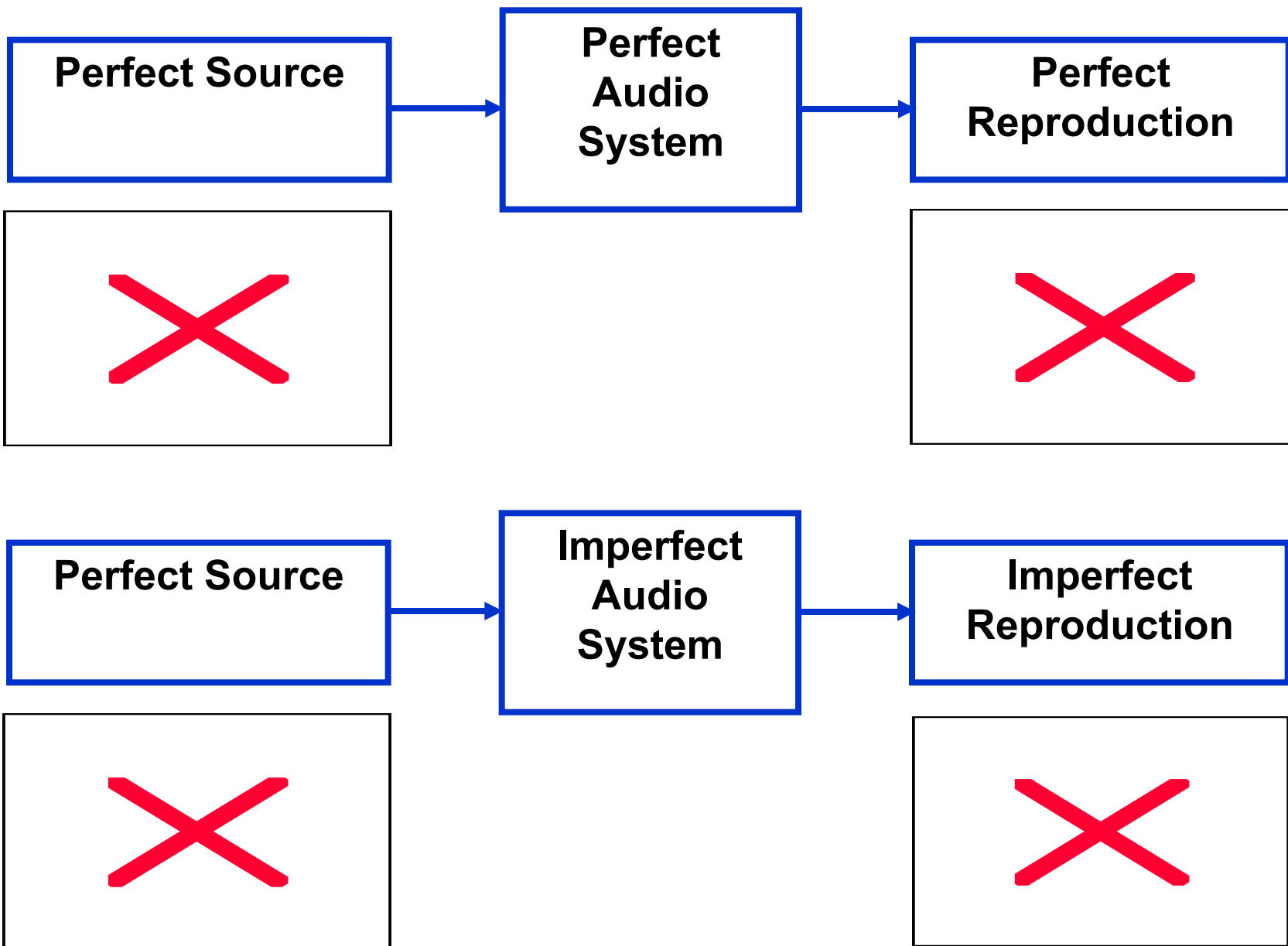

# Seeing improper Truth -- Illusion of Movement

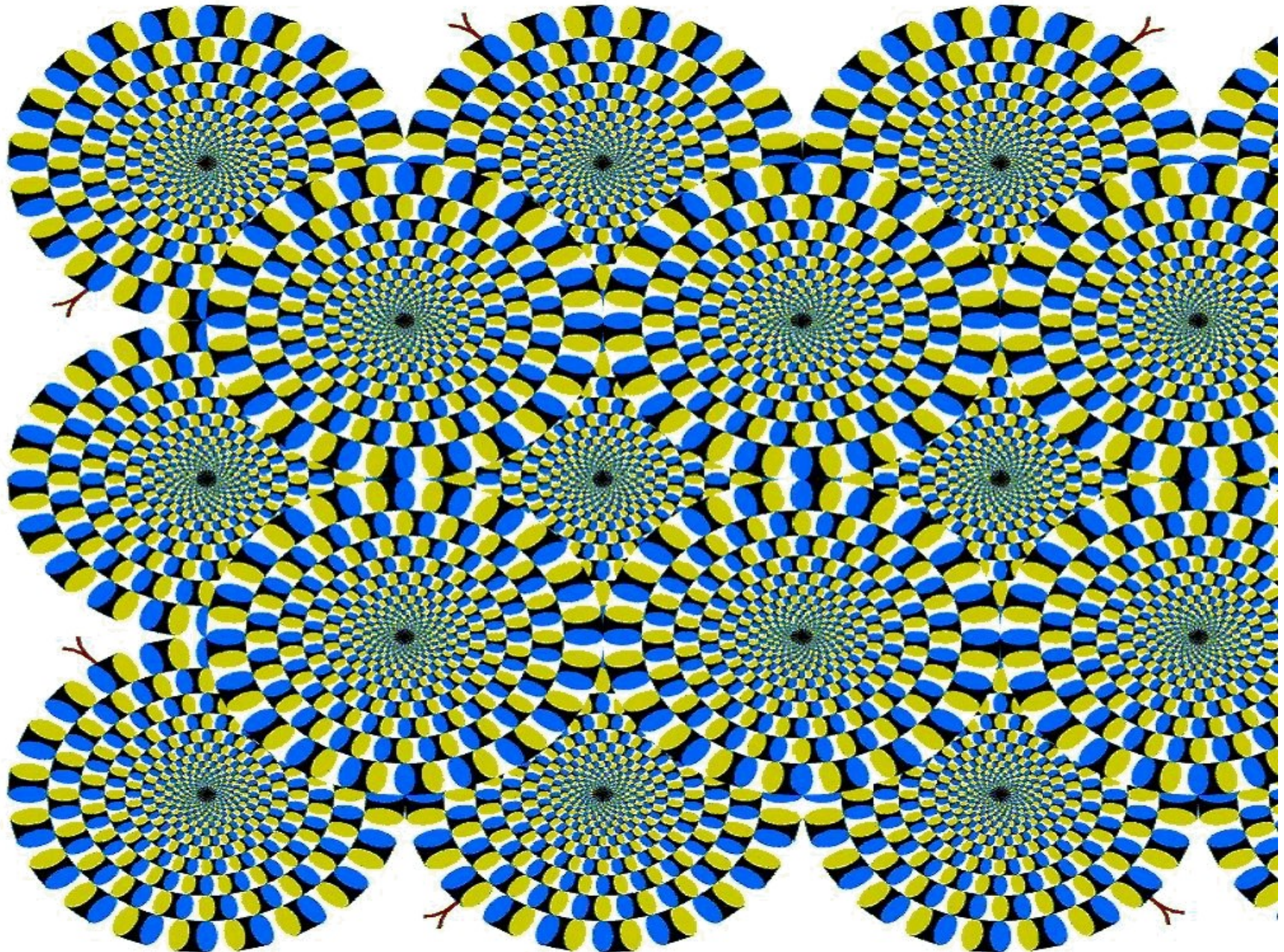

# Filling in the Gaps

**We humans like to label things,  
to wrap our minds around a concept,  
to define and package it;  
in essence to limit it  
so that the concept finds harmony  
within our human definition of logic.**

**Gerald Schroeder, The Hidden Face of God**

**This applies to visual, acoustic, and other sensory perceptions.**

**We cannot directly absorb the infinity of God's Truth. He gives us the critical structure, and we have to fill it in according to His guidelines.**



**Claude Monet was a renowned impressionistic painter**

**There are logical relationships for which the brain hunts,  
and when they are not there  
the brain does the best it can with the facts it has.**

**Gerald Schroeder**

# Pointillism

**Georges-Pierre Seurat  
was involved in a slightly  
different technique**

**Newspaper half-toning  
produces sufficient  
resolution for pictures.**

**The brain always wants to fill in  
the dots, even when dots are all  
there are. Gerald  
Schroeder**



# Fractals are used to generate the illusion of reality<sup>8</sup>

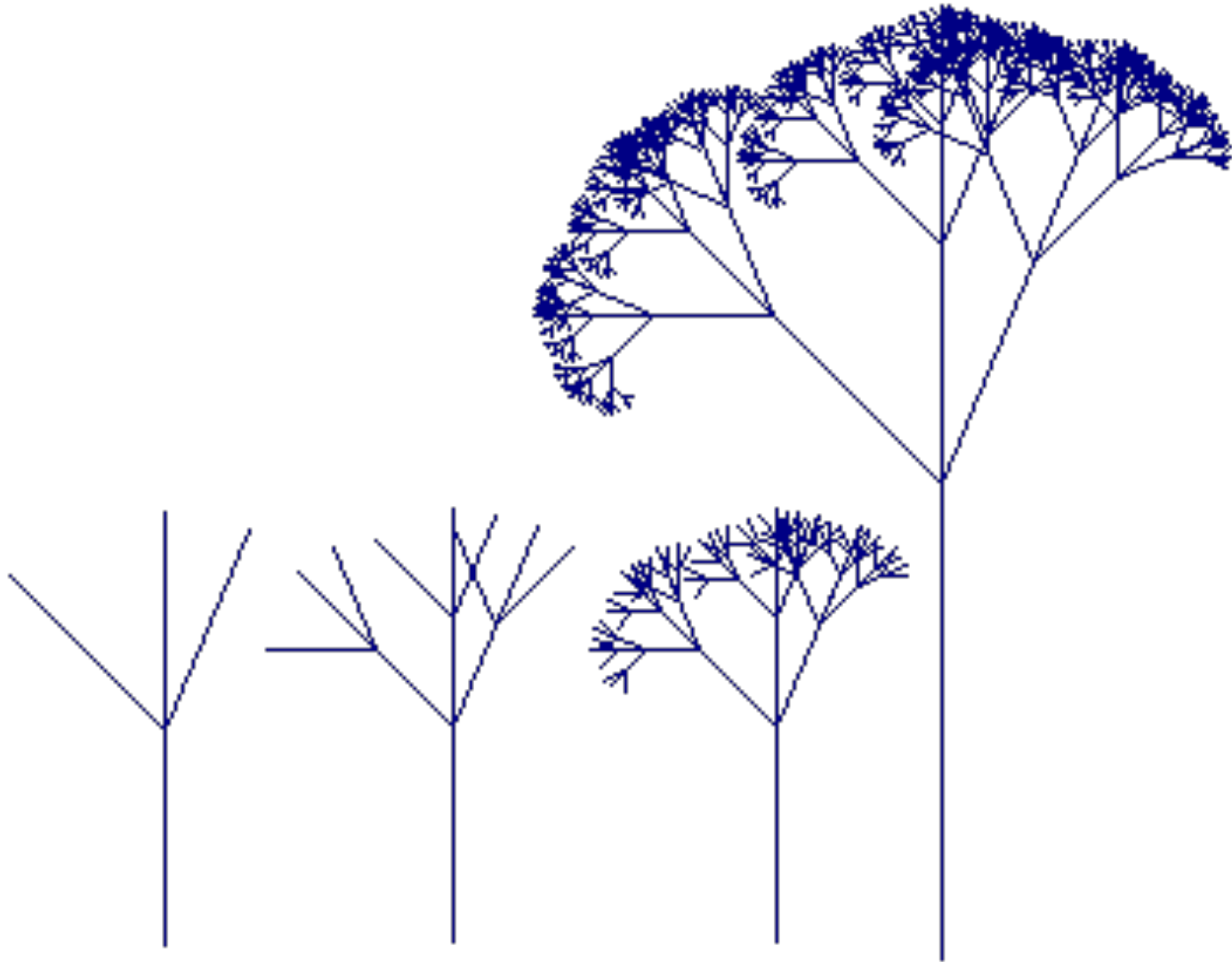

**Scenes can be generated without all of the cost and digital memory storage needed to reproduce each scene individually.**

# How do we visualize a higher dimensional object?<sup>8</sup>

We can look at its shadow



See three different projections of this object  
A snapshot cannot describe this fully

# Pledge of the Allegiance: Kindergarten

I pledge allegiance to the Flag  
of the United States of America,  
and to the Republic for which it stands:  
one Nation under God, indivisible,  
With Liberty and Justice for all.

Individually mic'd children produce gibberish, but the group as a whole gives an understandable performance.



**How do we recognize people's faces?**

**How do we connect people's faces with names?**

**We can think of the process of recognition as putting puzzle pieces together until we “see” the subject.**



**We have to be able to understand the pattern, how all of the pieces of the puzzle work together. We don't have to understand every piece, but we must be able to recognize the whole picture even though some pieces are missing.**

**It gives you a great aha! experience when you finally get the message.**

# Using an Identi-kit to help Recognition

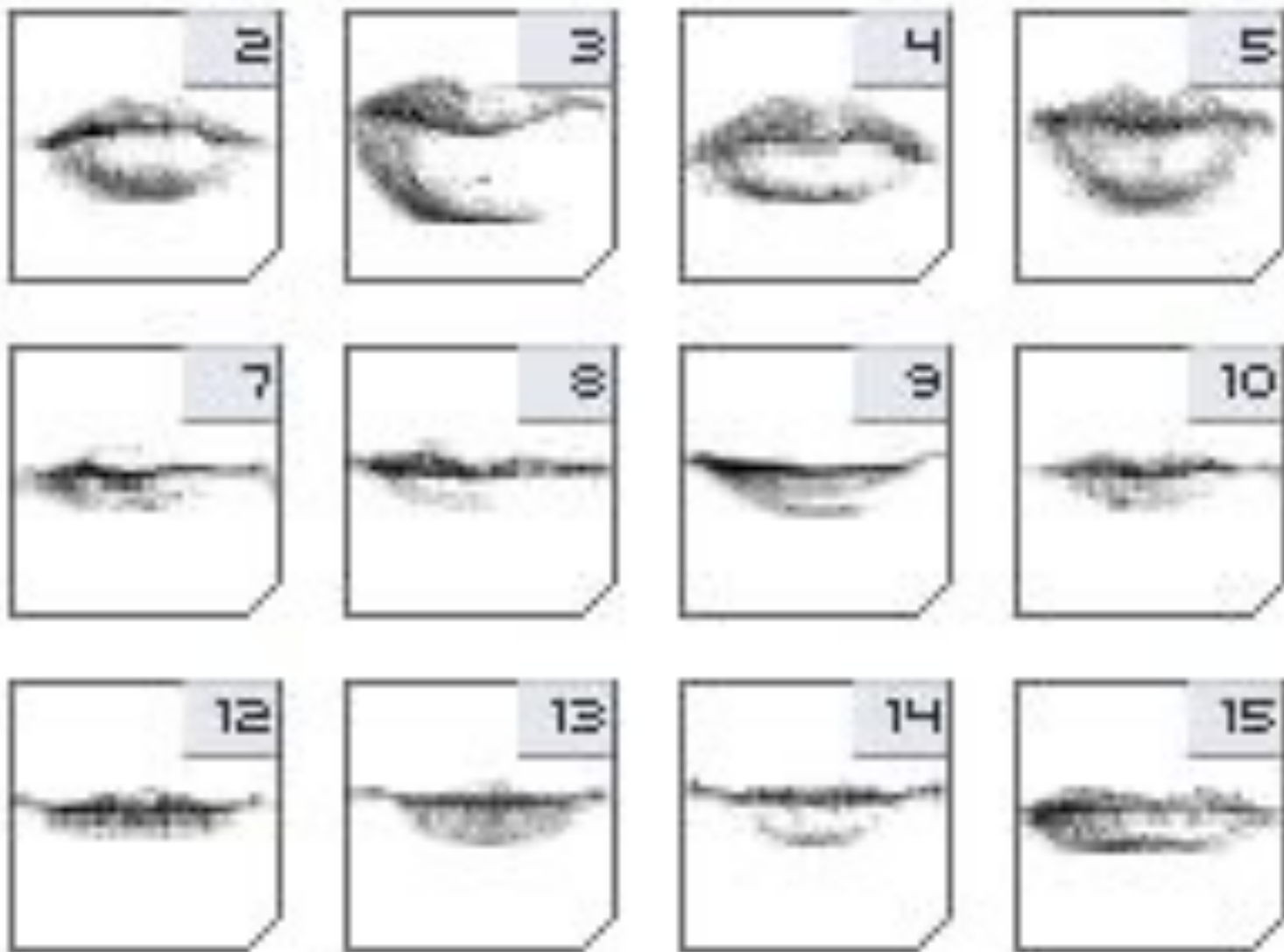

**The combination of many features creates our “look”**

# How do we recognized an aging face?

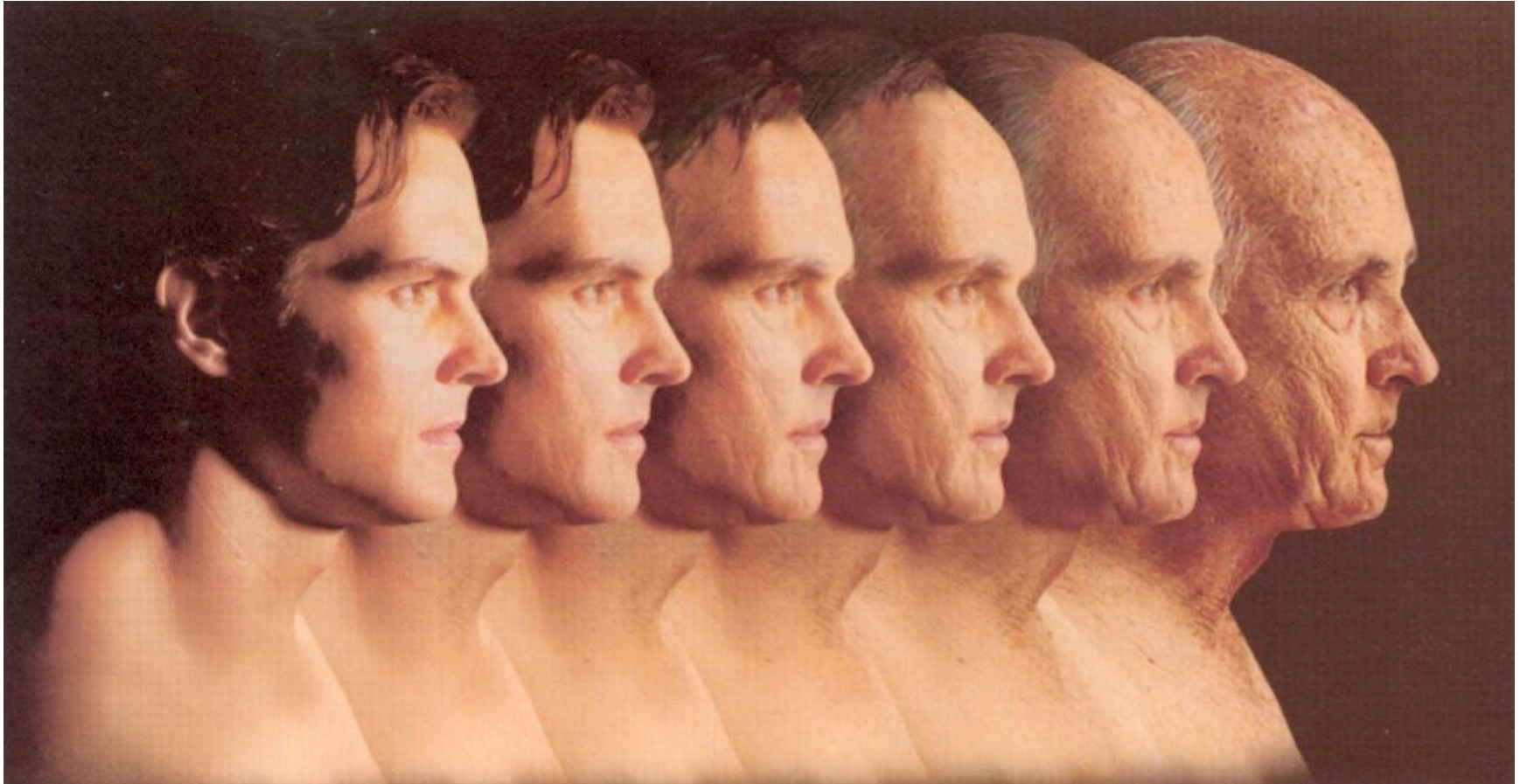

**The basic characteristics are the same**

# How do we recognize the face of Christ?

**For God, who said,**

**"Let light shine out of darkness,"**

**made his light shine in our hearts**

**to give us the light of the knowledge**

**of the glory of God**

**in the face of Christ.**

**2 Corinthians 4:6**

**We must "see" him in our hearts!**

# How do we recognize the face of God?

**If anyone says, "I love God,"  
yet hates his brother, he is a liar.**

**For anyone  
who does not love his brother,  
whom he has seen,  
cannot love God,  
whom he has not seen.**

**And he has given us this command:  
Whoever loves God must also love his brother.**

**1 John 4:20-21**

**We must "see" him in other people!**

# How do we recognize the face of other Christians? <sup>1</sup>

**"A new command I give you:**

**Love one another.**

**As I have loved you,**

**so you must love one another.**

**By this all men will know that you are my disciples,  
if you love one another."**

**John 13:34-35**

**They will know we are Christians by our love.**

**Should we not have the face of God?**

**In reality, they know we are not truly Christ-like  
Because we are always fighting and disputing**

# The Great Stone Face (New Hampshire)



**Nathaniel Hawthorne's story of a boy who becomes transformed into the image of the Great Stone Face.**



**We must be careful not to see the wrong face**

11



**Or to see one that isn't really there**

Religious pareidolia is pareidolia (the perception of a pattern where none intended) involving religious themes, especially the faces of religious figures. Many instances that are reported involve images of Jesus or other Christian figures seen in food, but it has an equivalent in the Muslim world where structures in food and other natural objects are perceived as religious text in Arabic, particularly the word Allah or verses from the Qur'an.



Seeing Mother  
Theresa in a  
honey bun  
(Nashville, TN)



# Some Pareidolia get Help from People

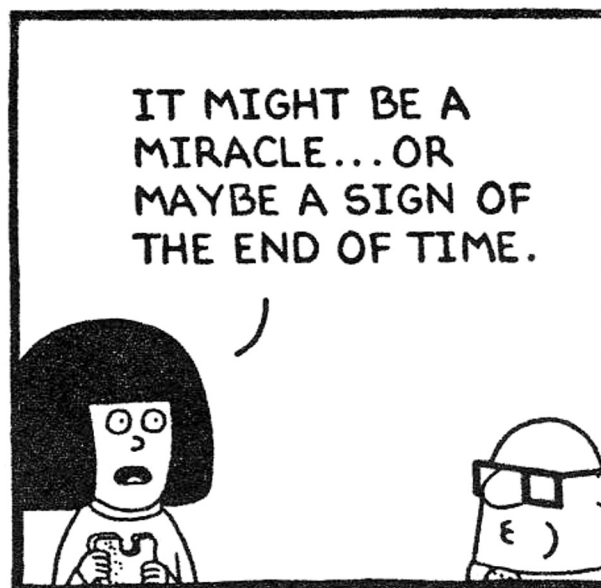

2/25/02 © 2002 United Feature Syndicate, Inc.

# The Canals of Mars



People want things so bad that they see them. We must not let our perceptions be driven by our desires.

Percival Lowell “saw” canals and thought they signified life.

# Present-day “Features” on Mars

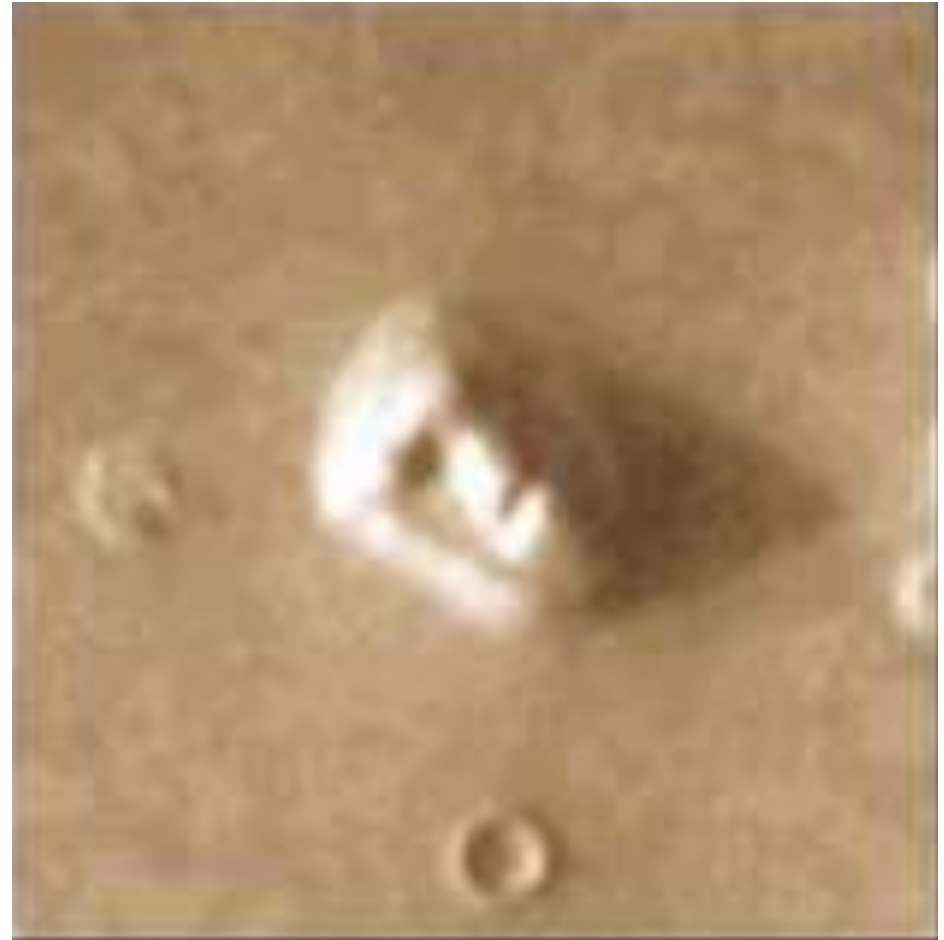

**“Happy Face” Crater**

**Other Face Structure**



**At what age do we realize that this is a cartoon character and not a real being?**

# How do we recognize the face of Truth?

**We must recognize the face of Christ.**

**We must recognize the face of God.**

**We must recognize the face of our neighbor/brother.**

**We must recognize the faces of other Christians.**

# How can we look at such Truth directly?

Think about how natural it is to look into people's eyes  
(animals know to do it, too)

Consider looking into the eye of the innocent lamb  
about to be sacrificed.

About an hour later another asserted, "Certainly this fellow  
was with him, for he is a Galilean."

Peter replied, "Man, I don't know what you're talking about!"

Just as he was speaking, the rooster crowed.

**The Lord turned and looked straight at Peter.**

Then Peter remembered the word the Lord had spoken to  
him: "Before the rooster crows today, you will disown me  
three times." And he went outside and wept bitterly.

**Luke 22:59-62**



# We must keep our eyes fixed on that Truth

**Let us fix our eyes on Jesus,**  
the author and perfecter of our faith,  
who for the joy set before him endured the cross,  
scorning its shame,  
and sat down at the right hand of the throne of God.

**Hebrews 12:2**

**Coach: Keep your eye on the ball!**



**We must work hard  
to read  
the face of God!**

**How do we read so much information from a face?**

# Peek-a-boo!



**Do we play games with the Face of God?  
Or with our own (Adam and Eve with fig leaves)?**

# Do we try to change our face?

**Do we put on makeup to try to hide our real nature?**

**We must bare our souls and our faces to God.**

**Women spend thousands of dollars  
to “fix” perceived imperfections in their faces  
(and bodies),  
but they need to fix their face to be  
one that people trust  
and feel they can tell their troubles to.  
This is the lead in helping people.**

# How do we recognize each other in heaven?

12

People will know you at different points in your life.

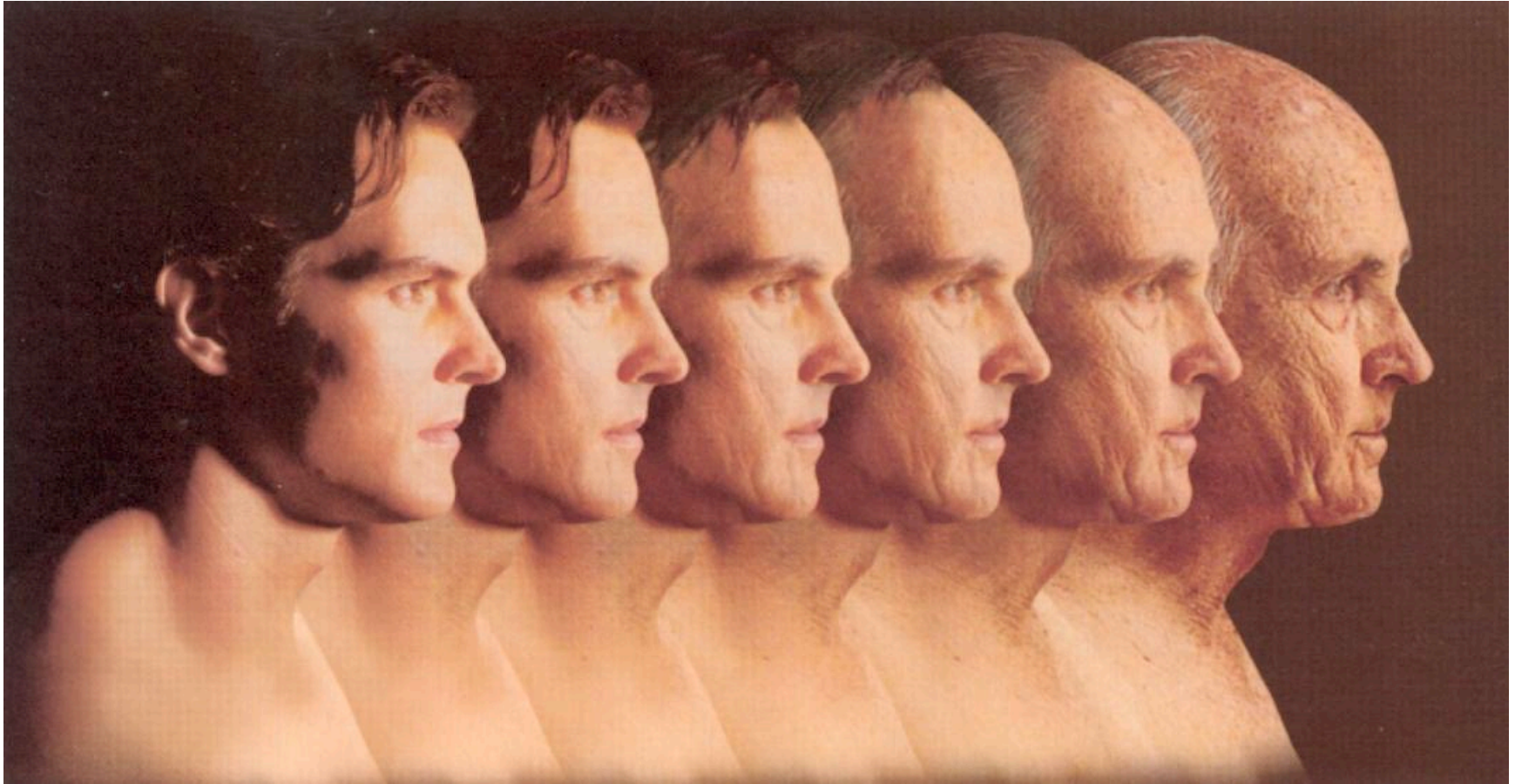

Looks won't matter (thank goodness), nor the passage of time.  
We will know from the heart,  
just as we will know God and He will know us.

# **We must open our eyes**

**Consider a person blind from birth.**

**I remember seeing a blind girl at Walt Disney World.**

**She didn't even open her eyelids.**

**Her visual pattern was fixed and unchangeable.**

**Think about when Christ healed someone  
blind from birth (John 9).**

**Imagine what it would feel like to suddenly see!**

**You would have some sense of objects by feel,**

**But you would have no expectation of color!**

**We have a similar transition when we “see” the order of  
the true magnitude of God's Glory.**

## **...or have them opened by God**

**They came to Bethsaida, and some people brought a blind man and begged Jesus to touch him.**

**He took the blind man by the hand and led him outside the village. When he had spit on the man's eyes and put his hands on him, Jesus asked, "Do you see anything?"**

**He looked up and said, "I see people; they look like trees walking around."**

**Once more Jesus put his hands on the man's eyes. Then his eyes were opened, his sight was restored, and he saw everything clearly.**

**Mark 8:22-25**

**There is a difference between having our eyes open and truly being able to perceive.**

# **We must open our eyes**

**Jesus accused the Pharisees of being blind**

**Woe to you, blind guides! ...**

**You blind fools!**

**You blind men!**

**You blind guides!**

**Blind Pharisee!**

**Matthew 23:6, 17, 19, 24, 26**

**Be cautious about our confidence in perception**

**Jesus said, "For judgment I have come into this world,  
so that the blind will see  
and those who see will become blind."**

**John 9:9**



# **We must feel the power of resonance when we see the Truth**

**If we don't feel the emotional power  
of seeing the Truth,  
there is something seriously wrong with us.**

**Is it too late?**

**Have we been seared with a hot iron (1 Timothy 4:2)?**

**We can still change our pattern to align with God's!**

**We need to continually renew our perception,  
Like we adjusted our the TV antenna for best reception!**

# Will we recognize each other in heaven?

## Thoughts...

**David saying that he would go be with his dead son;**

**2 Sam 12:23**

**Story of Abraham, Lazarus, and the rich man; Luke 16**

**We are described as “souls” (individual);**

**1 Peter 2:25, Rev 20:4**

# Perceptions – Peter getting out of jail

**It was about this time that King Herod arrested some who belonged to the church, intending to persecute them.**

**He had James, the brother of John, put to death with the sword.**

**When he saw that this pleased the Jews, he proceeded to seize Peter also...**

**After arresting him, he put him in prison, handing him over to be guarded by four squads of four soldiers each.**

**Herod intended to bring him out for public trial after the Passover.**

**So Peter was kept in prison, but the church was earnestly praying to God for him.**

**Goal?**

**Acts 12:1-5**

# Perceptions – Peter getting out of jail

The **night before** Herod was to bring him to trial, Peter was sleeping between two soldiers, bound with two chains, and sentries stood guard at the entrance.

**Suddenly** an angel of the Lord appeared and a light shone in the cell.

**He struck Peter on the side** and woke him up.

**"Quick, get up!"** he said, and the chains fell off Peter's wrists.

Then the angel said to him, "Put on your clothes and sandals."

And Peter did so. "Wrap your cloak around you and follow me," the angel told him.

Peter followed him out of the prison, but he had no idea that what the angel was doing was really happening; **he thought he was seeing a vision.**

They passed the first and second guards and came to the iron gate leading to the city.

It **opened** for them **by itself**, and they went through it.

When they had walked the length of one street, **suddenly** the angel left him.

**Acts 12:9-10**

# Perceptions – Peter getting out of jail

Then Peter came to himself and said,

**"Now I know without a doubt** that the Lord sent his angel and rescued me from Herod's clutches and from everything the Jewish people were **anticipating.**"

**Suddenly he is alone and a hunted fugitive**

When this had **dawned** on him,

he went to the house of Mary the mother of John,  
also called Mark,

where many people had gathered and were praying.

**Acts 12:11-12**

**Peter thought the gate opened by itself,**

**but ultimately realized that the power of God was behind it.**

# Perceptions – Peter getting out of jail

Peter knocked at the outer entrance, and **They were hiding**  
a servant girl named Rhoda came to answer the door.

When she recognized Peter's voice, she was so overjoyed  
she ran back without opening it and exclaimed,  
"Peter is at the door!"

"You're **out of your mind**," they told her.

When she kept insisting that it was so, they said,  
"**It must be his angel.**"

But Peter kept on knocking, **He was exposed!**  
and when they opened the door and saw him,  
they were **astonished**.

Acts 12:13-16

**The church assumed that it had to be Peter's angel.**

# Perceptions – Peter getting out of jail

**Think of the faith of this group of Christians.**

**They had assembled to pray Peter our of jail –  
but couldn't believe it when it happened!**



# Sometimes we can't see the forest for the trees (1)<sup>14</sup>

**Don't get lost in the details!**

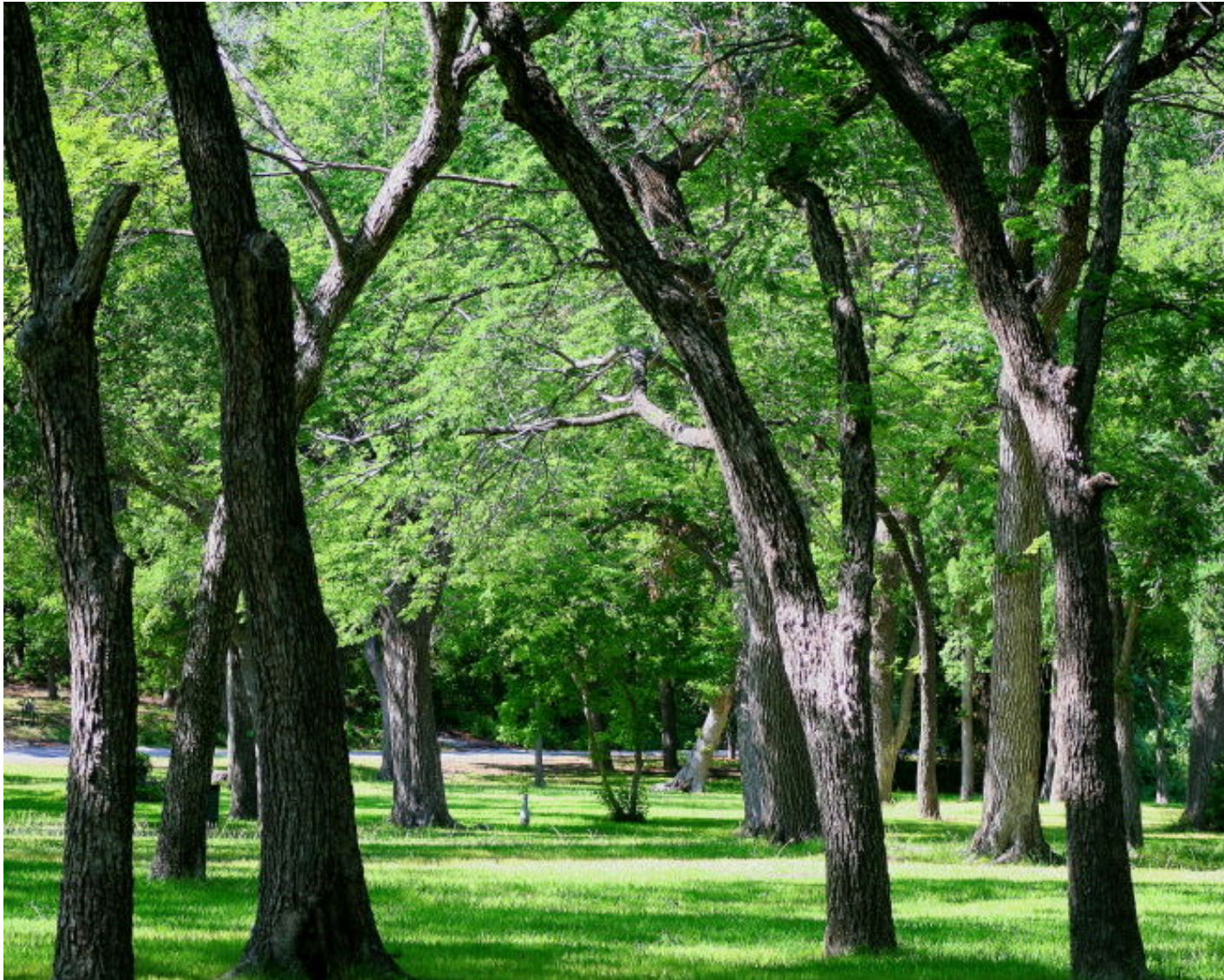

# **Sometimes we can't see the forest for the trees (2)<sup>14</sup>**

**This is a natural state of confusion.**

**When we are learning to read**

**we cannot see the sentence for the words,  
because each word is a new experience  
which has to be understood as a part of a sentence.**

**When we are learning to dance**

**we are so preoccupied with the mechanics  
of moving our feet properly  
that we have little sense of rhythmic motion.**

**In such situations we respond to the parts**

**before we respond to the whole:**

**we see the trees before we discern the forest...**

# Sometimes we can't see the forest for the trees (3)<sup>14</sup>

**... everything is so new  
that we are aware only of individual experiences,  
not the pattern of these experiences...**

**But gradually a pattern begins to emerge.**

**The forest becomes perceptible.**

**J.M. McCrimmon**

**We must keep looking at the trees and through the trees.**

## **Sometimes we can't see the forest for the trees (4)<sup>14</sup>**

**[There was a] boy whose farm or cottage  
stood on such a slope,  
and who went on his travels to find some thing,  
such as the effigy and grave of some giant  
and when he was far enough from home  
he looked back and saw  
that his own farm and kitchen-garden  
shining flat on the hill-side  
like the colors and quarterings of a shield,  
were but parts of some gigantic figure,  
on which he had always lived,  
but which was too large and too close to be seen.**

**G. K. Chesterton**

**Remember the hitchhiker who had a sign that read  
“Anywhere”...  
He was already there and didn't realize it.**

# **Sometimes we can't see the forest for the trees (5)<sup>14</sup>**

**On the subject of Fractals:**

**The boundary between the set of truths  
and the set of falsities**

**is meant to suggest a randomly meandering coastline  
which,**

**no matter how closely you examine it,  
always has finer levels of structure,  
and is consequently impossible to describe exactly  
in any finite way.**

**Douglas Hofstadter**

**To travel hopefully is a better thing than to arrive.**

**Robert Louis Stevenson**

**We must study for the benefits  
that go beyond the “answers”.**

# Sometimes we can't see the forest for the trees (6)<sup>14</sup>

Background subtraction reveals the important objects.

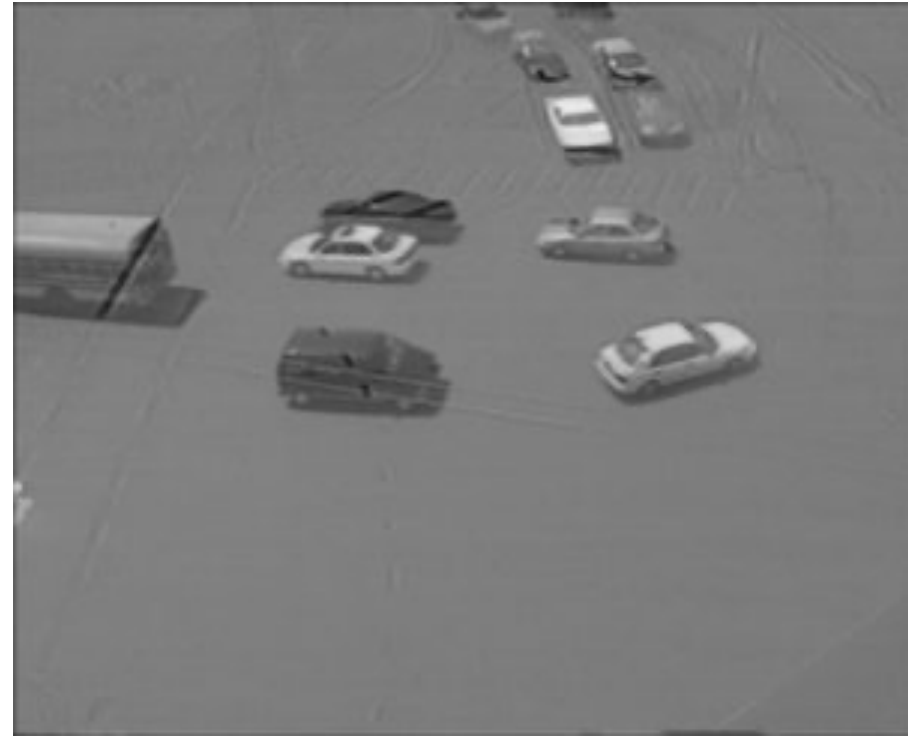

We need to be able to see the critical core.

## Pharisees, perceiving “sinners” as untouchables

**When the Pharisees saw this, they asked his disciples, "Why does your teacher eat with tax collectors and 'sinners'?"**

**Matthew 9:11**

**The Son of Man came eating and drinking, and they say, 'Here is a glutton and a drunkard, a friend of tax collectors and "sinners.'" ‘**

**Matthew 11:19**

**Now the tax collectors and "sinners" were all gathering around to hear him. But the Pharisees and the teachers of the law muttered, "This man welcomes sinners and eats with them."**

**Luke 15:1-2**

**On hearing this, Jesus said to them, "It is not the healthy who need a doctor, but the sick. I have not come to call the righteous, but sinners."**

**Mark 2:17**

**Good Movies have a great theme that many times is hidden by the stars, comedy, language, or sexuality.**

**Twins**

**Bedazzled**

**Groundhog Day**

**Maid to Order**

**You have to peel the skin off of the onion.  
You have to look very closely to see the Good.**



How can you see through dirty glasses?

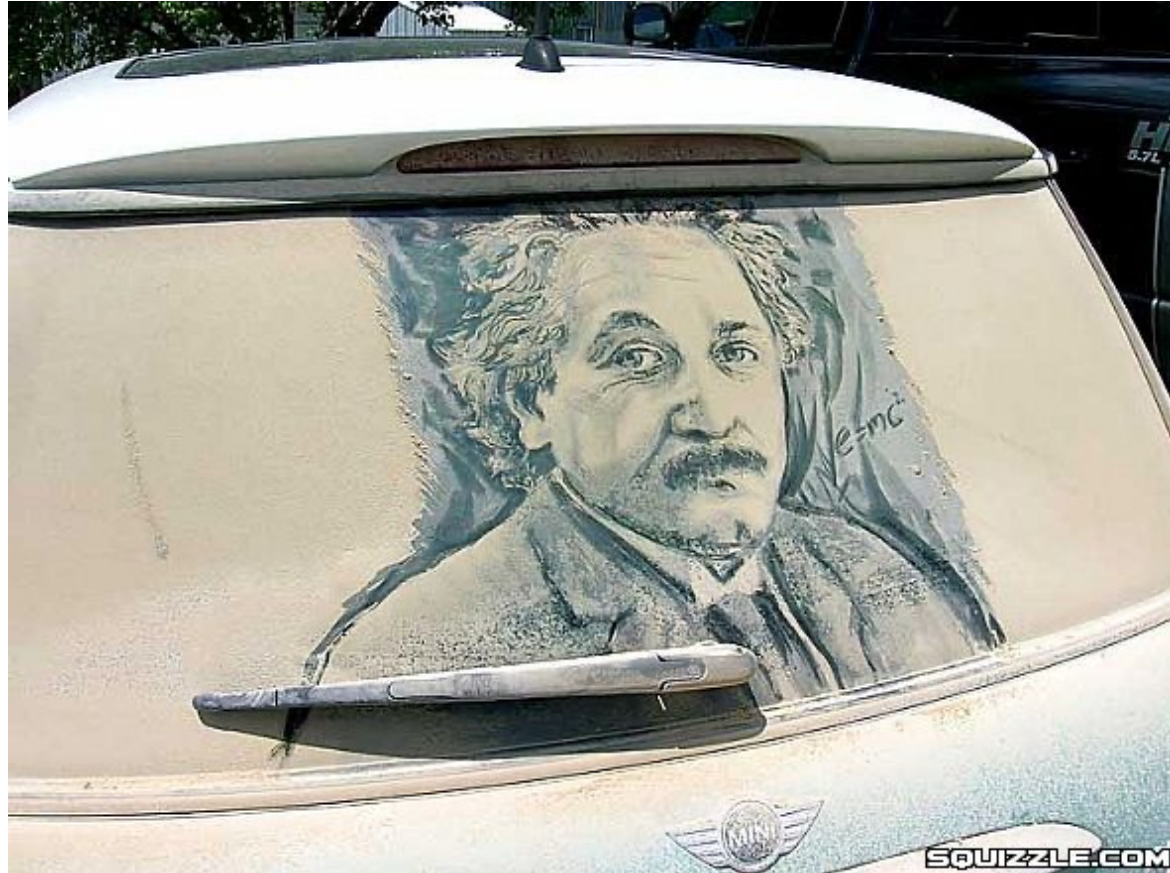

Usually, you see past the dust (forest/trees).  
If you can't, it's time to do windows!  
(Is mote or plank pattern in your eye?)

**The truth can be covered in camouflage.**



**Can we see past the camouflage?  
What if there is real information in the patterns?  
What if it keyed the identity of particular groups?**

# New Currency Watermark

Sometimes there is information hidden in the image.



Can we tell the genuine article from a counterfeit?  
It takes very close information, or a special tool.

# Muddy License Plate

**Criminals put mud on their license plate to hide from the law.**



**Does our own mudslinging accomplish the same purpose?**

**The god of this age has **blinded**  
the minds of unbelievers,  
so that they **cannot see** the light  
of the gospel of the glory of Christ,  
who is the image of God.**

**2 Corinthians 4:4**

**We cannot let the mud build up,  
but must continually be washing it off.**

## False Teachers Cover the Truth

They will be paid back with harm  
for the harm they have done.

Their idea of pleasure is to carouse in broad daylight.

They are **blots** and **blemishes**,  
reveling in their pleasures  
while they feast with you.

2 Peter 2:13

We must keep it clean as much as in our power.

## Only Christ can Truly Uncover the Truth

**But now he has reconciled you  
by Christ's physical body  
through death  
to present you holy in his sight,  
without blemish and free from accusation --  
if you continue in your faith,  
established and firm,  
not moved from the hope held out in the gospel.**

**Colossians 1:22**

Do we see through a glass darkly?



Or do we see through rose-colored glasses?



**Do we look at the Truth through a filter or veil?**

**Therefore, since we have such a hope, we are very bold.**

**We are not like Moses,  
who would put a **veil** over his face  
to keep the Israelites from gazing at it  
while the radiance was fading away.**

**But their minds were made dull,  
for to this day the same **veil** remains  
when the old covenant is read.**

**It has not been removed, because only in Christ is it  
taken away.**

**2 Corinthians 3:12-14**

**We must continually work to remove the filter or veil.**

Even to this day when Moses is read,  
a **veil** covers their hearts.

But whenever anyone turns to the Lord,  
the **veil** is taken away.

Now the Lord is the Spirit,  
and where the Spirit of the Lord is, there is freedom.

**2 Corinthians 3:12-14**

**Only our contact and relationship with the Lord  
can take the veil away so that we can see  
the unvarnished truth.**

In him we have redemption through his blood,  
the forgiveness of sins,  
in accordance with the riches of God's grace  
that he lavished on us  
with all wisdom and understanding.

And he made known to us the **mystery** of his will  
according to his good pleasure,  
which he purposed in Christ,  
to be put into effect  
when the times will have reached their fulfillment —  
to bring all things in heaven and on earth together  
under one head, even Christ.

Ephesians 1:7-10

**God's mystery covered, then revealed the Truth.**

I have become its servant  
by the commission God gave me  
to present to you the word of God in its fullness —  
the **mystery that has been kept hidden**  
for ages and generations,  
but is **now disclosed** to the saints.

To them God has chosen to **make known**  
among the Gentiles  
the glorious riches of this **mystery**,  
which is Christ in you,  
the hope of glory.

**Colossians 1:25-27**

# Covering: Invisibility also works!

Have you ever wanted to be invisible?



**Invisibility also hides things!  
We may not see forest or trees!**

# **It is easy to become confused in our view**

16

**The nights on Fontana Dam as seen from the trail.**



**It looked like we were heading in the wrong direction because we did not understand the complete picture of the landscape. (and we were really, really tired!)**

# **It is easy to become confused in our view**

**The nights on Fontana Dam as seen from the trail.**

**The same idea is true in terms of the problems of life.**

**Things may appear backwards,  
but we do not know all of the facts  
or the complete plan of God.**

**From chaos (mist, fog, smoke, darkness, etc),  
our understanding of the truth emerges.**

# Jesus presented pictures of the Truth

**He painted pictures with words and stories.**

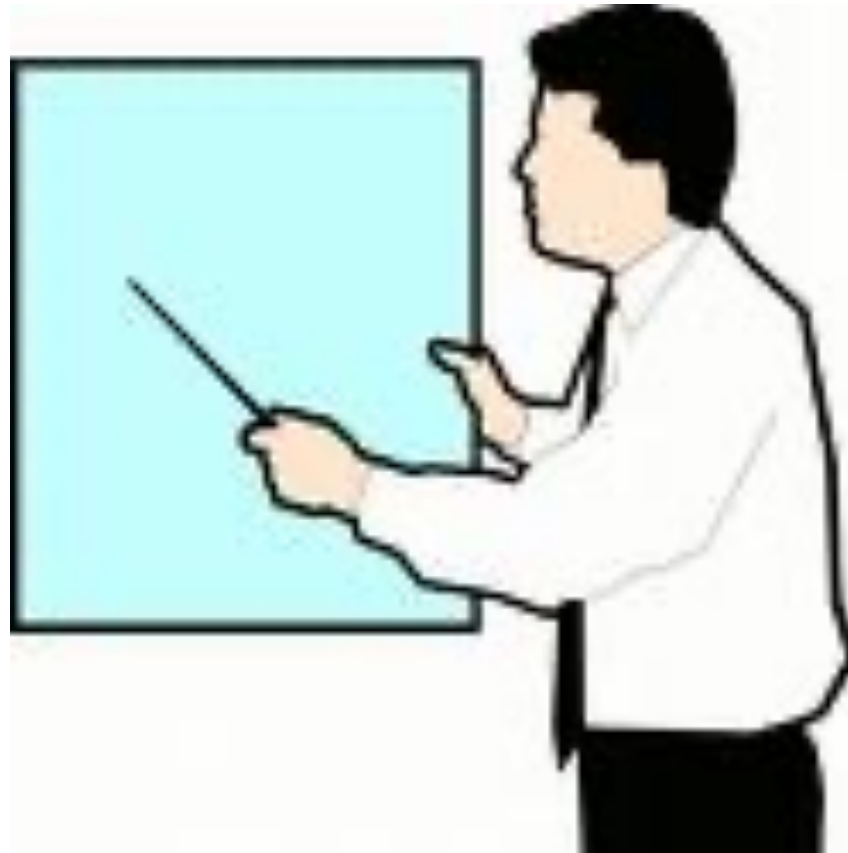

**Jesus could not convince them, though he continually showed images of what that kingdom would be like.**

**Their vision was clouded by their own interests.**



Some try to disguise the Truth to confuse us.

16

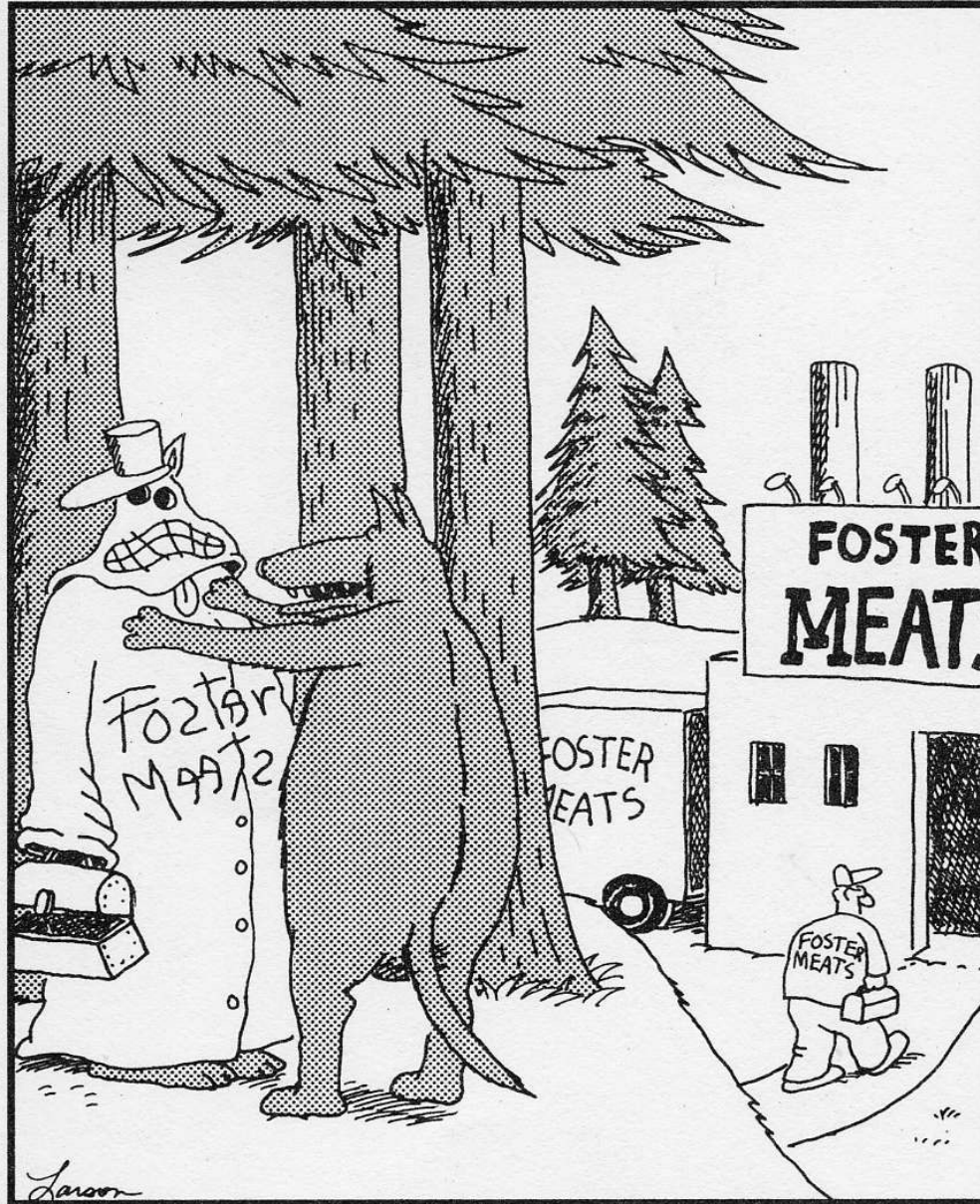

“OK, let’s take a look at you.”

# The Gibeonites disguised themselves

However, when the people of Gibeon heard what Joshua had done to Jericho and Ai, they resorted to a ruse:

They went as a delegation whose donkeys were loaded with worn-out sacks and old wineskins, cracked and mended.

The men put worn and patched sandals on their feet and wore old clothes.

All the bread of their food supply was dry and moldy.

Then they went to Joshua in the camp at Gilgal and said to him and the men of Israel, "We have come from a distant country; make a treaty with us."

Joshua 9:3-6

They fooled Joshua because he didn't check with God.

# People disguise themselves as Good.

**"Watch out for false prophets.**

**They come to you in sheep's clothing,  
but inwardly they are ferocious wolves.**

**By their fruit you will recognize them.** **If you keep watching!**

**Do people pick grapes from thornbushes,  
or figs from thistles?**

**Matthew 7:15-16**

# Satan also disguises himself as Good.

For such men are false apostles,  
deceitful workmen,  
**masquerading** as apostles of Christ.

And no wonder,  
for Satan himself **masquerades**  
as an angel of light.

It is not surprising, then,  
if his servants **masquerade**  
as servants of righteousness.

Their end will be what their actions deserve.

**2 Corinthians 11:13-15**

**We must train ourselves to be able to perceive  
the true pattern through the confusion**

**Satan tempted Christ by redirecting his attention to:**

- 1) Hunger**
- 2) Attention**
- 3) Power**

**Matthew 4:1-11**

**But Jesus saw through the False overlaid pattern to the True pattern and would not take the bait.**

# We always need to look out for self-deception. 16

For the time will come

or pattern

when men will not put up with sound doctrine.

Instead, to suit their own desires,

they will gather around them

“Yes” men.

a great number of teachers

to say what their **itching ears** want to hear.

2 Timothy 4:3

There is a visual parallel to itching ears.

There are many confusing factors to filter out. 17

Remember Where's Waldo?



**We can only deform the Truth and lessen its value.**<sup>17</sup>



**Have you ever bent a Slinky past its elastic limit?**



# **When we distort the Truth we ruin it for others**

17

**Have you ever tried to bend back  
a piece of metal into its original shape  
(like a car dent, or unbend a coat hanger)?  
It is very difficult to put it back like it was, because  
part of the structure was so irreversibly torn  
that a return to the original perfection is impossible.**

**Consider the work of God,  
For who is able to straighten what He has bent?  
Ecclesiastes 7.13**

**God has made truth into a certain shape or pattern.  
If we were to try to straighten it perfectly,  
we would find this impossible.**

## How I remodeled a school French Horn



**In the case of the French Horn,  
not only the appearance was affected by the accident,  
but the quality of the sound was marred as well.**

# **It is our duty to present the Truth without flaw** 17

**We are the ambassadors of Christ (1 Corinthians 5:20)**

**The way of peace they do not know;  
there is no justice in their paths.**

**They have turned them into **crooked** roads;  
no one who walks in them will know peace.**

**Isaiah 59:8**

**The truth has been given to us for a time to use,  
and God depends on us to present  
the pure gospel to the world.**

**We must be so very careful not to mess it up.**

**We must not try to reshape the gospel to our own tastes.**

# **This distortion can be an exchange of values**

17

**This is like exchanging price tags in your local store.**

**They exchanged the truth of God for a lie,  
and worshiped and served created things  
rather than the Creator --  
who is forever praised.**

**Romans 1:25**

**We must be able to determine the God-given values.**

# Many people put a spin on the Truth

**They twist the Truth to suit their own purposes.**

**Christ is the Great Physician  
Satan is the Great Spin Doctor**

# Fraser Spiral Illusion

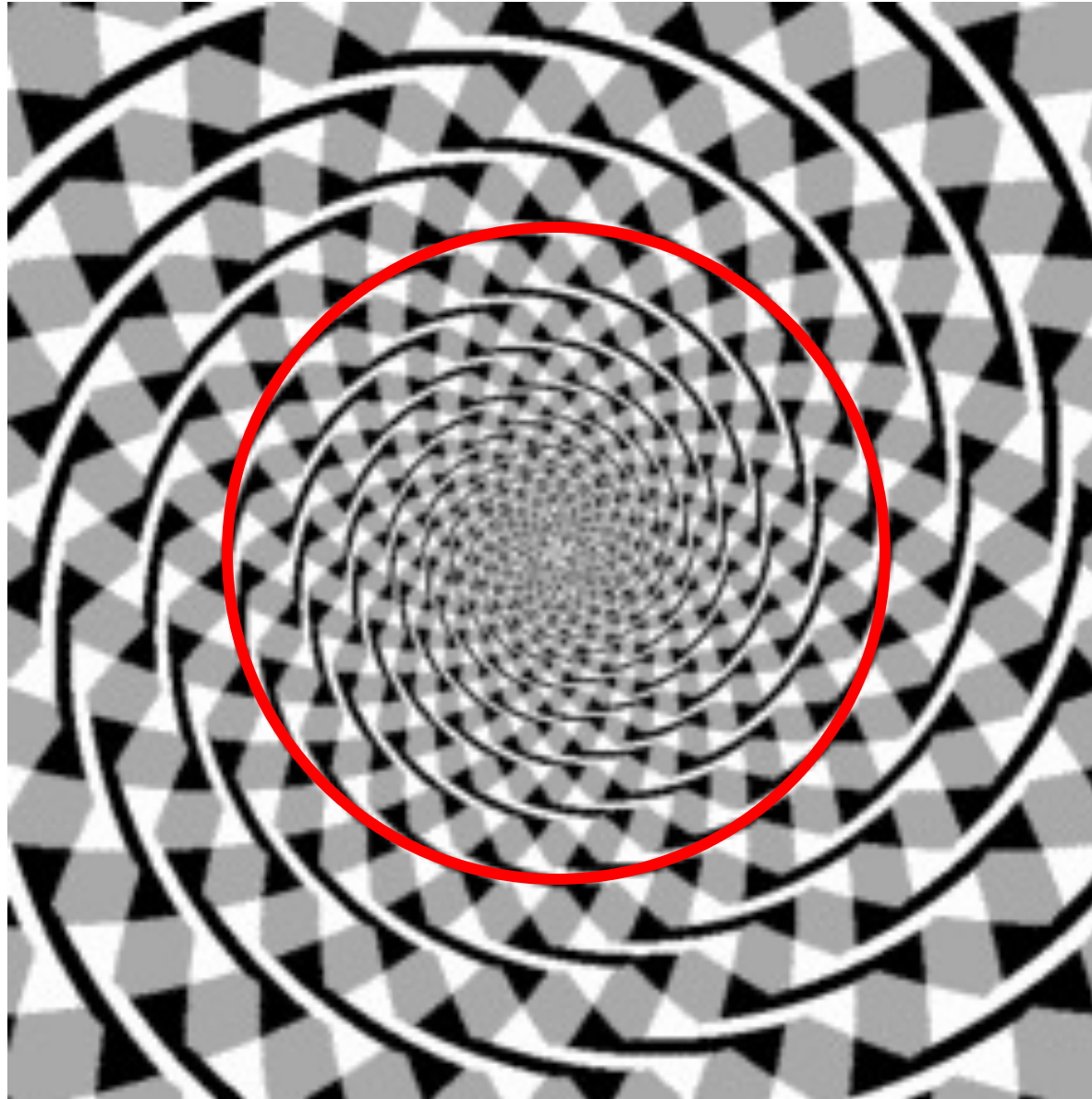

**The spirals are actually circles, purposefully distorted.**

# **Adam and Eve were the first human Spin Doctors<sup>18</sup>**

**First, Satan put a Spin on the only commandment.**

**"You will not surely die,"  
the serpent said to the woman.  
"For God knows that when you eat of it  
your eyes will be opened,  
and you will be like God,  
knowing good and evil."**

**Genesis 3:4-5**

**He minimized the impact of disobedience.**

# **Adam and Eve were the first human Spin Doctors<sup>18</sup>**

**Adam and Eve tried to put a Spin on their Sin.**

**First they clothed themselves and tried to hide.  
But then they had to speak to God.**

**The man said,**

**"The woman you put here with me —  
she gave me some fruit from the tree, and I ate it."**

**Then the LORD God said to the woman,**

**"What is this you have done?"**

**The woman said, "The serpent deceived me, and I ate."**

**Genesis 3:12-13**

**The Spin did not deceive God,  
and He punished all of them.**



# Another Spiral Illusion

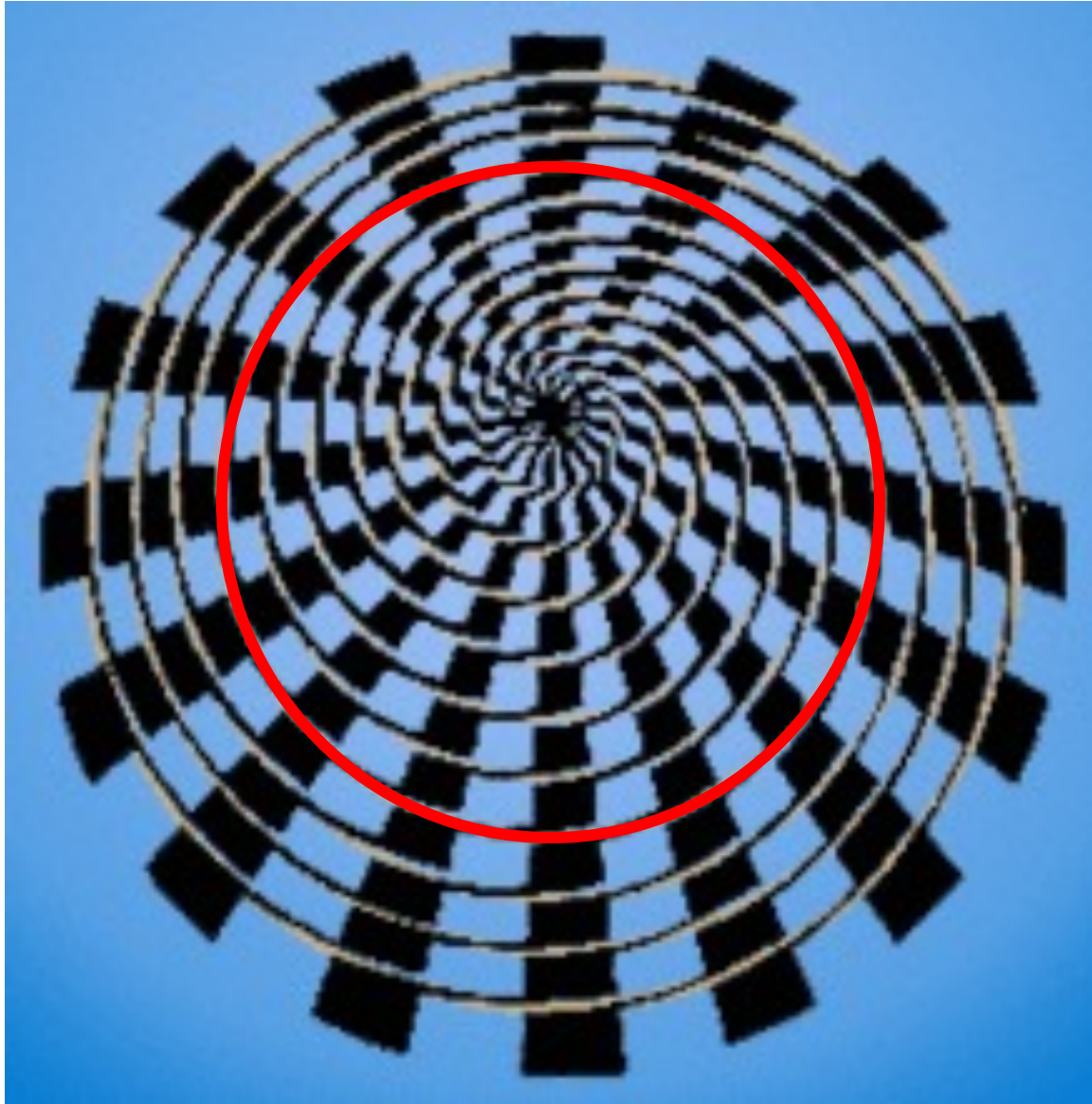

**The background causes the distorted view.**

## **Potiphar's wife also knew how to Spin.**

**She had to explain why Joseph didn't fall for her.**

**When she saw that he had left his cloak in her hand  
and had run out of the house,  
she called her household servants.**

**"Look," she said to them,**

**"this Hebrew has been brought to us  
to make sport of us!**

**He came in here to sleep with me, but I screamed.**

**When he heard me scream for help,  
he left his cloak beside me  
and ran out of the house."**

**Genesis 39:13-15**

**She had to blame someone else for her own sin.**

# A Third Spiral Illusion

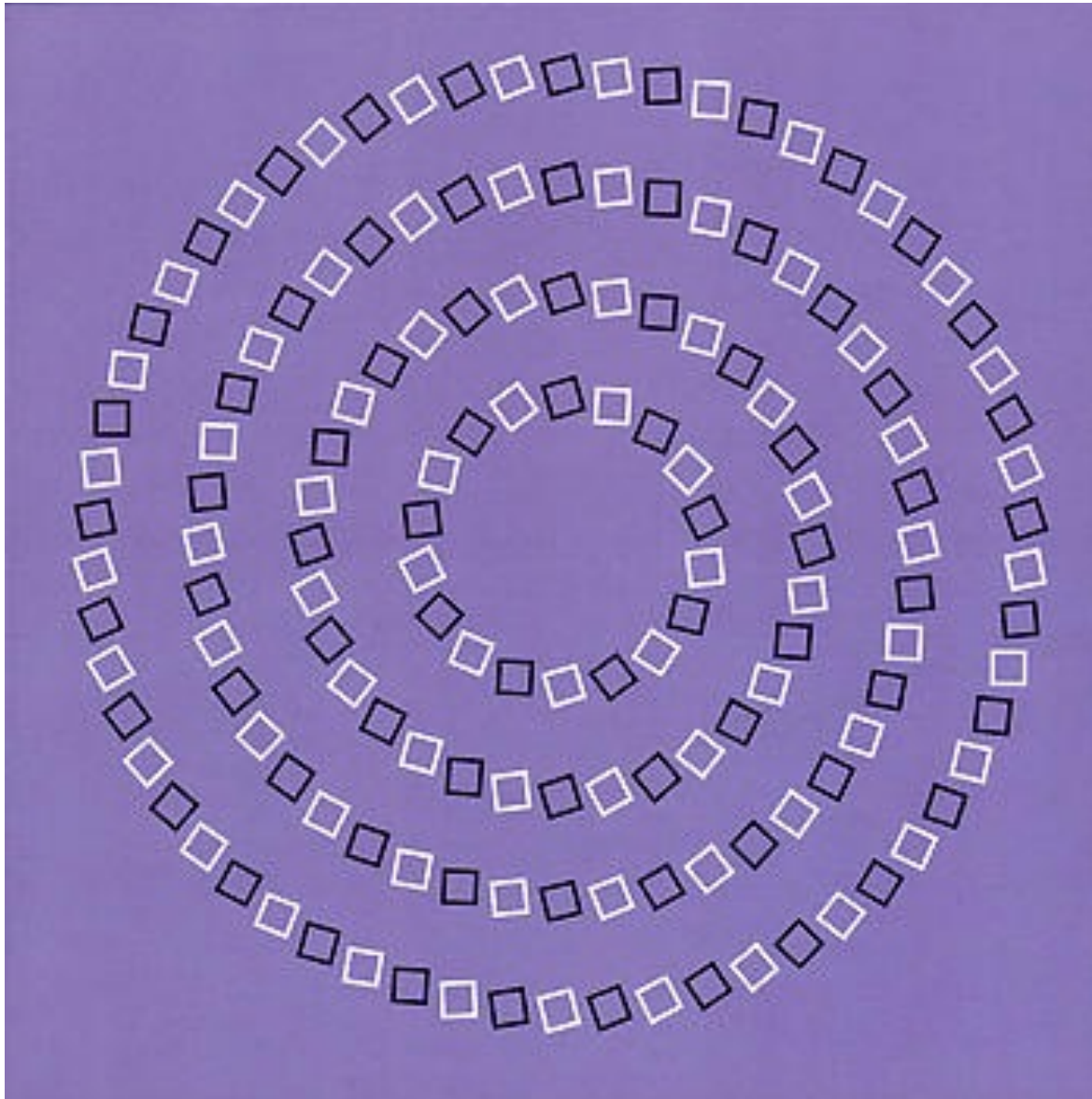

**The tilt of the individual items creates the spin.**

# Saul tried to Spin with Samuel

**Saul did not completely destroy the Amalekites**

**"But I did obey the LORD," Saul said.**

**"I went on the mission the LORD assigned me.  
I completely destroyed the Amalekites  
and brought back Agag their king.**

**The soldiers took** sheep and cattle from the plunder,  
the best of what was devoted to God,  
**in order to sacrifice them  
to the LORD your God** at Gilgal."

**Genesis 39:13-15**

**He blamed others, and made it look like he was going to  
turn it for Good.**

# Saul tried to Spin with Samuel

Saul tried to Spin even by admitting his guilt

Then Saul said to Samuel,

"I have sinned.

I violated the LORD's command and your instructions.

**I was afraid of the people** and so I gave in to them.

Now I beg you,

forgive my sin and come back with me,

so that I may **worship** the LORD."

Genesis 39:13-15

He blamed the people next.

He was not afraid enough of God,  
and was probably looking at the riches he could have.

**Do not be deceived:**

**God cannot be mocked.**

**A man reaps what he sows.**

**The one who sows to please his sinful nature,  
from that nature will reap destruction;  
the one who sows to please the Spirit,  
from the Spirit will reap eternal life.**

**Galatians 6:7-8**

**God can counter any spin we try.**

# The Illusions of Pharaoh's Magicians

## **Snakes:**

**... the Egyptian magicians also did the same things  
by their secret arts:**

**Each one threw down his staff and it became a snake.  
But Aaron's staff swallowed up their staffs.**

## **Plague of blood and frogs:**

**But the Egyptian magicians did the same things  
by their secret arts...**

**Exodus 7-8**

**The magicians were able to duplicate these miracles by  
their tricks.**

# The Illusions of Pharaoh's Magicians

**Plague of gnats:**

**But when the magicians tried to produce gnats  
by their secret arts,  
they could not...**

**The magicians said to Pharaoh,  
"This is the finger of God."**

**Exodus 7-8**

**The illusionists realized that they were outmatched.  
This may have been a plea to Pharaoh to give up.**



# Disguise



When the monster came, Lola, like the peppered moth and the arctic hare, remained motionless and undetected. Harold, of course, was immediately devoured.

# Disguise

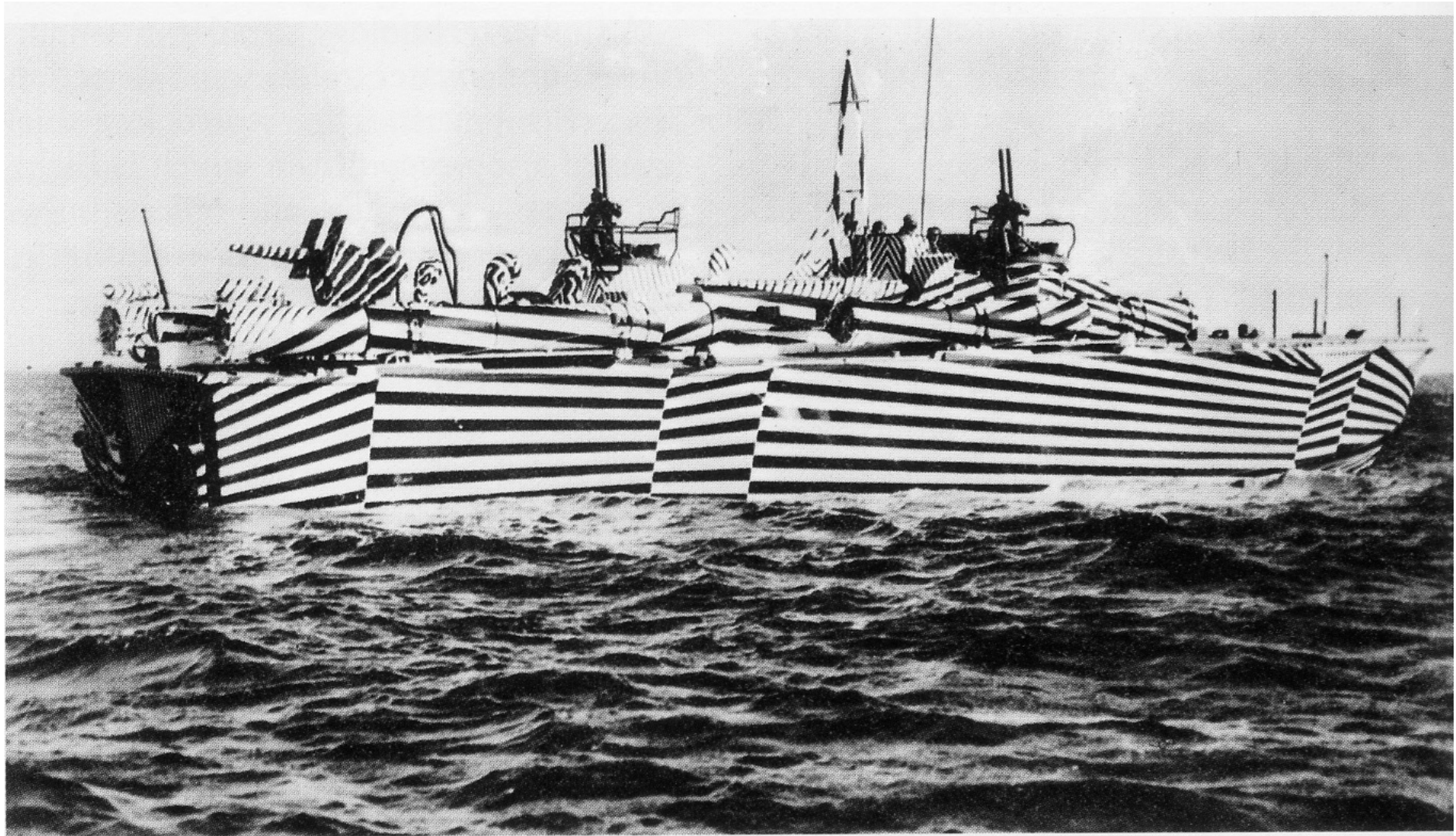

**The appearance of multiple bows (more boats).**

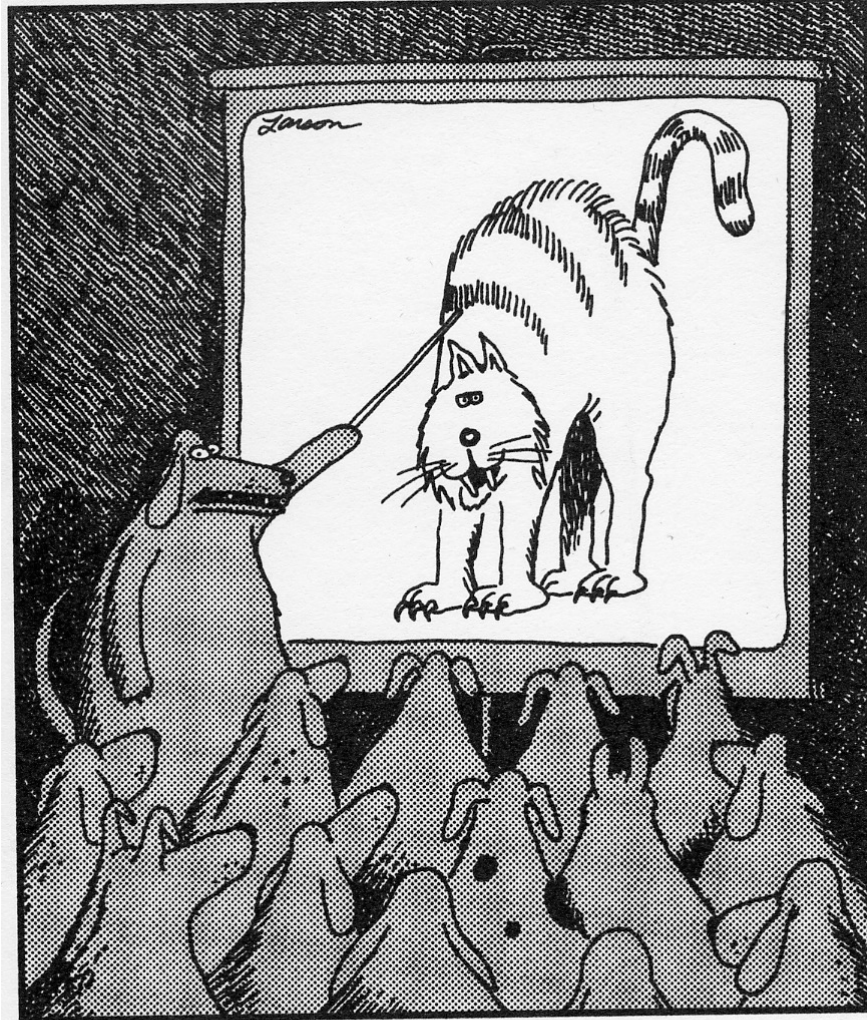

“Now, in this slide we can see how the cornered cat has seemed to suddenly grow bigger. ...  
Trickery! Trickery! Trickery!”

**The appearance of a larger size**

# Perspective: God vs Man

**God is the Greatest,  
we are the worst;  
God is everything,  
we are nothing;  
God is the absolute creator of the universe,  
we are absolutely weak.**

**Then Abraham spoke up again:**

**"Now that I have been so bold  
as to speak to the Lord,  
though **I am nothing but dust and ashes,****

**Genesis 18:27**

**Read: Your God is Too Small (J.B. Phillips)**

# The Illusion of Evolutionary Theory

**It is to this discontinuous record,  
so much in contradiction with the Darwinian concept  
that nature does not make jumps  
in the evolutionary process,  
that Niles Eldredge referred when he said,  
“The **pattern** we were told to find  
for the past 120 years  
**does not exist.**”**

**Gerald Schroeder**

# Delusion comes from refusing to love the Truth <sup>19</sup>

The coming of the lawless one

will be in accordance with the work of Satan  
displayed in all kinds of

**counterfeit** miracles, signs and wonders,  
and in every sort of evil

that **deceives** those who are perishing.

They perish because they refused to love the truth  
and so be saved.

For this reason God sends them a **powerful delusion**

so that they will believe the **lie**

and so that all will be condemned

who have not believed the truth

but have delighted in wickedness.

2 Thessalonians 2:8-12

# We must not be lured away from the True Pattern<sup>19</sup>



## Attributes of the Bait:

color

flash

dynamic

... each one is tempted when, by his own evil desire, he is dragged away and enticed.

James 1:14

For us, what we want to see to satisfy our desires.

# Illusion: Sometimes we see things in Reflection: <sup>19</sup>

same formula (appearance) -- different results  
check not just the appearance, but the true structure

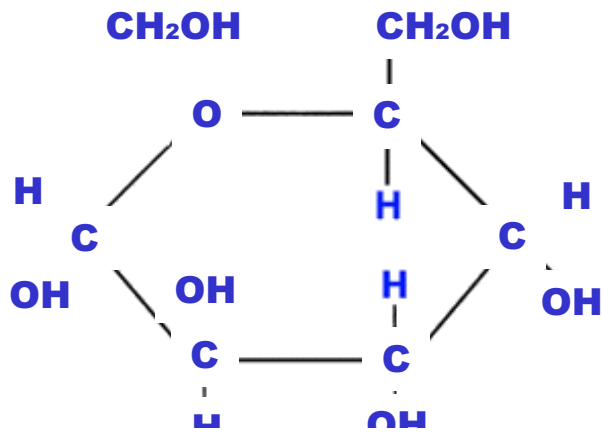

left-handed glucose

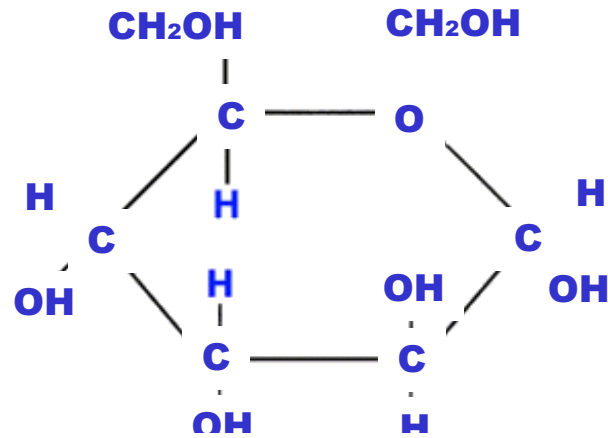

right-handed glucose

Only right-handed sugars are used by our body.

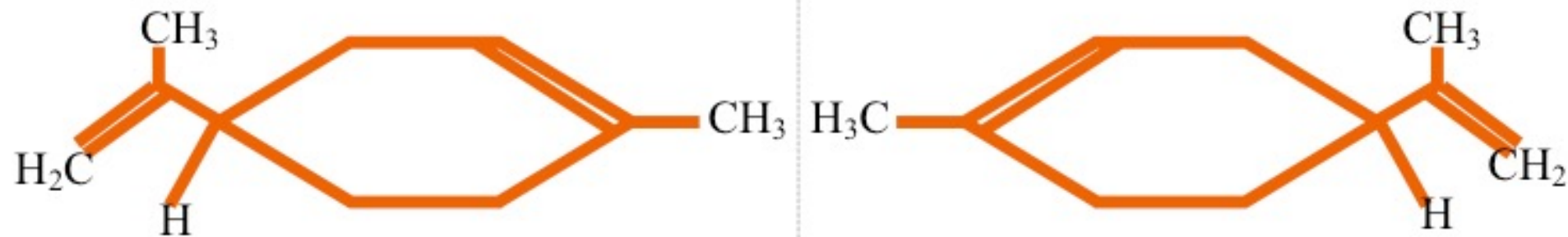

left-handed limonene

right-handed limonene

Oranges have the left-handed; Lemons have the right.



# **We are tricked by the illusion of strength**

**'This is what the great king, the king of Assyria, says:**

**On what are you basing this confidence of yours?**

**You say you have strategy and military strength —  
but you speak only empty words.**

**On whom are you depending, that you rebel against me?**

**Look now, you are depending on Egypt,**

**that splintered reed of a staff,**

**which pierces a man's hand and wounds him  
if he leans on it!**

**2 Kings 18:8-12**

**The Israelites kept trying to lean on other gods (e.g., Baal).  
We must lean only on God.**

# **Sometimes there is a pattern within a pattern and there are levels of meaning**

- Level one: the actual words on the paper**
- Level two: the meaning of those words**
- Level three: reading between the lines  
(allegorical or symbolic meaning)**
- Level four: visual structure of the words  
(acrostic or other pattern)**

**Zach used to recognize we were at McDonalds'  
by looking through the window  
and seeing the golden arches;  
later he could read the word and even the menu.**

**The medium may even be the message.**

# Levels of Meaning

## An Acrostic, by Edgar Allan Poe

**E**lizabeth it is in vain you say

"**L**ove not" — thou sayest it in so sweet a way:

**I**n vain those words from thee or L.E.L.

**Z**antippe's talents had enforced so well:

**A**h! if that language from thy heart arise,

**B**reath it less gently forth — and veil thine eyes.

**E**ndymion, recollect, when Luna tried

**T**o cure his love — was cured of all beside —

**H**is follie — pride — and passion — for he died.

# Levels of Meaning

## A Calendar Acrostic

**JAN**et was quite ill one day.

**FEB**rile trouble came her way.

**MAR**tyr-like, she lay in bed;

**APR**oned nurses softly sped.

**MAY**be, said the leech judicial

**JUN**ket would be beneficial.

**JUL**eps, too, though freely tried,

**AUG**ured ill, for Janet died.

**SEP**ulchre was sadly made.

**OCT**aves pealed and prayers were said.

**NOV**ices with ma'y a tear

**DEC**orated Janet's bier.

# The “Bible Codes”

Intentional coincidences of significant words or phrases that appear as letters with equal spacing

יִשְׁבַּעַל הַבְּאֵר וְלֹכַ  
 בִּי הוֹנֵא יִאֲמַר מִדּוֹ  
 יוֹאֵל מִשְׁהֵא לְשִׁבְתָּא  
 הָעֵבֶדְהוּ יִזְעָקוּ  
 הַהִי הָרַעַה אֶתְצֹא  
 נִוְאֶכְלֵ יִאֲמַר מִשְׁ  
 כְּבִהֵלְשֵׁל נְעֻלֵי  
 לַהִי סוֹנֵא יִמְרֵהוּ  
 רְחִבָּה אֶל אֶן יִבְת

"Thou hast now  
 done foolishly  
 in so doing..."

The claim is that God inspired this code into the Word letter by letter

# Pentateuch -- Torah

Take the first time the Hebrew letter “T” appears in the Hebrew version of the book of Genesis. Note the 50<sup>th</sup> letter three times. The result is TORH (Torah).

Repeat in Exodus and see the same.

In Leviticus take the first letter of the name of God (JHVH - Jehovah). Note the 7<sup>th</sup> letter three times. The result is JHVH.

Now in Numbers and Deuteronomy the word TORH appears backwards at the 50<sup>th</sup> character spacing.

**TORH**  
**(Gen)**

**TORH**  
**(Exo)**

**JHVH**  
**(Lev)**

**HROT**  
**(Num)**

**HROT**  
**(Deu)**

**Torah is a Hebrew word meaning  
"teaching," "instruction," or "law".**

**Where does God indicate that it is a “special” word?**

# Pictures within pictures -- Mosaics



**The component pictures may have no related meaning**

# Making a copy of the complete picture



**The content of the picture is one level,  
but the brushstrokes must be copied as well.**



**Context: We must have the information that allows us to understand the data referred to**

**We are not to worship the creation (stars, etc);  
We are to worship the force that holds it all together!**

**What burnt offering gives a pleasing aroma to God?  
Mindless obedience or steadfast love from the heart?**

**We must understand the structure that supports  
the will and law of God.**

# We need to simplify to find the core of the Truth<sup>21</sup>

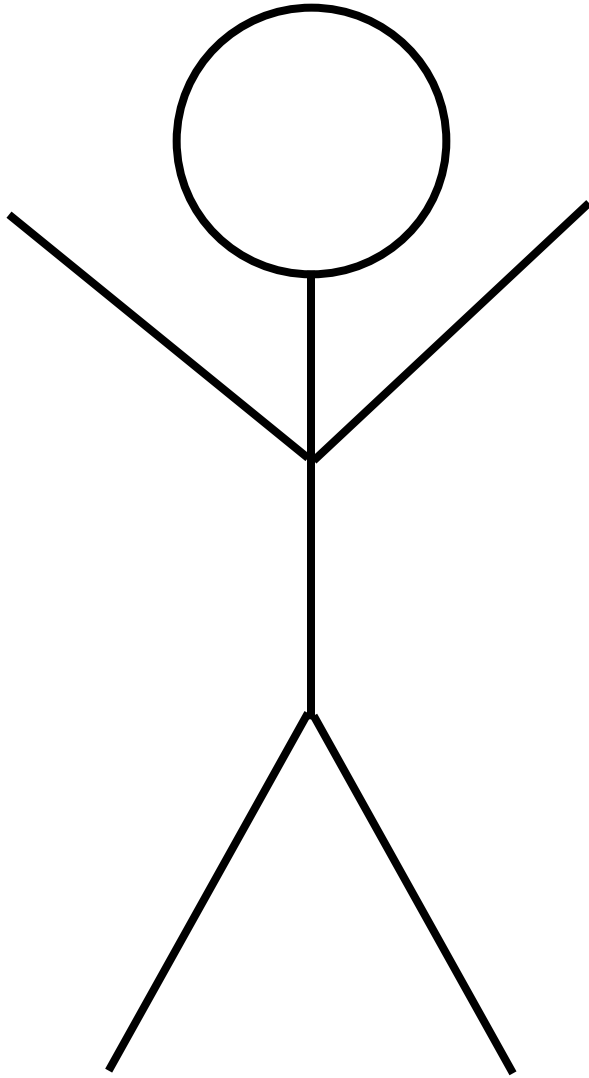

**As children, we  
simplify to the basic  
(essential) structures  
when we draw people.**

# A cross-section helps understand a 3D object 21



“And see this ring right here, Jimmy? ...  
That’s another time when the old fellow  
miraculously survived some big forest fire.”

# **EINSTEIN SIMPLIFIED**



**Cartoons on Science**

**SIDNEY HARRIS**

# Don't simplify too much!

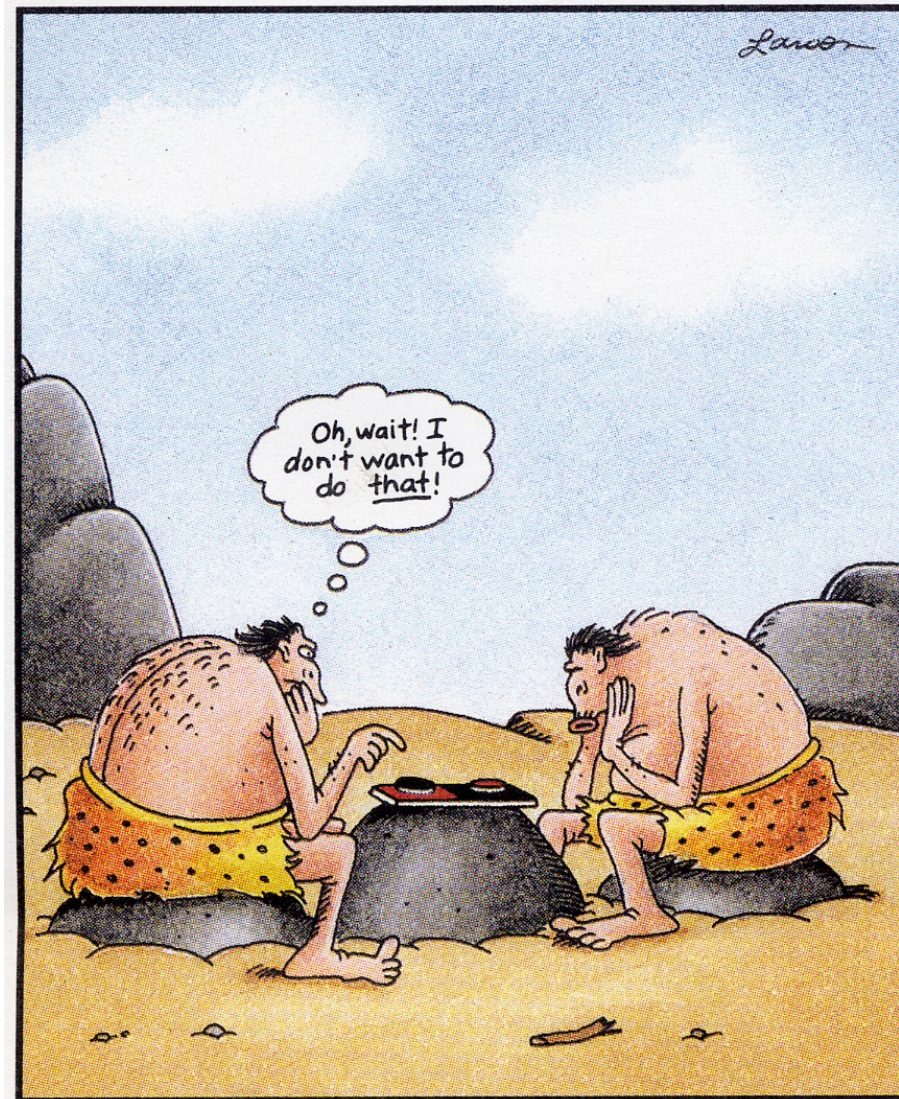

Early checkers

**“All you need to do is love people to be pleasing to God”**

# **Erroneous efforts to simplify can actually complicate matters!**

**Consider man's early attempts  
to understand the universe**

**Beauty of Universe --> Beauty of Geometric Forms**

# The Building Blocks of the Universe

## The five Platonic solids

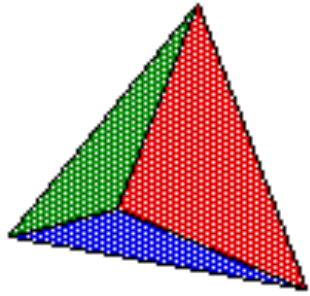

tetrahedron  
Earth

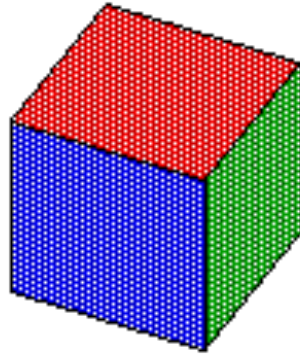

cube  
Water

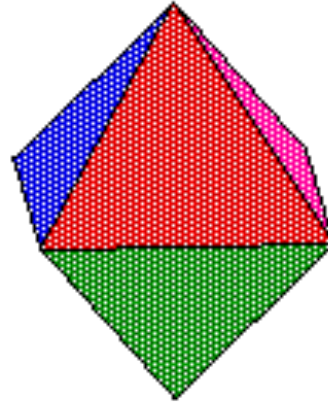

octahedron  
Air

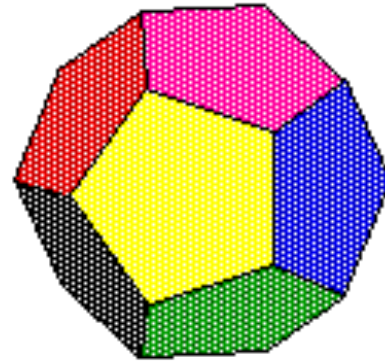

dodecahedron  
Fire

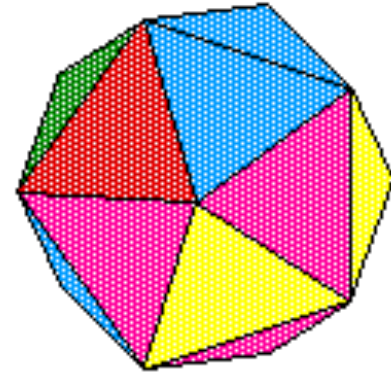

icosahedron  
Quintessence

The “beauty” of the regular solids cause Plato to think that they were linked to the five essential essences of the universe.

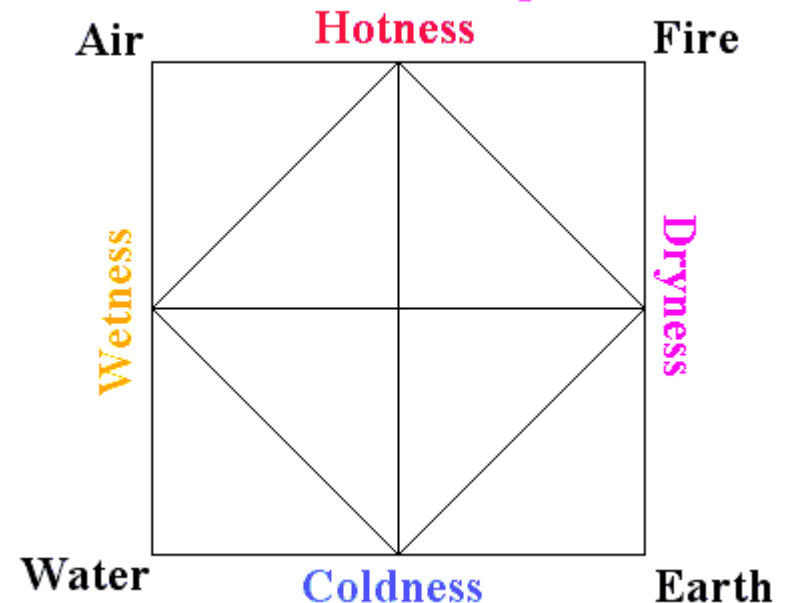

# The Pattern of the Planets

Order of the five planetary orbits in terms of nesting the five regular solids.

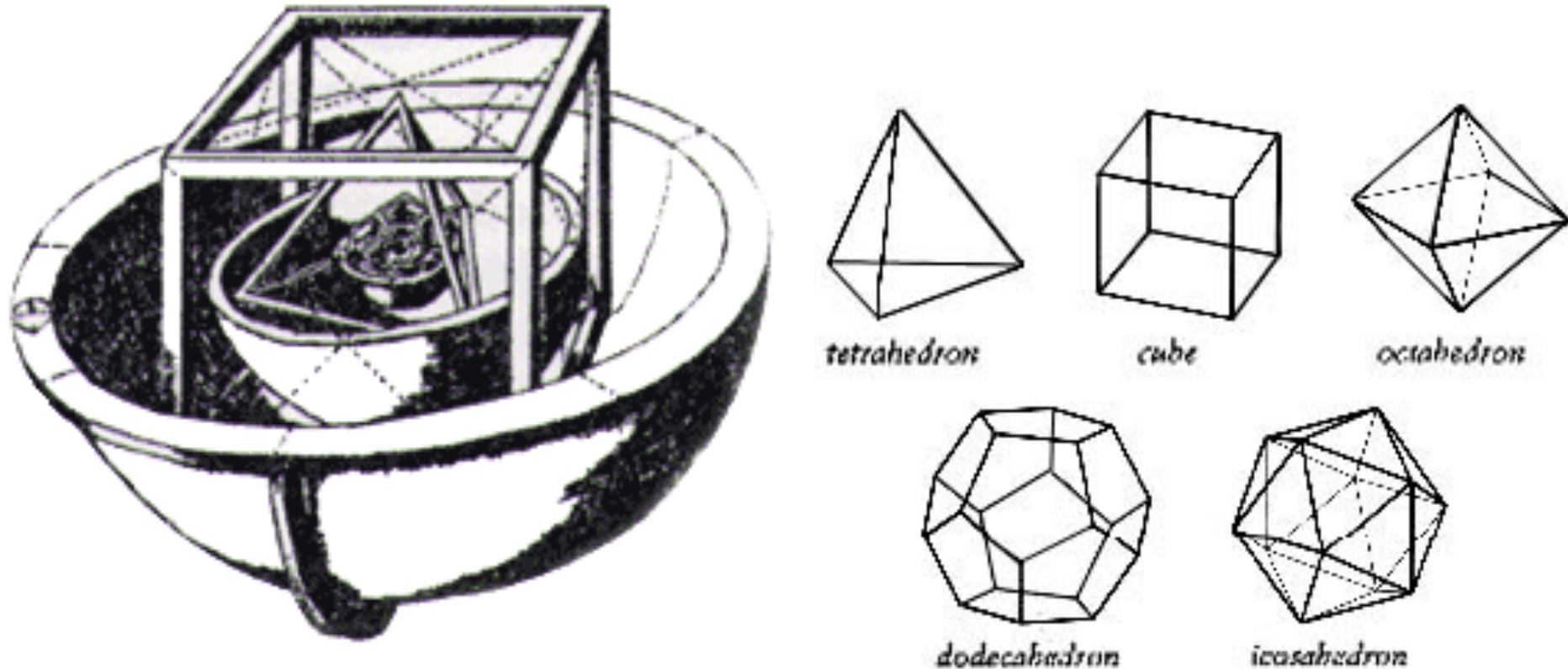

*Figure 4.*

This hypothesis formed the center piece of Kepler's cosmology. Despite rather poor agreement between this model and observations, Kepler would cling to this idea to the end of his life.



# Basic Building Blocks of Truth

So taken was Kepler with this scheme that he went on to assign music intervals to the distances between the planets and sun. You may have come across the phrase, "the music of the spheres."

He also proposed that marriage laws and other civil matters should be related to these solids. I don't know how effective that would have been, but **I do know Kepler had an unhappy marriage.**

Rene Descartes (philosopher, mathematician) discovered a pattern between the number of faces (sides), edges, and vertices (corners) of solids. He kept it secret because he was afraid of the reaction of the Catholic church. Euler rediscovered it, so it became known as Euler's formula.

$$F - E + V = 2$$

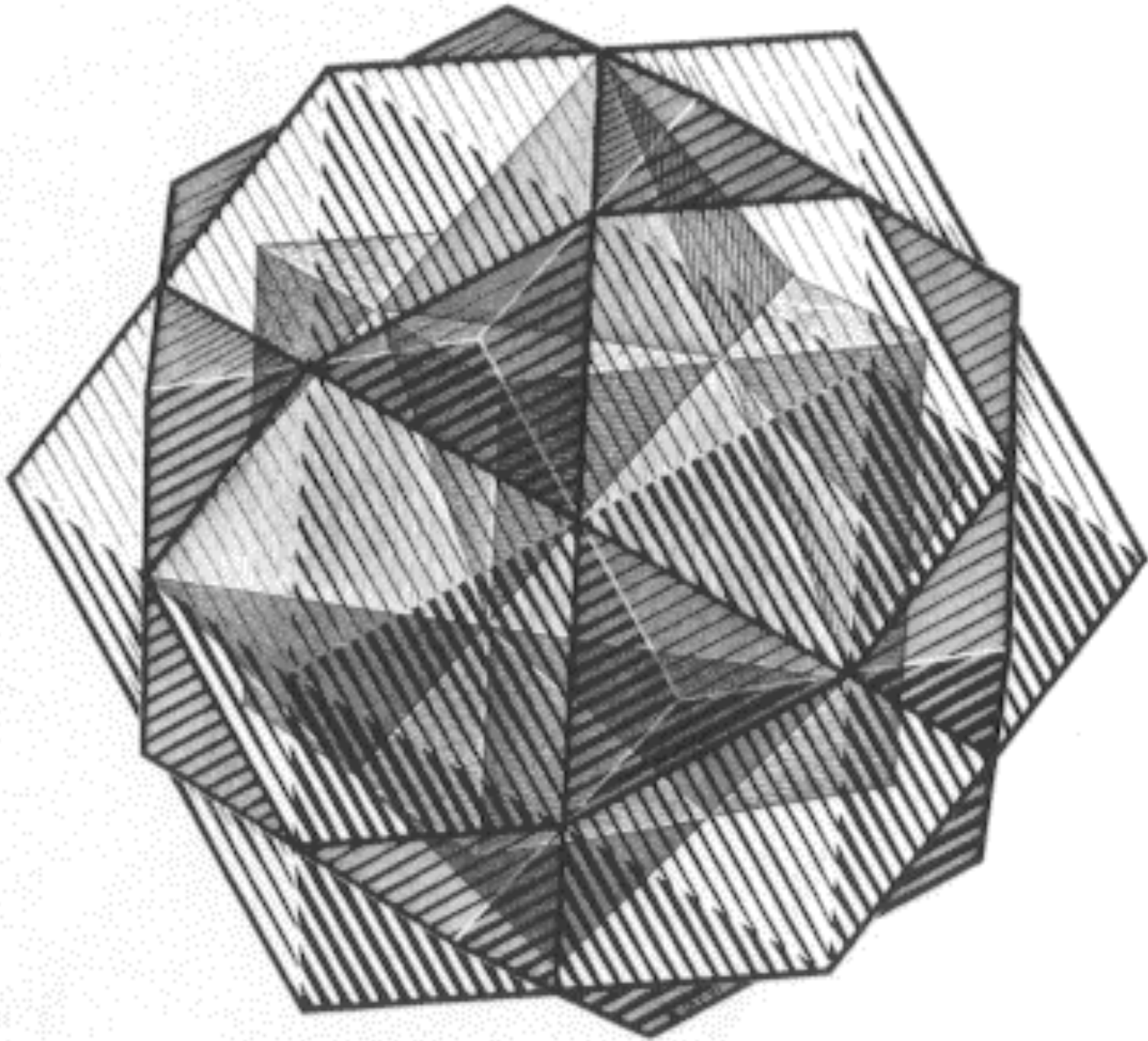

**M.C. Escher – “Four Regular Solids”**

**Message**

# Figure vs Ground



**Christ said that we must become like children...**

# Figure vs Ground -- Music

## Mozart Rondo in D K. 485

W.A. Mozart

Piano

*Accompaniment pattern*

The image displays a musical score for the piano accompaniment of Mozart's Rondo in D, K. 485. The score is written in treble clef with a key signature of one sharp (F#) and a time signature of 4/4. It consists of two staves. The upper staff features a melodic line with a repeating rhythmic pattern of quarter notes and eighth notes. The lower staff provides a harmonic accompaniment consisting of a steady stream of eighth notes, often grouped in pairs. The word 'Piano' is written to the left of the staves, and the phrase 'Accompaniment pattern' is written below the lower staff.

Think how it would feel to accompany Jesus

# Figure vs Ground -- Art

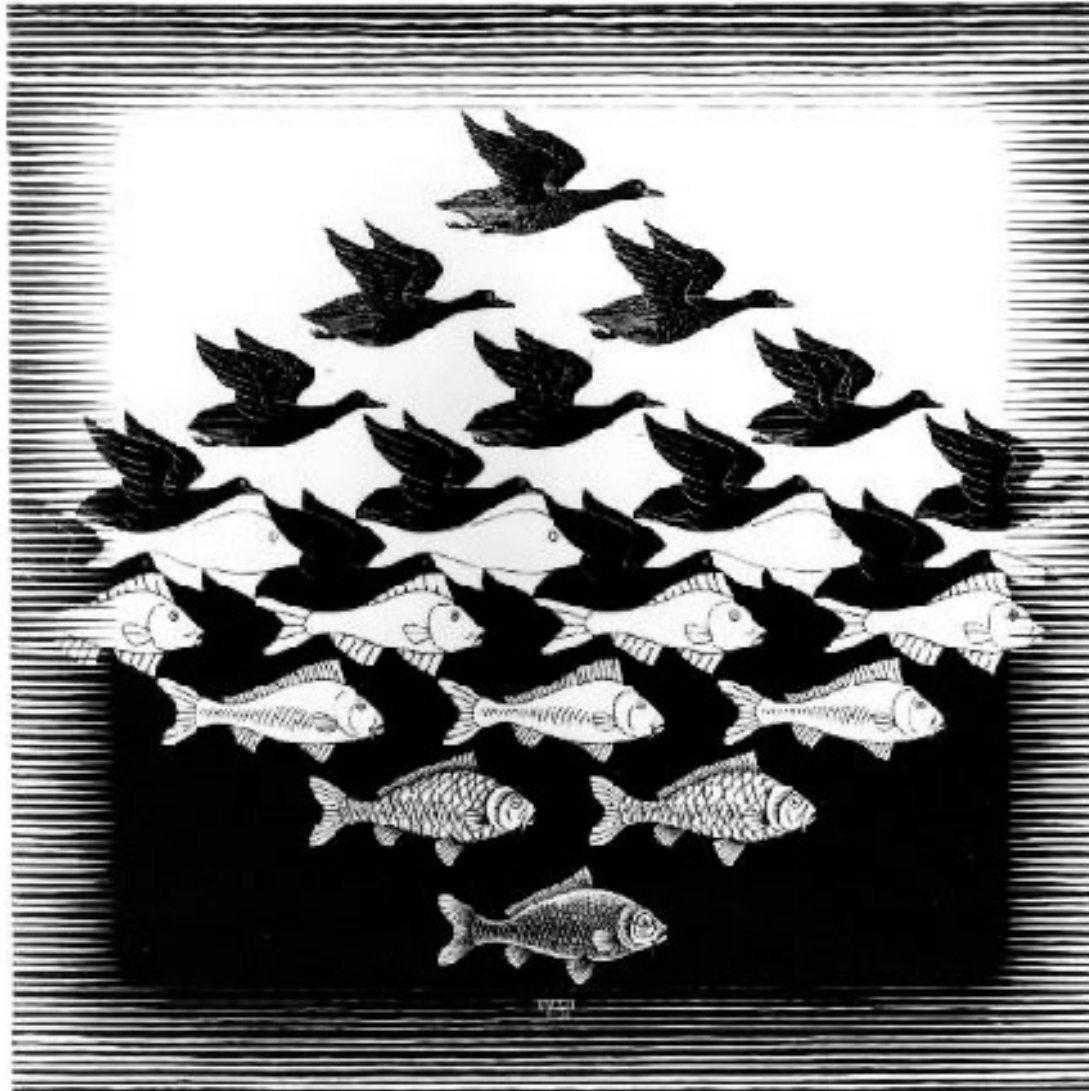

M.C. Escher: *Sky and Water I* 1938 woodcut

**We must be able to see things from both perspectives**

**Our world seems to alternate  
between one driven by seemingly natural causes and  
one that is guided by the will  
and occasional intervention  
of a being that we have labeled “God.”**

**This understanding has at times the quality  
of the uncontrollable sequences  
in which an object in a painting  
may suddenly reorient to become the background.**

**The painter M.C. Escher was a master at creating paintings  
in which such reversals occur  
at the twinkling of an eye.**

**Gerald Schroeder**

**Every true prayer has its background and its foreground.**

**The foreground of prayer**

**is the intense, immediate desire for a certain blessing  
which seems to be absolutely necessary**

**for the soul to have;**

**the background of prayer is the quiet, earnest desire**

**that the will of God,**

**whatever it may be,**

**should be done.**



**What a picture**

**is the perfect prayer of Jesus in Gethsemane!**

**In front burns the strong desire to escape death and to live;**

**but behind there stands, calm and strong,**

**the craving of the whole life**

**for the doing of the will of God...**

**Leave out the foreground,  
let there be no expression of the will of him who prays,  
and there is left a pure submission  
which is almost fatalism.**

**Leave out the background,  
let there be no acceptance of the will of God,  
and the prayer is only an expression of self-will...**

**Only when the two are there together,  
the special desire resting on the universal submission,  
the universal submission opening  
into the special desire,  
is the picture perfect and the prayer complete.**

**Phillips Brooks**

**We must not be defined only by the “shall nots”<sup>23</sup>**



**You  
shall  
not...**

**The “shall’s” are not so obvious or well-defined**

## THE ELEPHANT METAPHOR OF REALITY

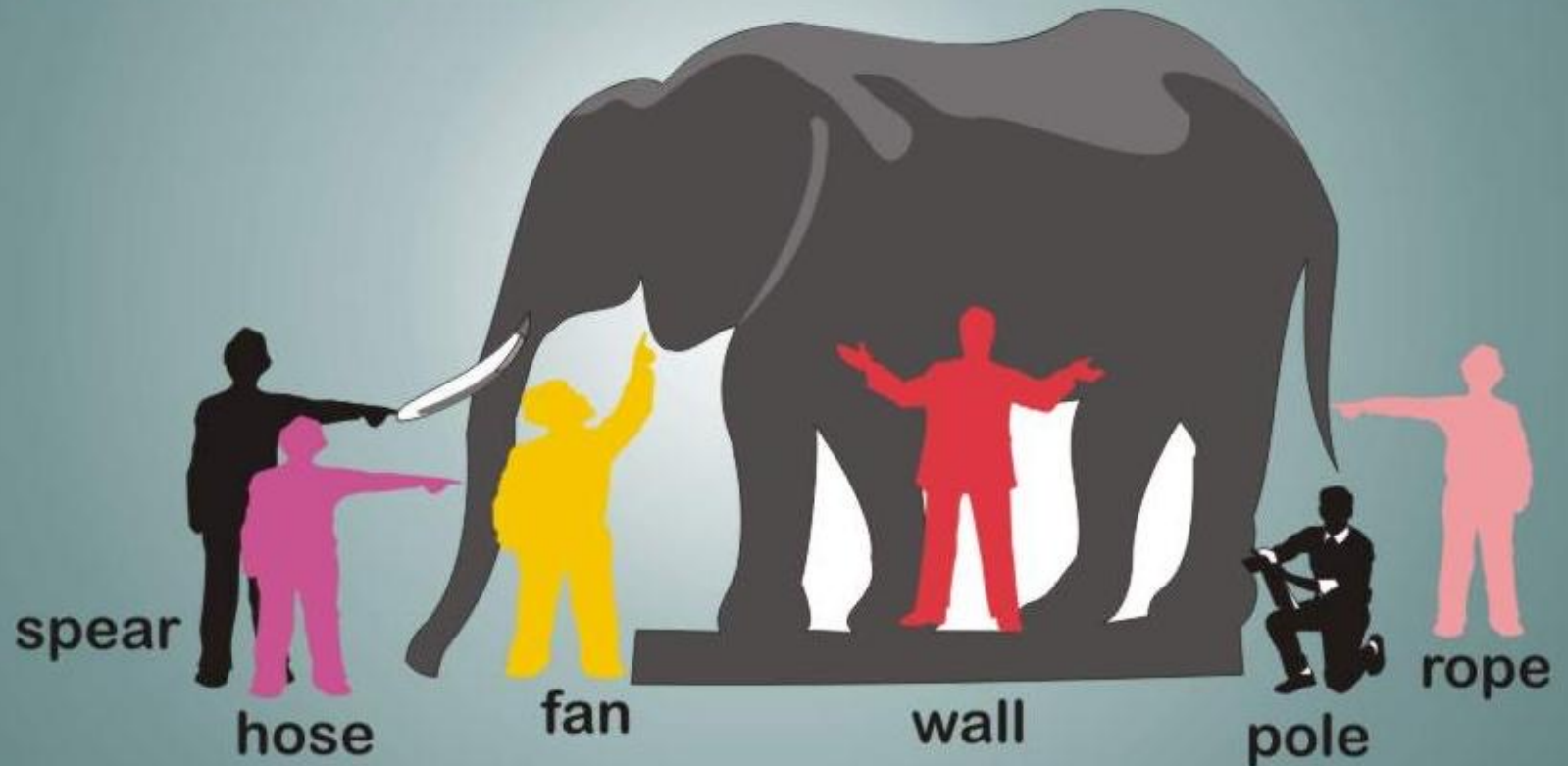

# Does your Perception Signify your Inner Being?<sup>22</sup>



**What does this mean to you?**

**It is the first card in the Rorschach Test deck.**

# Does your Perception Signify your Inner Being?<sup>22</sup>

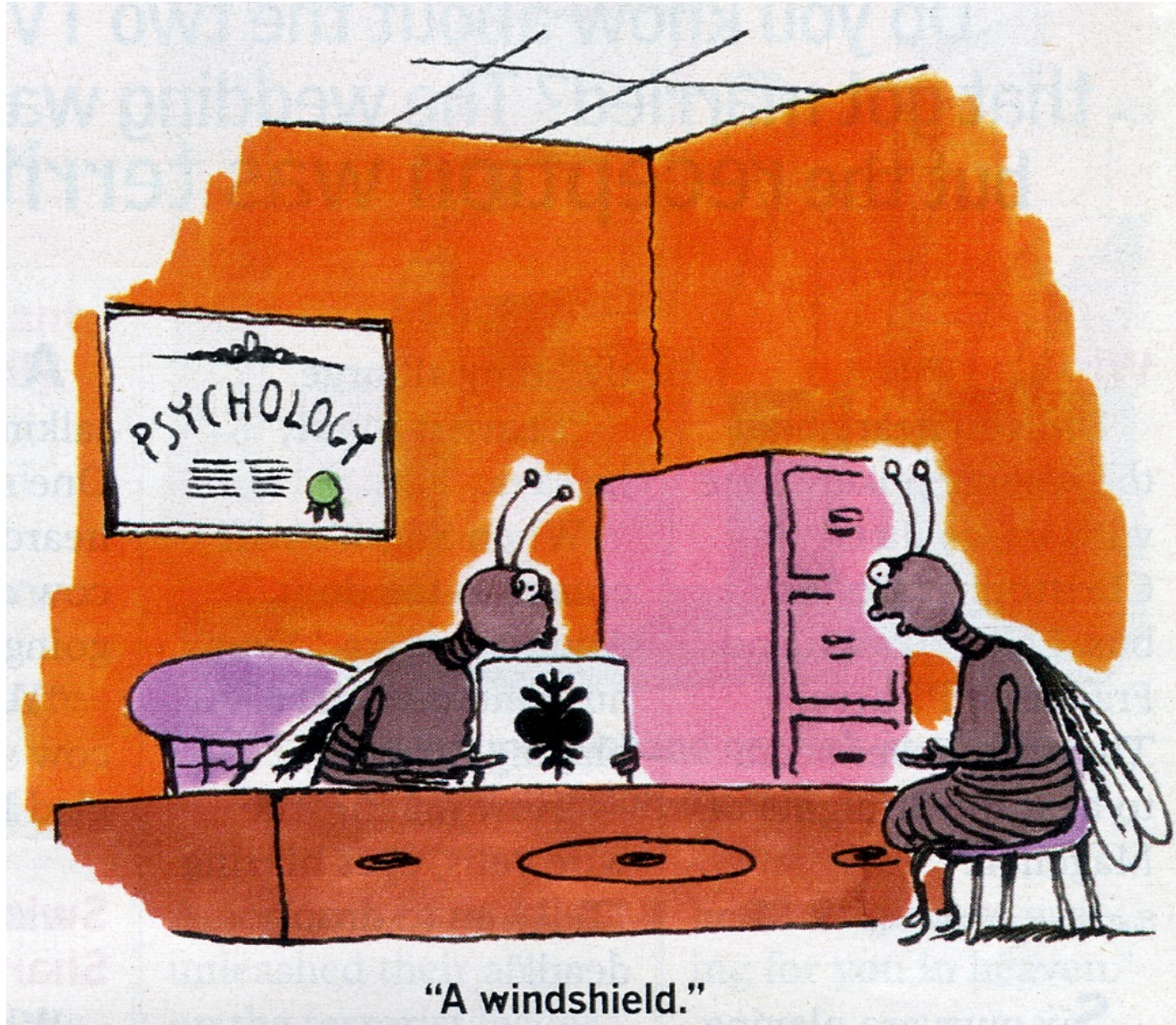

**Our perceptions are linked to our experience.**

# Piano Illusion



# The difference between a human and a computer<sup>22</sup>

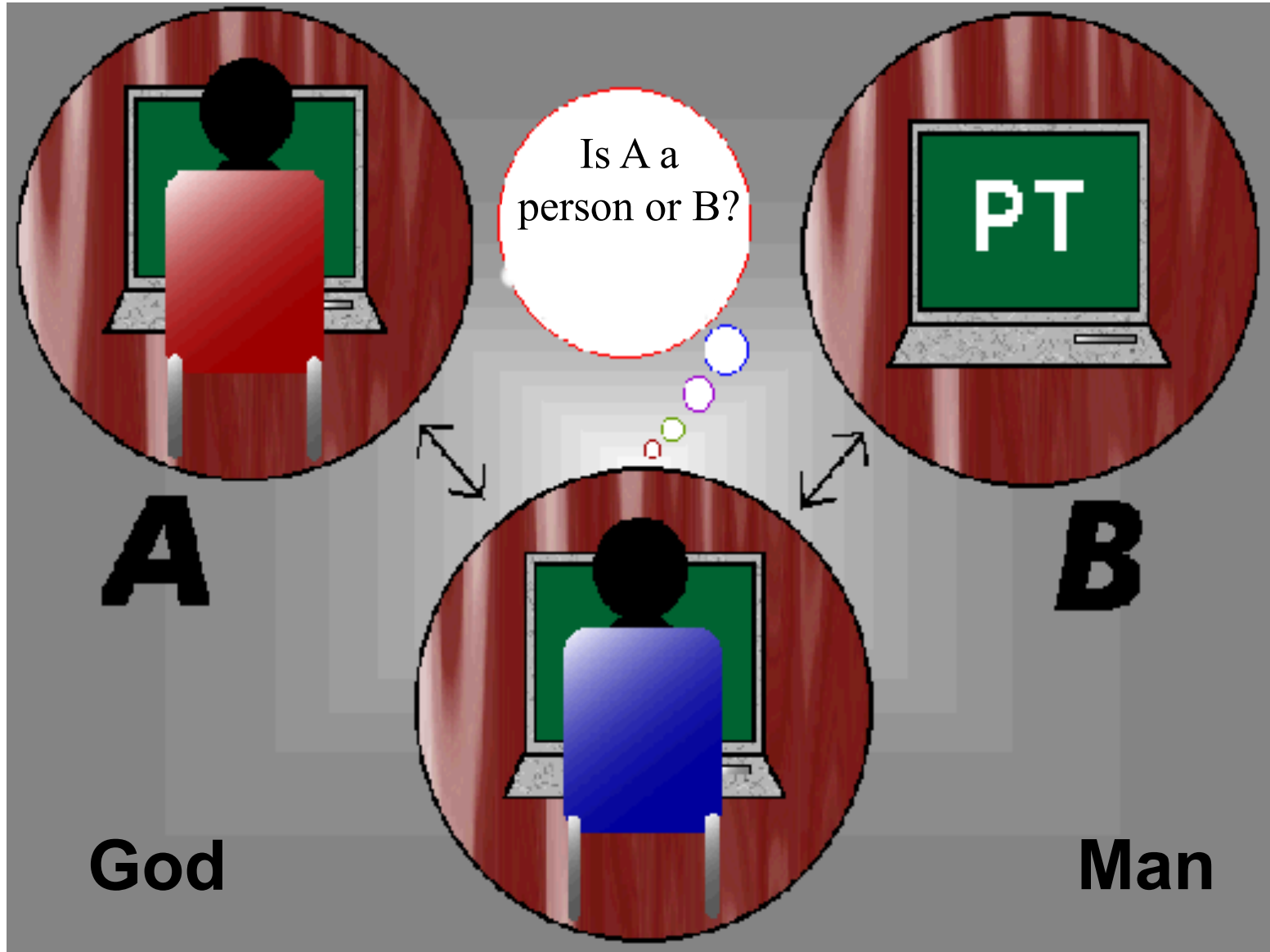

One day you may not be able to tell



# Using Patterns to Chart the Night Sky

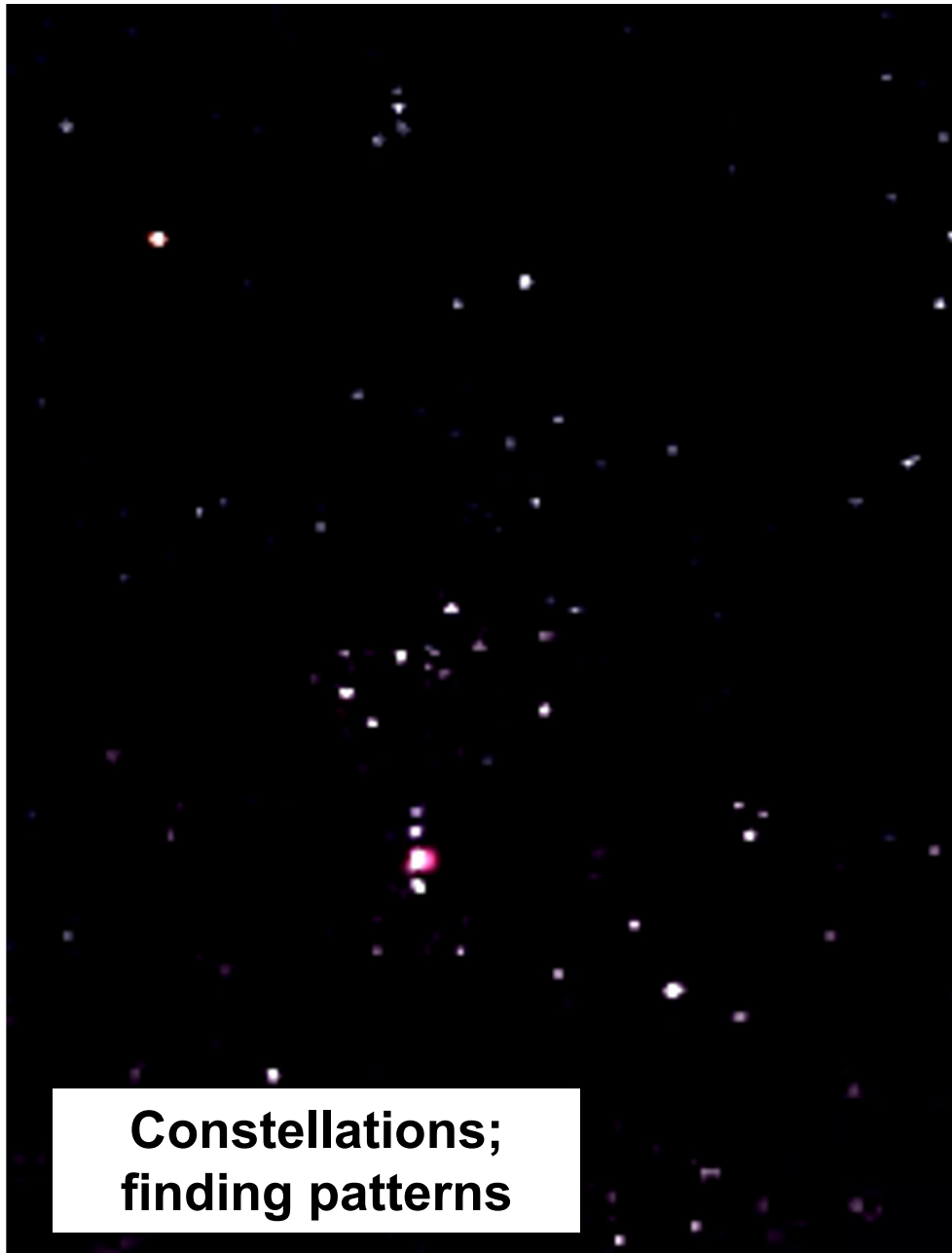

Constellations;  
finding patterns

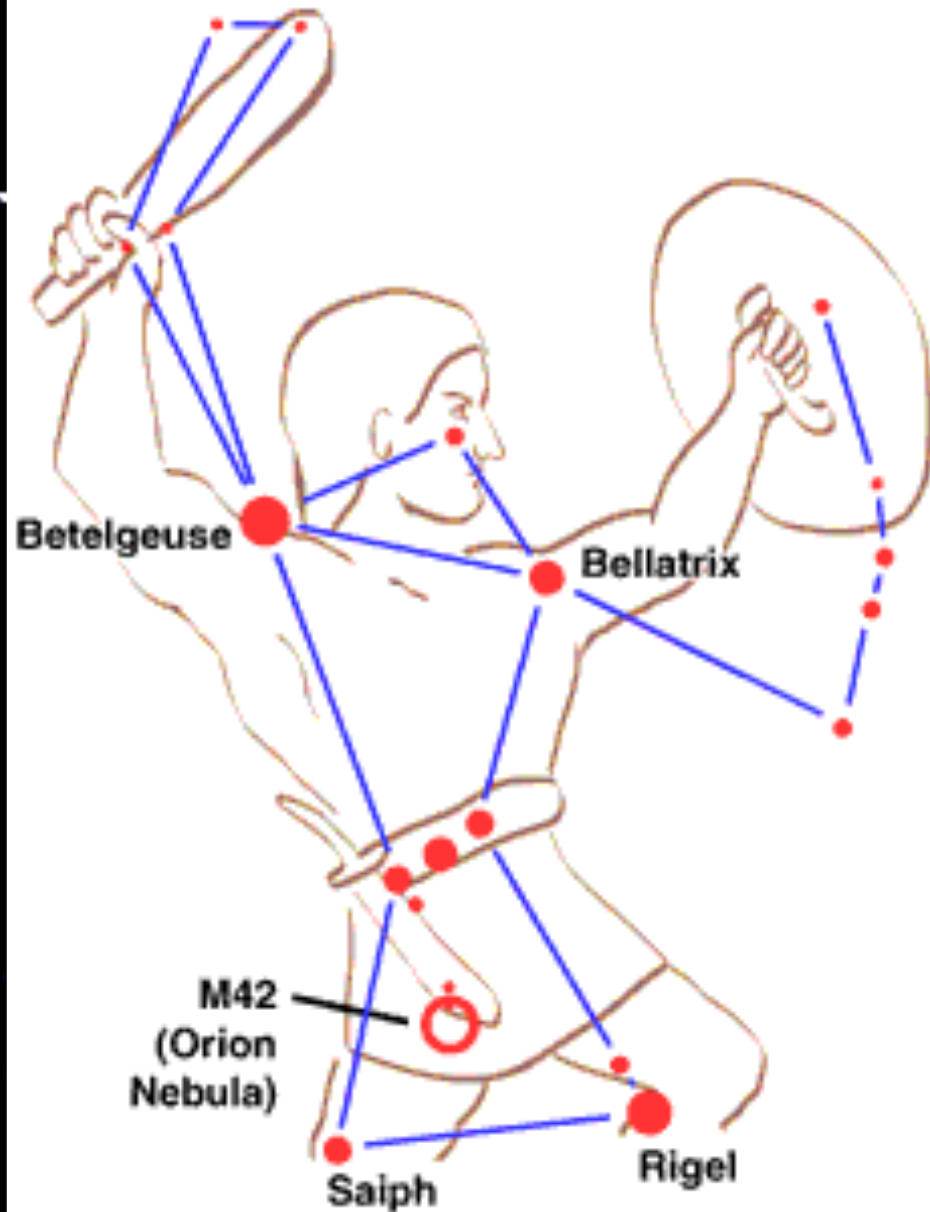

# Star Patterns become Constellations

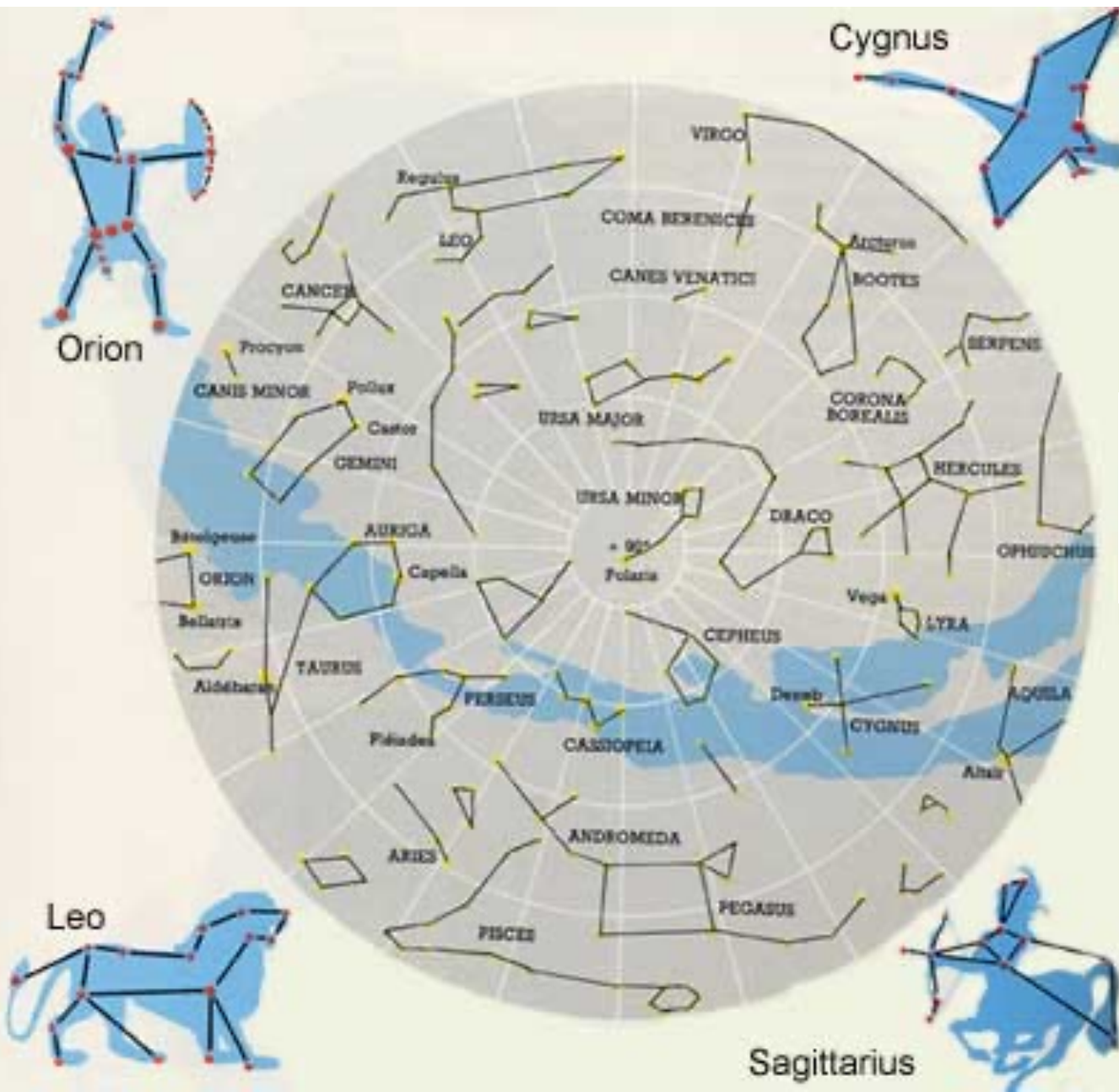

**Constellations:  
are the patterns  
right or wrong?**

# We can make our own Constellations

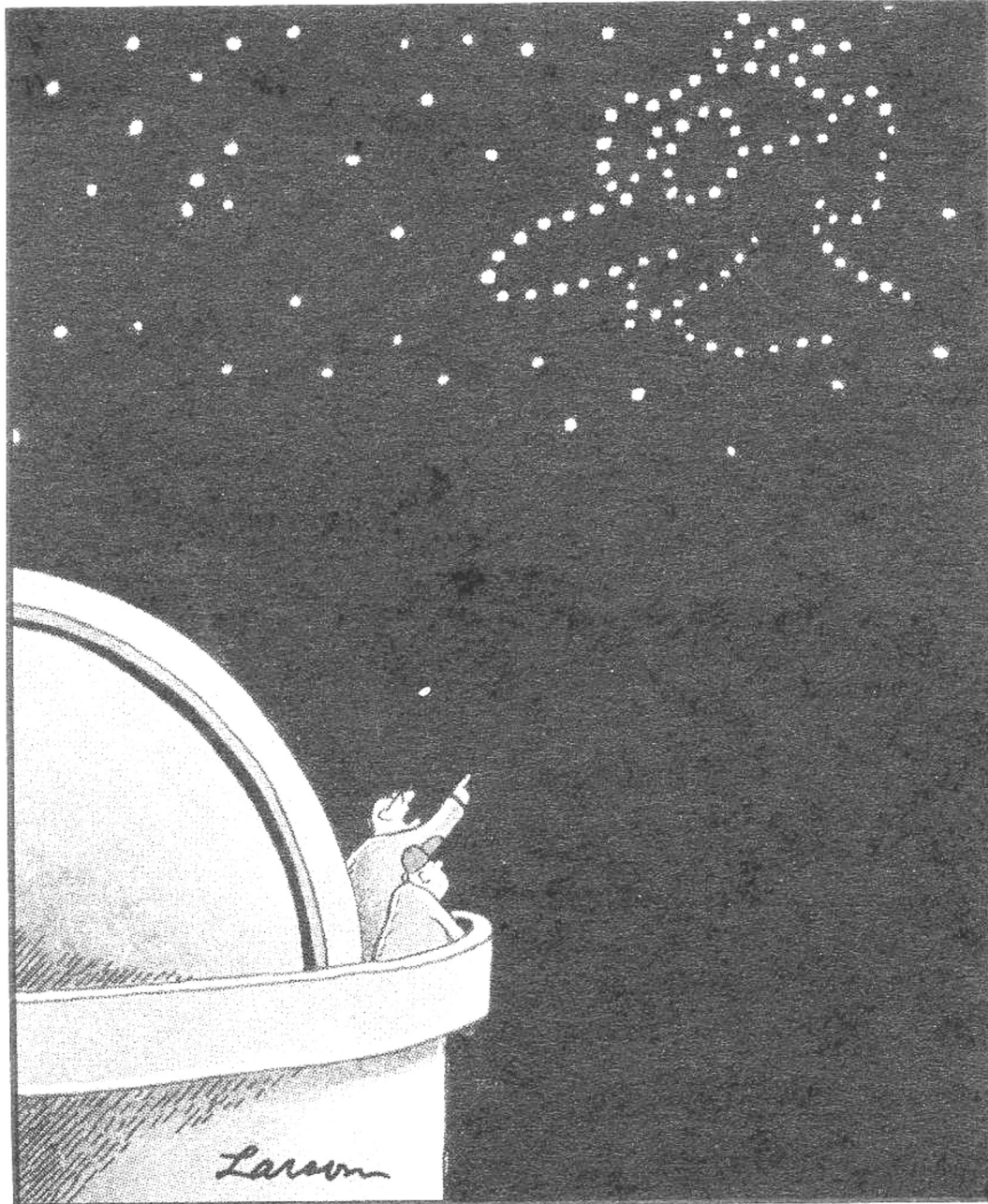

**“Now that  
constellation,  
Jimmy,  
is simply called  
‘The Big Dip!’”**

# The Farnese Atlas of the Heavens



**The “lost” star atlas of Hipparchus (ca 125 BC)**

# Precession of the Equinoxes

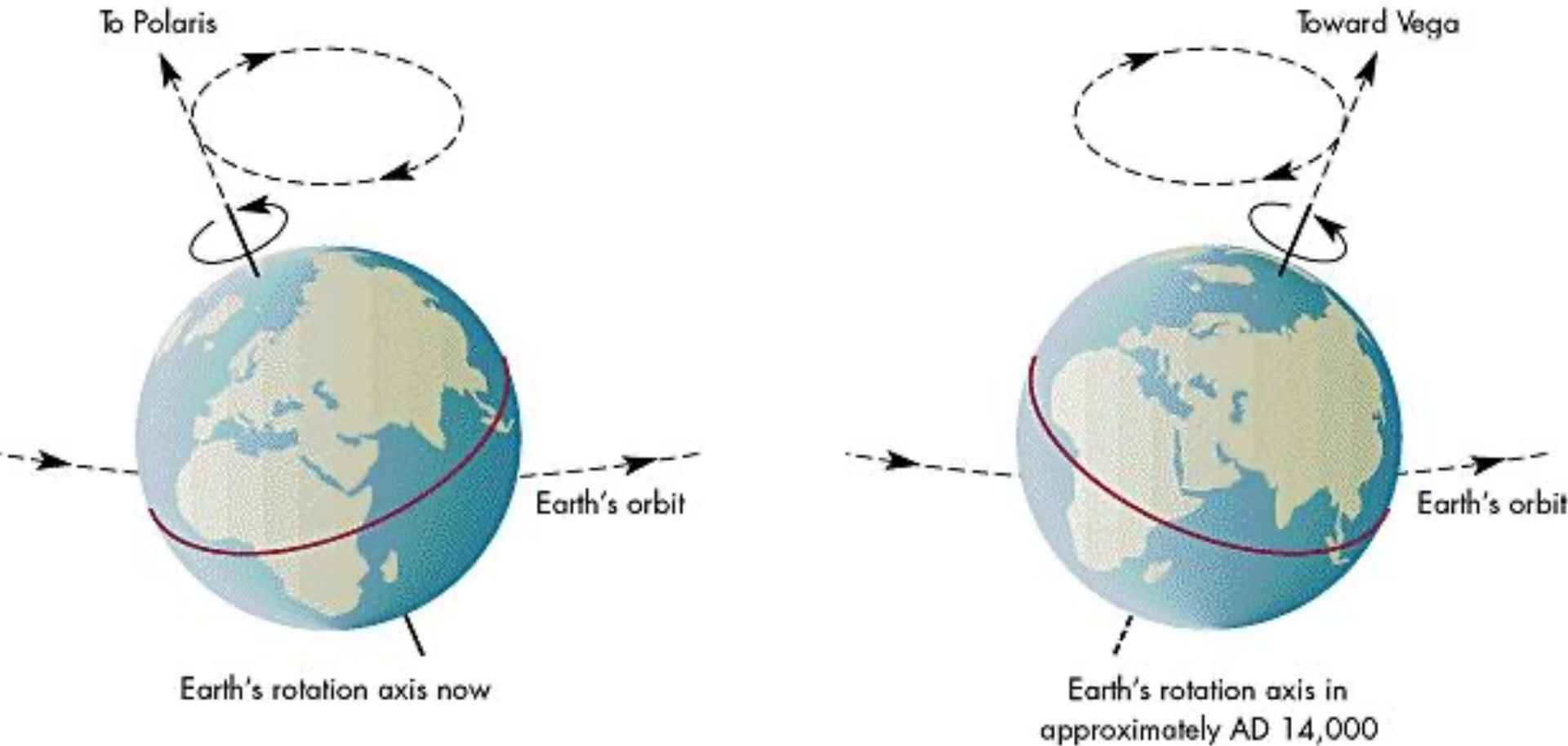

**Hipparchus also discovered this minute movement --  
By continual close examination of the pattern!**

# Using Patterns to Guide Us

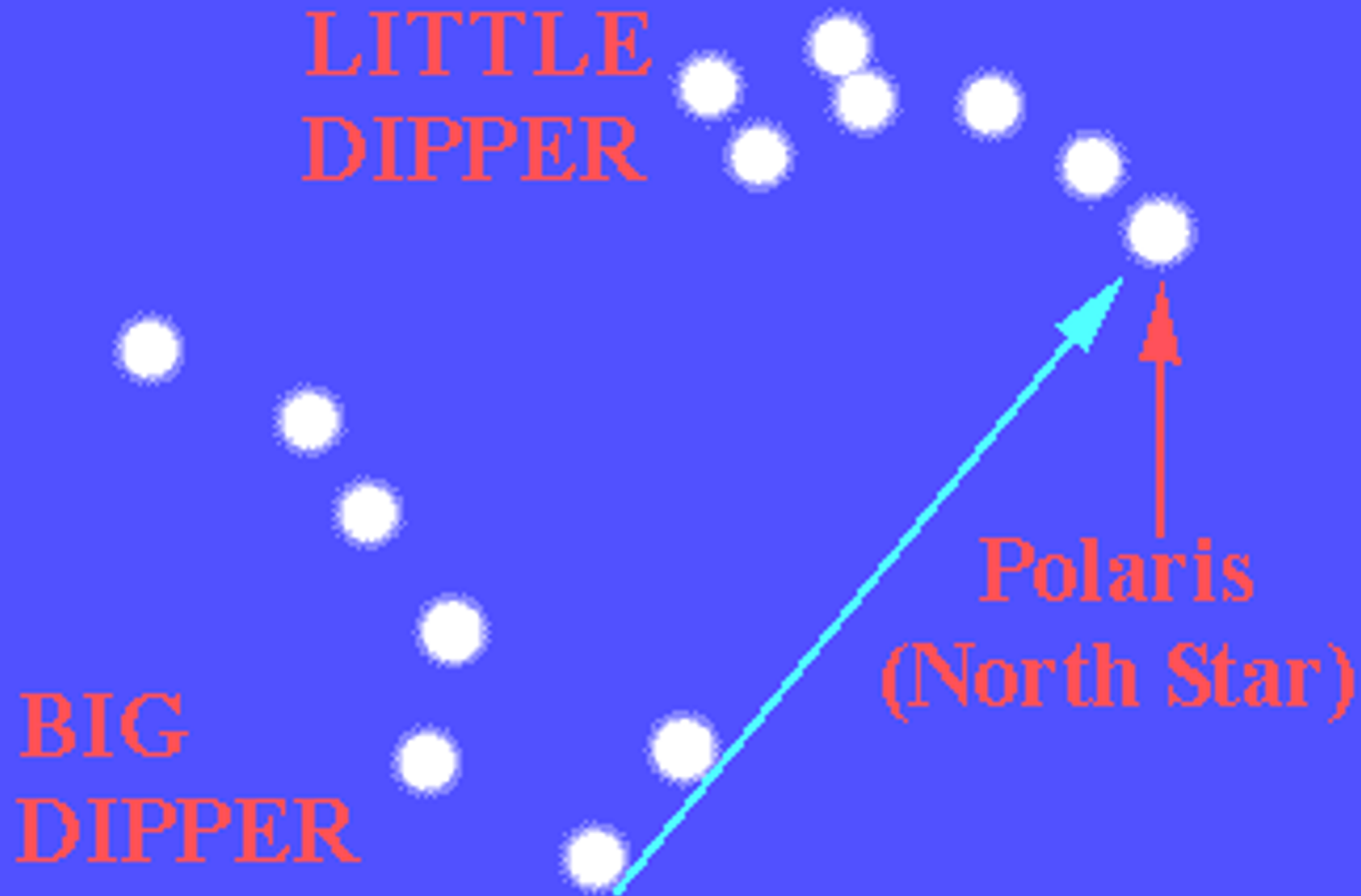

Constellations: helping us find a guide star

# Have you ever helped someone lost?

24



**Online with Mapquest!**

# Are signs always accurate?



**Some people like to change the signs to mess others up.**



# Structured city roads or unique landscaping? 24

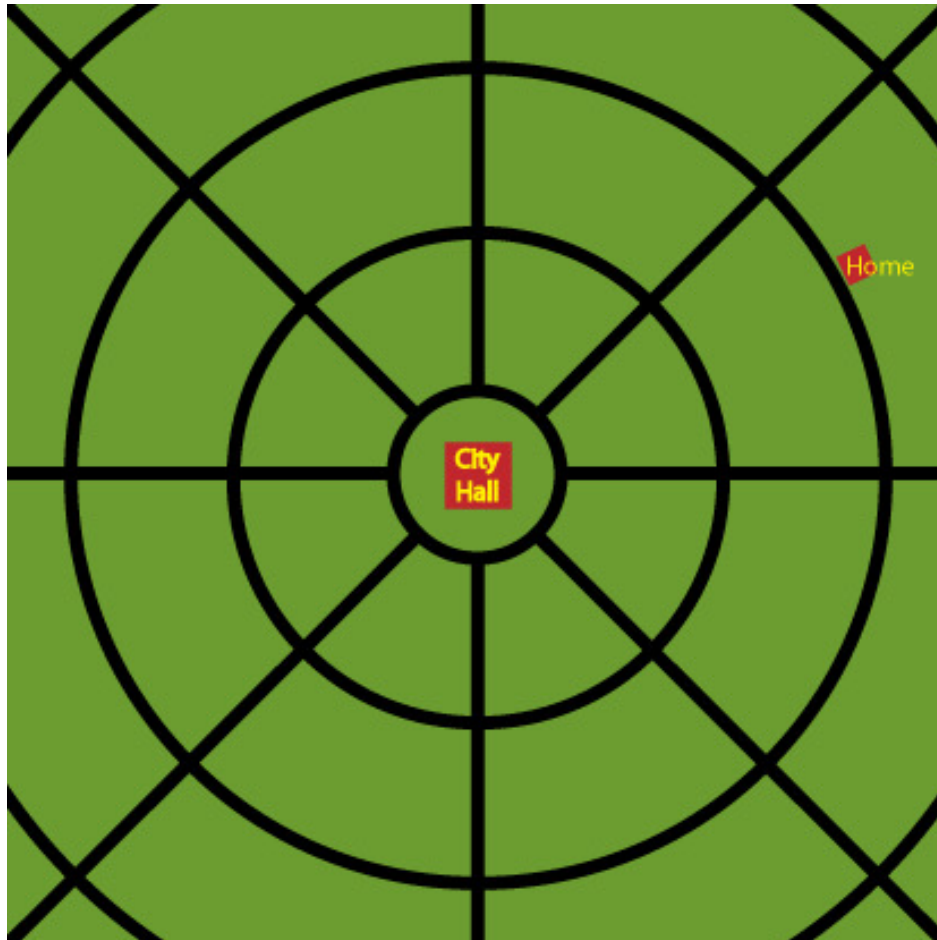
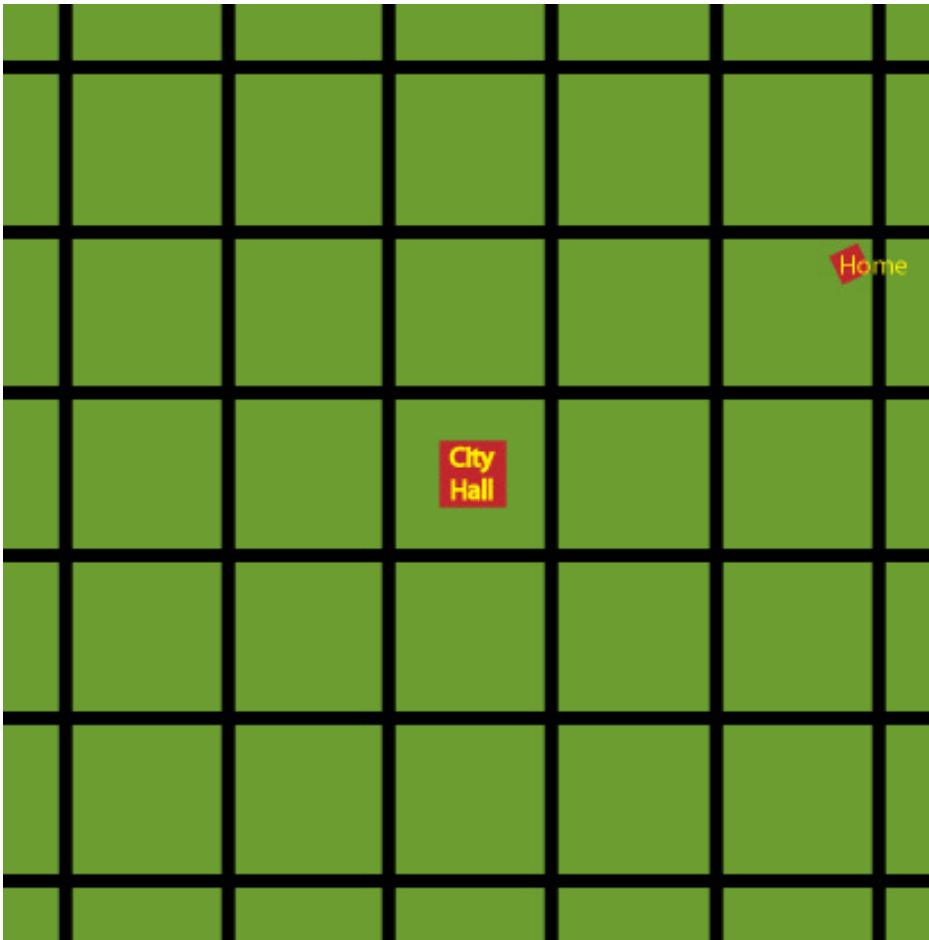

**Roads help when you don't know the way;  
they help keep things organized.**

# Most cities have to plan around landmarks

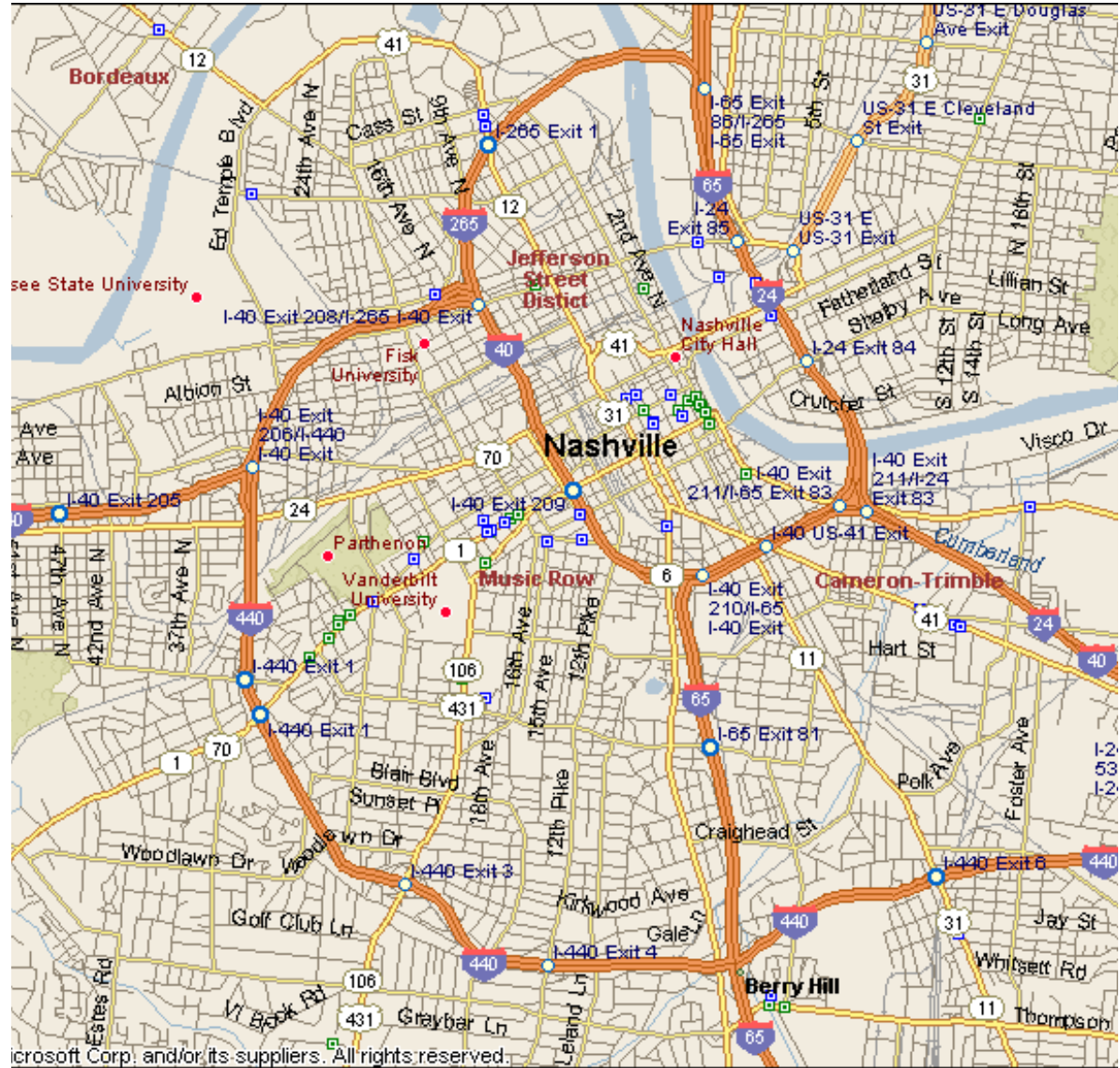

Should you let order or beauty guide you?

# Christ is the Way (the Pattern) to Follow

**Jesus answered,**

**"I am the **way** and the truth and the life.**

**No one comes to the Father except through me.**

**If you really knew me,**

**you would know my Father as well.**

**From now on, you do know him and have seen him."**

**John 14:6-7**

**I will put my law in their minds and write it on their hearts.**

**I will be their God, and they will be my people.**

**Jeremiah 31:33b**

**Do you have to keep checking the map,**

**or do you have the way written on your heart?**

## **Is there a time we should cut our own trail?**

**I want people who will come if there is no road at all.**

**David Livingstone**

**Don't go beyond what is written.**

**1 Corinthians 4:6**

**We are taught to stay within the lines when we are small,  
but then we need to express what is beautiful to us.**

**Is this getting off of the trail?**

**Sometimes bad things happen,  
but sometimes you see a breathtakingly beautiful place.**

**Not meaning to depart from Christ's Way,  
but to get out of the rut that makes us always do things  
the same way.**

# David's directional adventures

- **Which way is north?**
  - **Compass in watch in truck**
  - **State line**
  - **Bermuda triangle**
- Others...**

# The most important use is communication

The development of a written language is critical to us!

**Egyptian**  
3500 B.C.



**Hebrew**  
1500 B.C.



**Phoenician**  
1000 B.C.



**letter  
shapes  
are based  
on  
patterns**

**Greek**  
600 B.C.



**Roman**  
114 A.D.



A large, bold, black calligraphic character representing the Chinese word for 'Life' (生). The character is written in a traditional style with thick, expressive strokes. It features a vertical stem with three horizontal bars, a diagonal stroke on the left, and a wide, flat base.

Life

A large, bold, black calligraphic character representing the Chinese word for 'Death' (死). The character is written in a traditional style with thick, expressive strokes. It features a horizontal top bar, a diagonal stroke on the left, and a large, curved stroke on the right that ends in a hook.

Death

Something that looks beautiful may have a bad meaning

# Communication also occurs in sequence patterns<sup>25</sup>

Simpler languages must be used in less complex media

A: ·—	B: —···	C: —···
D: —··	E: ···	F: ····
G: —···	H: ····	I: ···
J: ·—···	K: —···	L: ····
M: —··	N: ···	O: —···
P: ·—···	Q: —····	R: ····
S: ···	T: —··	U: ····
V: ····	W: ·—··	X: —···
Y: —····	Z: —····	

Morse code is based on dots and dashes



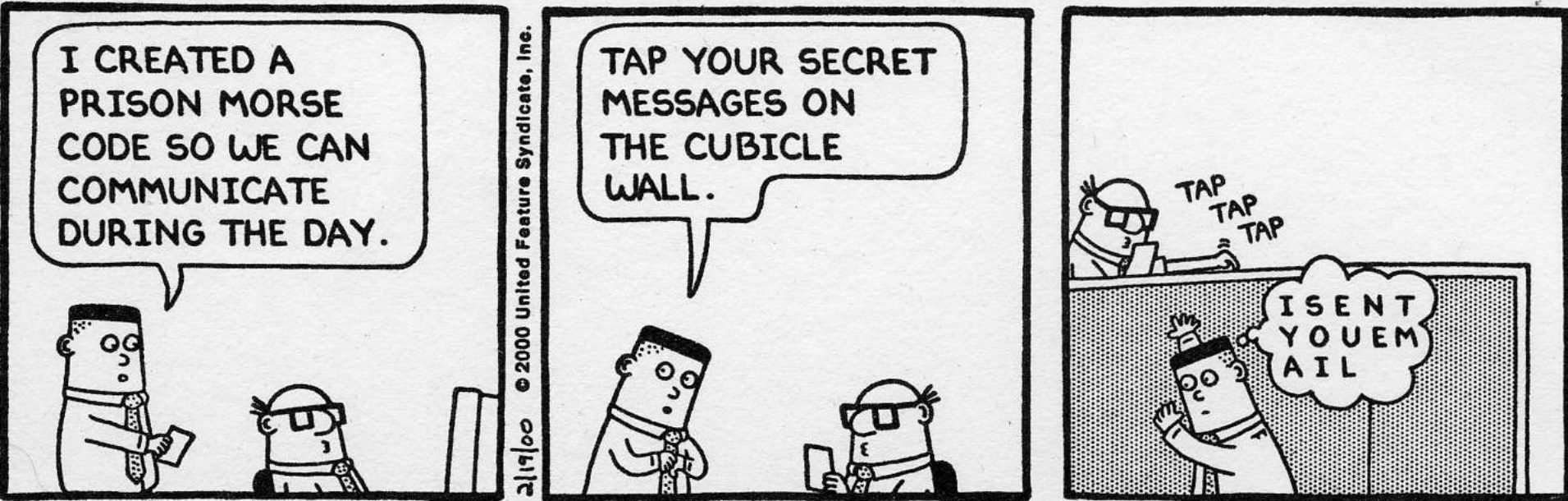

# Does anybody really know what time it is?



**Analog --> needs more interpretation**

# Different Levels of Meaning and Feeling

Music communicates in sequences, periods, and tones

V



Morse code



Beethoven's Fifth Symphony



WW II symbol for victory

Look at the different levels for a simple sequence pattern

# Uncertain Communication

**Even in the case of lifeless things that make sounds,  
such as the flute or harp,  
how will anyone know what tune is being played  
unless there is a distinction in the notes?**

**Again, if the trumpet does not sound a clear call,  
who will get ready for battle?**

**So it is with you.**

**Unless you speak intelligible words with your tongue,  
how will anyone know what you are saying?**

**You will just be speaking into the air.**

**1 Corinthians 4:7-9**

**We must make sure we reflect Christ accurately**

# How well can you spell?



“Wait! Wait! ... Cancel that, I guess it says ‘help.’”

# Orienting the Pattern (or map) is important



“Well, I’ll be. ... I must’ve been holding the dang work order like *this!*”

# Building for Strength follows a Pattern

**Altars had to be built to hold the fire and the sacrifice**



# **Building an altar after crossing the Jordan (1)**

**When you have crossed the Jordan  
into the land the LORD your God is giving you,  
set up some large stones and coat them with plaster.**

**Write on them all the words of this law  
when you have crossed over  
to enter the land the LORD your God is giving you**

**Deuteronomy 27:2-3**



# Building an altar after crossing the Jordan (1)

**When the whole nation had finished crossing the Jordan,  
the LORD said to Joshua,**

**"Choose twelve men from among the people,  
one from each tribe,  
and tell them to take up twelve stones  
from the middle of the Jordan  
from right where the priests stood  
and to carry them over with you  
and put them down  
at the place where you stay tonight."**

**Joshua 4:1-3**

# Repairing the altar of the Lord

**Then Elijah... repaired the altar of the LORD,  
which was in ruins.**

**Elijah took twelve stones,  
one for each of the tribes descended from Jacob,  
to whom the word of the LORD had come, saying,  
"Your name shall be Israel."**

**With the stones he built an altar in the name of the LORD**

**1 Kings 18:30-32**

**It was built strong, but not kept up; it fell into disuse.**

# Overlaying Stones for Strength

**How do you fit differently shaped stones  
in a productive pattern that yields strength?**

**How do you pack your luggage into the trunk of a car?**

**We must put big (higher priority) items in first.**



# Solomon's Temple was Built to Last

26

But God had other plans



# Even the incredible temple building was destroyed<sup>26</sup>

**Some of his disciples were remarking about how the temple was adorned with beautiful stones and with gifts dedicated to God.**

**But Jesus said,**

**"As for what you see here,  
the time will come  
when not one stone will be left on another;  
every one of them will be thrown down."**

**Luke 21:5-6**

**All that is left is the Western "Wailing" Wall**

# The Walls around Jerusalem protected the People<sup>26</sup>

**Nehemiah went back to the promised land from captivity to rebuild the walls of Jerusalem.**

**God blessed Him and gave the city another chance.**



**No man-made fortress is eternal**

# Appearances can be deceiving

Rock wall can tumble,  
but a paper arch can  
support a huge load.

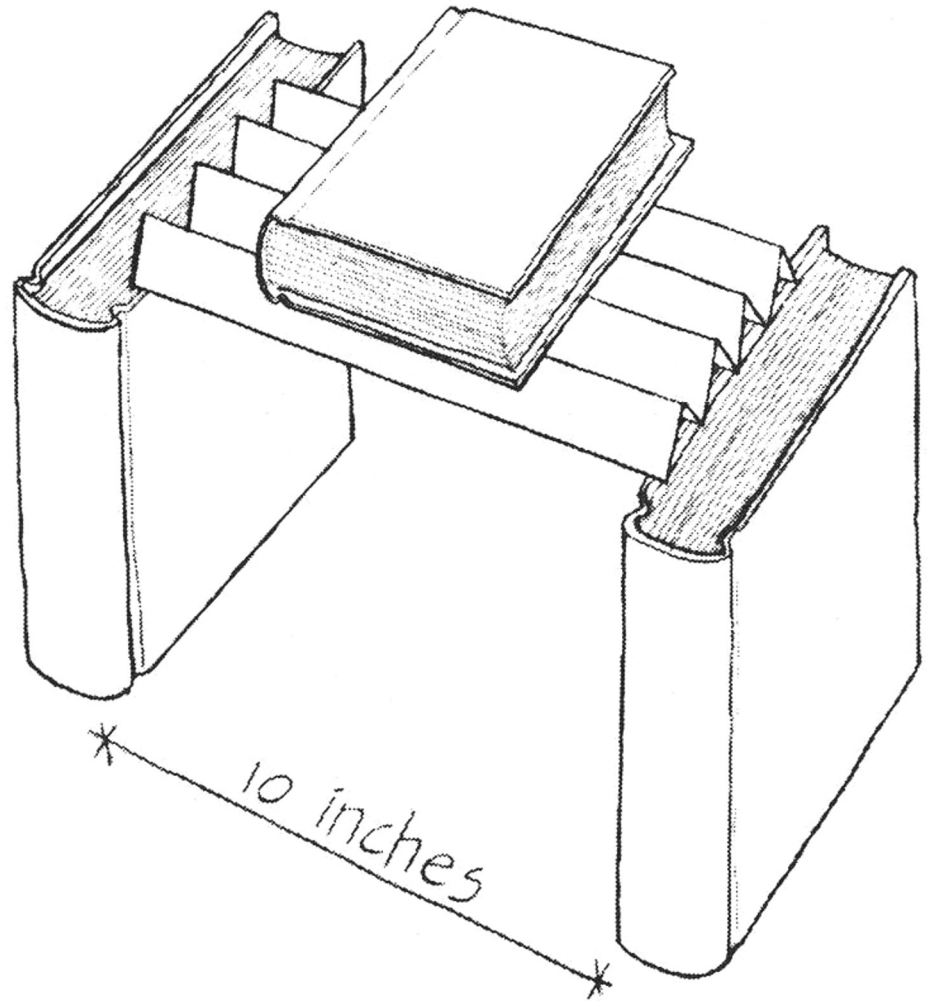
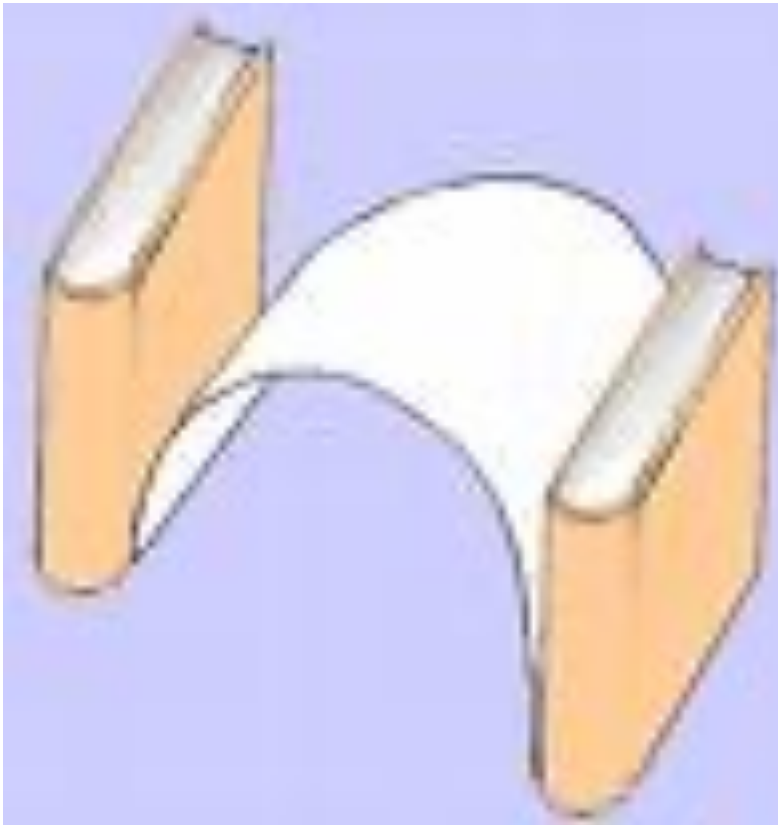

We are weak, but God can make us strong

# Strength out of Weakness

**He gives strength to the weary  
and increases the power of the weak.**

**Isaiah 40:29**

**I can do everything through him who gives me strength.**

**Philippians 4:13**

**But he said to me,**

**"My grace is sufficient for you,  
for my power is made perfect in weakness."**

**Therefore I will boast all the more gladly  
about my weaknesses,  
so that Christ's power may rest on me.**

**2 Corinthians 12:9**



# **The Inner Structure is the true Strength not the outer appearance**

**A man is not a Jew if he is only one outwardly,  
nor is circumcision merely outward and physical.**

**No, a man is a Jew if he is one inwardly;  
and circumcision is circumcision of the heart,  
by the Spirit, not by the written code.**

**Romans 2:28-29**

# **The internal structure cannot be patched from the outside**

**No one sews a patch of unshrunk cloth  
on an old garment,  
for the patch will pull away from the garment,  
making the tear worse.**

**Matthew 9:16**

**Trying to fit the “external” pattern is not enough;  
it doesn’t reflect true transformation.**

# **The internal structure cannot be patched from the outside**

**Woe to you, teachers of the law and Pharisees,  
you hypocrites!**

**You are like whitewashed tombs,  
which look beautiful on the outside  
but on the inside are full of dead men's bones  
and everything unclean.**

**Matthew 23:27**

**We must make changes deep within us**

# Sometimes the Structure is Limiting

**Our fundamental structure must be able to grow**

**Neither do men pour new wine into old wineskins.**

**If they do, the skins will burst,**

**the wine will run out and the wineskins will be ruined.**

**No, they pour new wine into new wineskins,**

**and both are preserved.”**

**Matthew 9:17-18**

**We need to be building a structure**

**to hold, retain, sustain God's Goodness**

# God has the Power to Expand our Minds and Hearts

**A mind stretched by a new idea  
can never go back to its original dimensions.**

**Oliver Wendell Holmes, Jr.**

**But we must allow for flexibility**

# Balance and Symmetry

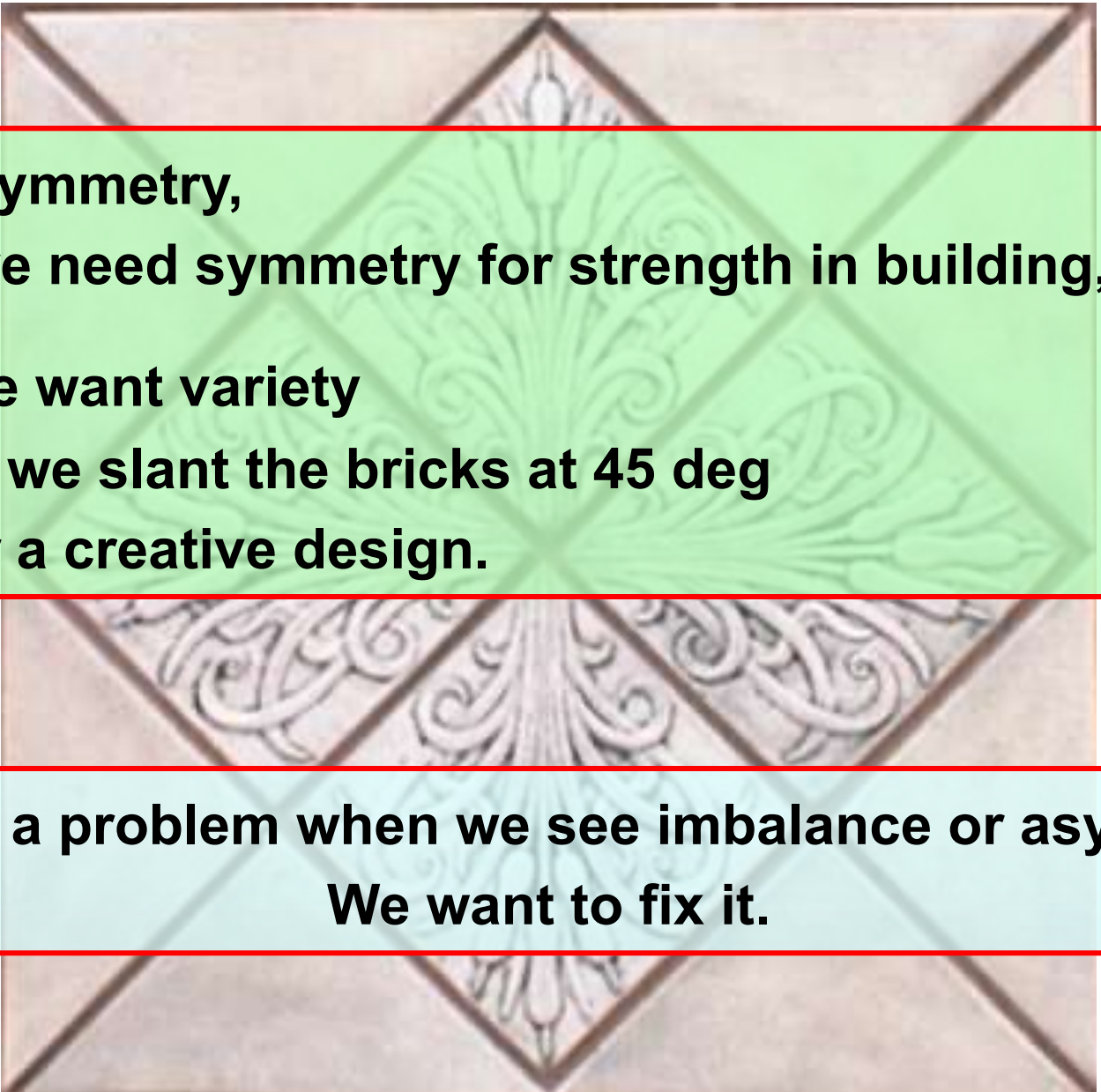

**We like symmetry,  
and we need symmetry for strength in building,  
but we want variety  
so we slant the bricks at 45 deg  
for a creative design.**

**We have a problem when we see imbalance or asymmetry.  
We want to fix it.**

# Balance (or lack thereof)

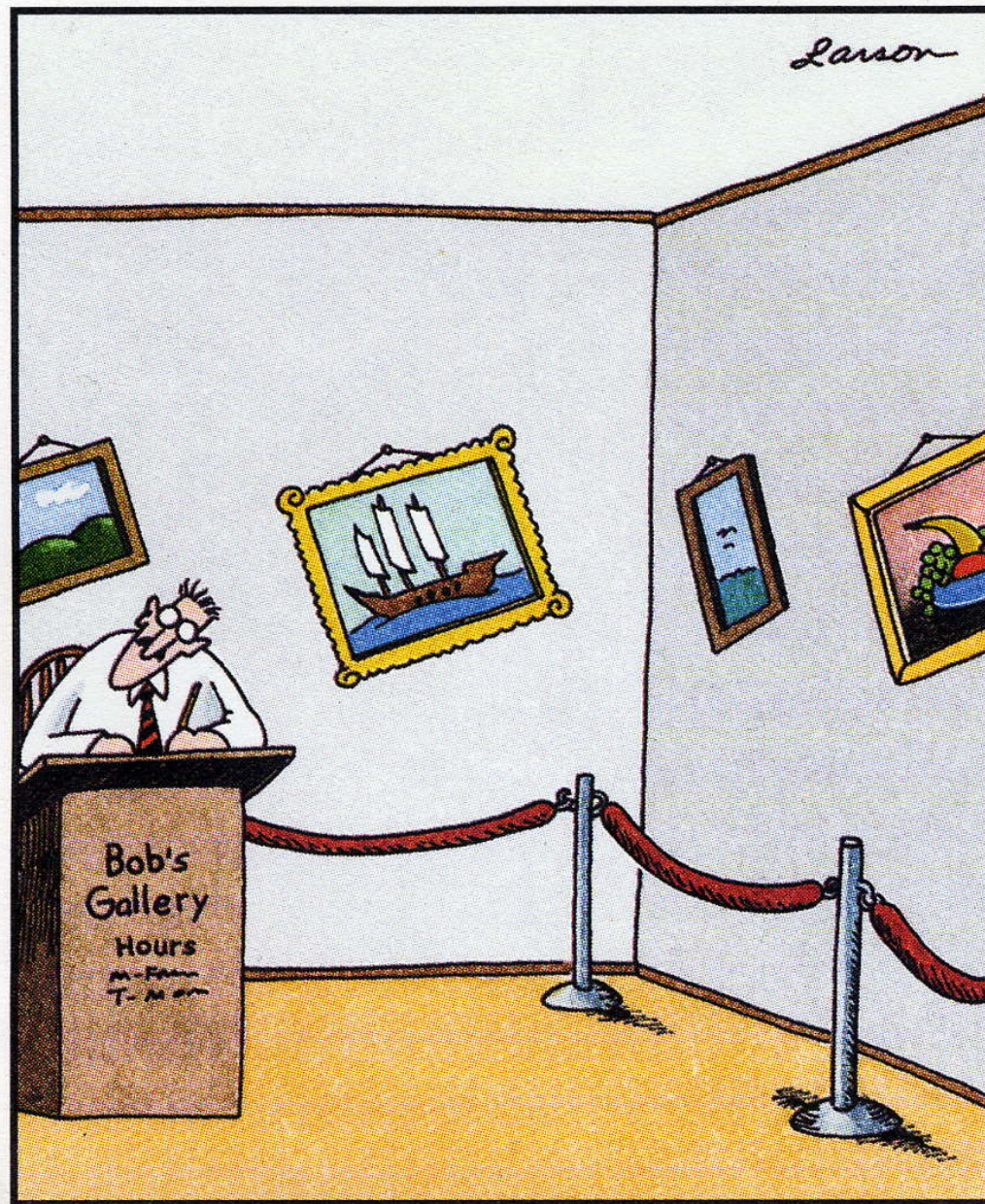

# Symmetry in the Auditorium

In the pattern of chairs in the auditorium...



Do feel lost when the pattern is changed?



# Symmetry at the Communion Table

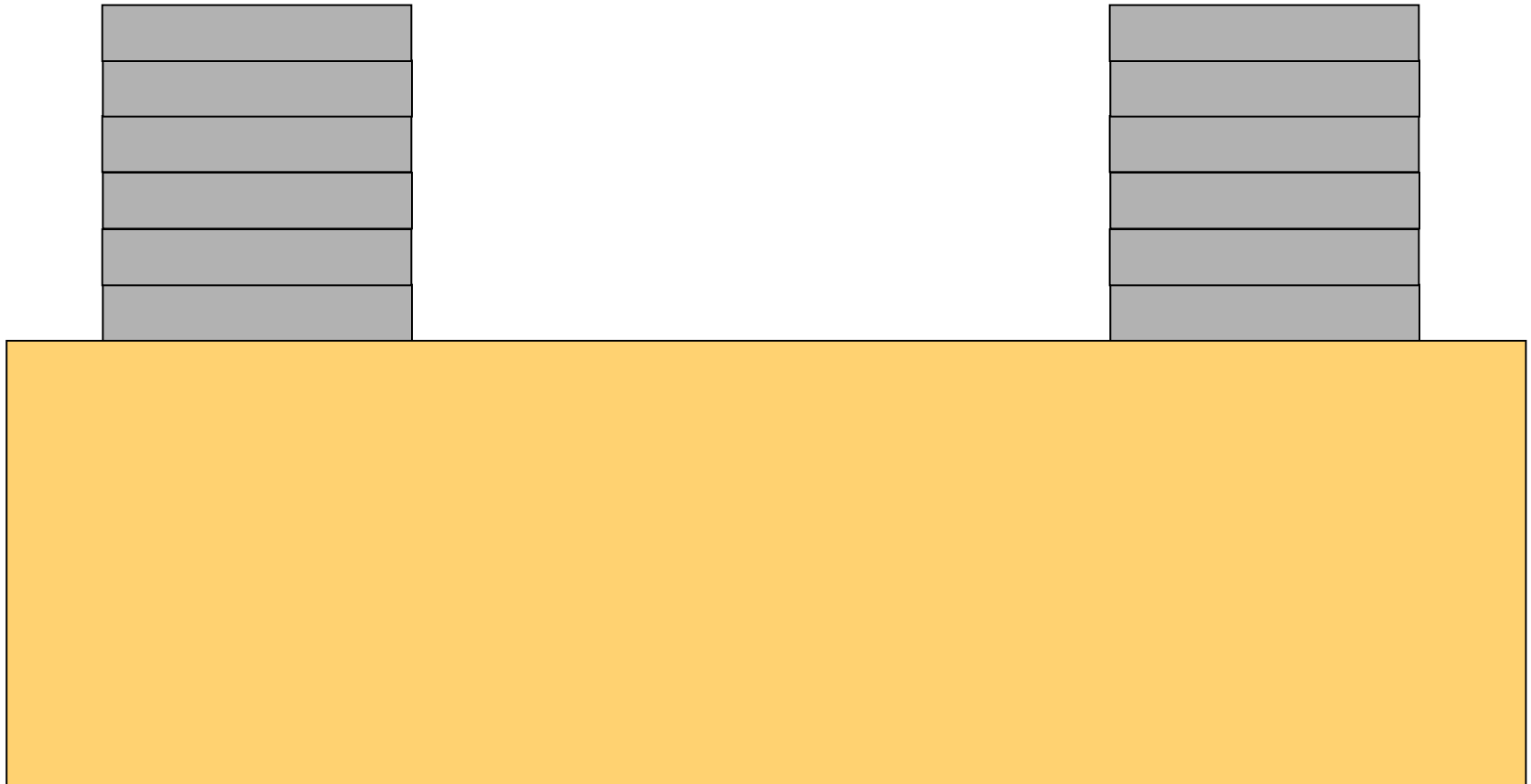

**We need to have order in our lives**

# Symmetry at the Communion Table (not)

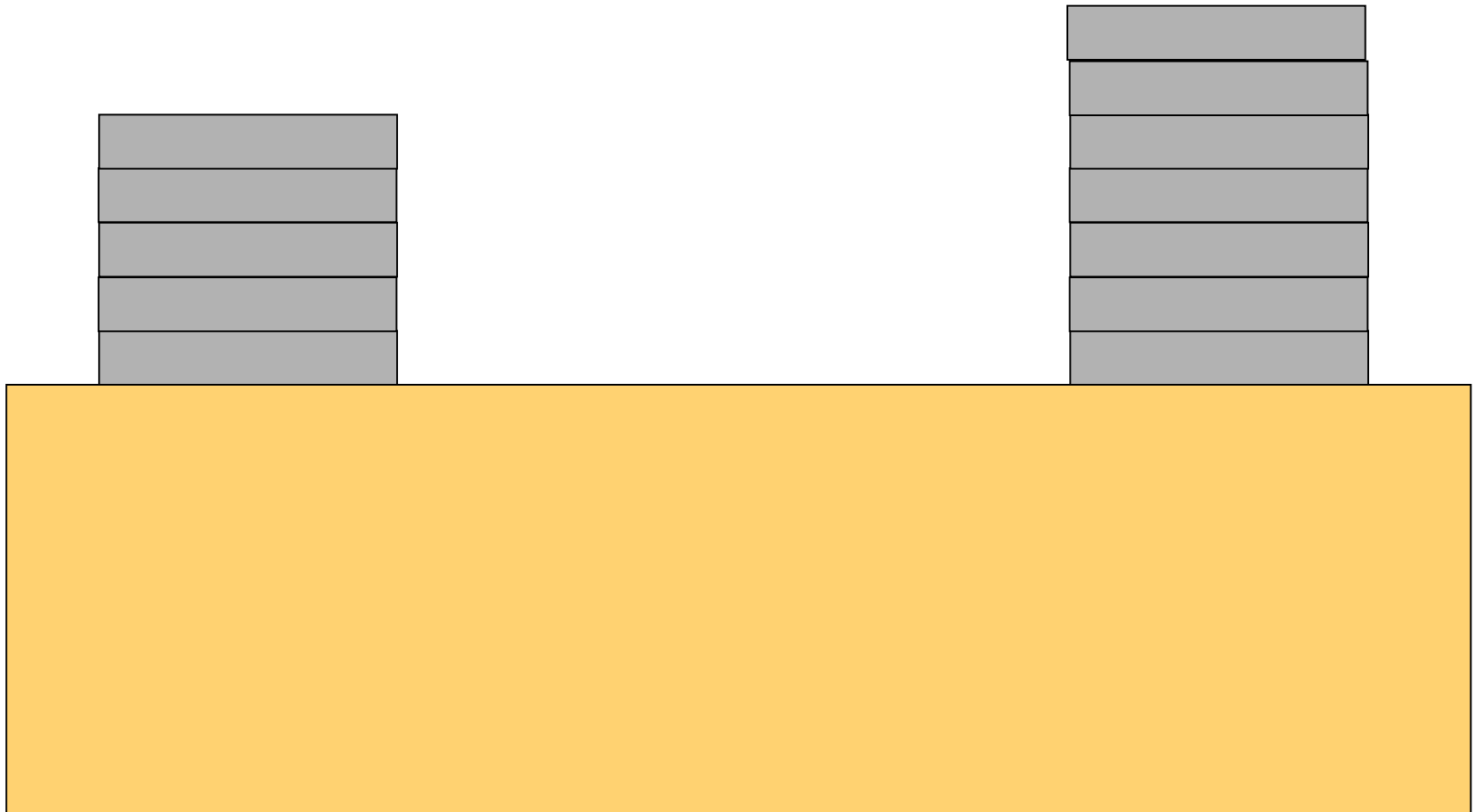

**Do feel a compulsion to balance it out?**

# The Pattern of the Apostles in The Last Supper <sup>27</sup>

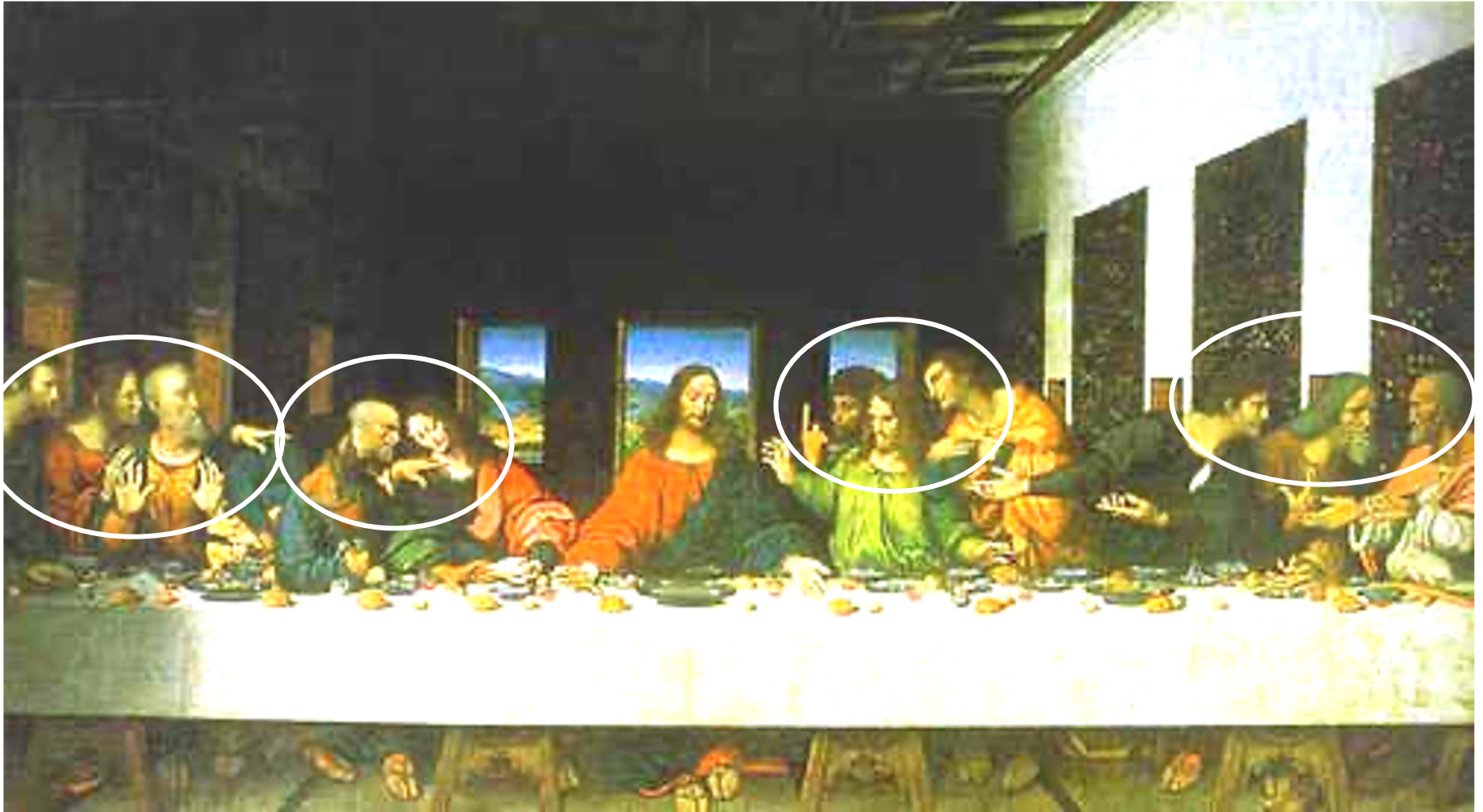

**Leonardo da Vinci inserted his own symmetry into this, one of the world's best known paintings.**

# There must be a balance in the body of Christ (1)<sup>27</sup>

Instead, speaking the truth in love,  
we will in all things  
grow up into him who is the Head,  
that is, Christ.

From him the whole body,  
joined and held together  
by every supporting ligament,  
grows and builds itself up in love,  
as each **part** does its work.

**Ephesians 4:15-16**

# There must be a balance in the body of Christ (2)<sup>27</sup>

Now the body is not made up of one part but of many.

If the foot should say,

"Because I am not a hand, I do not belong to the body,"  
it would not for that reason cease to be **part** of the body.

And if the ear should say,

"Because I am not an eye, I do not belong to the body,"  
it would not for that reason cease to be **part** of the body.

If the whole body were an eye,  
where would the sense of hearing be?

If the whole body were an ear,  
where would the sense of smell be?

But in fact God has arranged the **parts** in the body,  
every one of them, just as he wanted them to be.

If they were all one **part**, where would the body be?

As it is, there are many **parts**, but one body.

1 Corinthians 12:14-20

# There must be a balance in the body of Christ (3)<sup>7</sup>

The eye cannot say to the hand, "I don't need you!"  
And the head cannot say to the feet, "I don't need you!"

On the contrary, those **parts** of the body  
that seem to be weaker are indispensable,  
and the **parts** that we think are less honorable  
we treat with special honor.

And the parts that are unpresentable  
are treated with special modesty,  
while our presentable **parts** need no special treatment.

But God has combined the members of the body  
and has given greater honor to the **parts** that lacked it,  
so that there should be no division in the body,  
but that its **parts** should have equal concern for each other.

If one **part** suffers, every part suffers with it;

if one **part** is honored, every **part** rejoices with it.

Ephesians 4:15-16

# **There must be a balance in the body of Christ (4)<sup>27</sup>**

**Some people are the left-handed parts;  
not as coordinated,  
but they are still part of the body.**

**If you bought it (your body) at Sears,  
you'd take it back!**

**Gallagher**

# Seeing Angels in Tomatoes





# You can make something out of anything!

This is the Coca Cola Logo.



● Now if we flip it horizontally



● It would look like this, right?  
Now watch carefully as I  
adjust the image a little

1.

2.

● Now if you  
can read any  
Arabic, you can tell  
what it is saying can't you. If  
not, then here it is in Arabic.

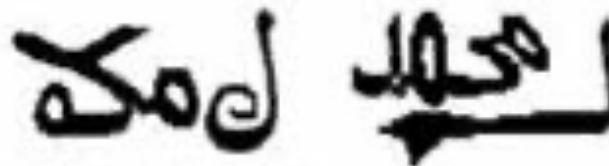

Which Means:  
NO MUHAMMAD  
NO MAKKAH

Some Arabs are upset, believing this is intentional.

# Twisted Cord Illusion

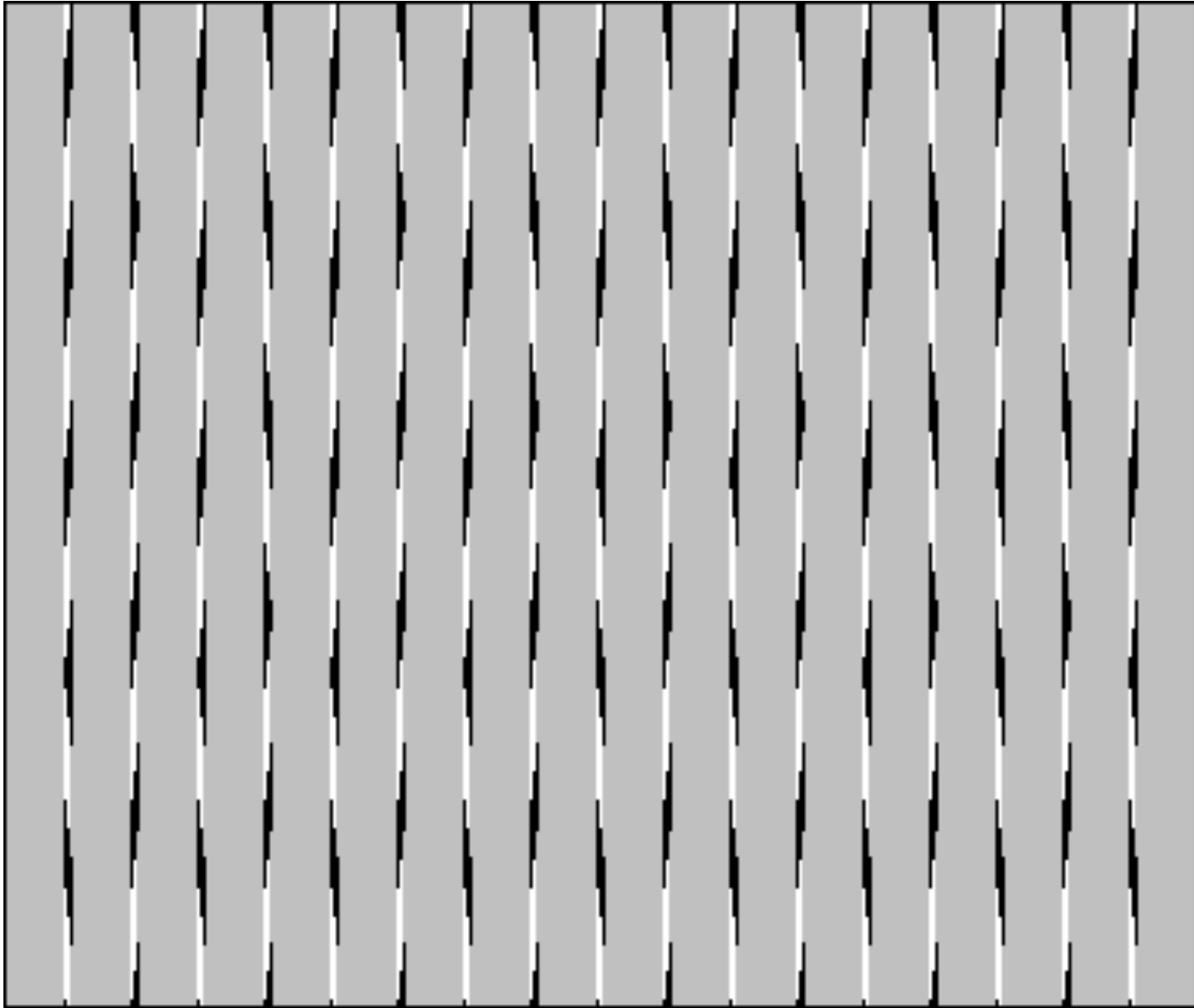

**Rules are meant to be straight. Have we twisted them?**

# Outline of the Class

- Introduction
- The Perception Process
- Pattern Structure
- **The Pattern of God's Plan**
- **Critical Patterns**
  - Law
  - Church
  - Family
  - God's Goodness
  - Personal
- **Developing the Pattern God Wants in Us**
- **Summary**

# The Pattern of God's Plan (1)

God has given us the pattern that he wants us to follow.

It is so important to determine what is the basis, or the foundation of our spiritual life.

We need to think about the core of our belief, which begins with the Jewish heritage that we are all so familiar with.

The first level is the ten commandments that God delivered to His people through Moses.

The Israelites revered these statutes, and thought of them as the ultimate set of rules for their behavior.

Another rule that was considered as representative of the will of the God of the Old Testament concerns justice: that of an eye for an eye and a tooth for a tooth.

People use that to exact revenge on those who have slighted them, and this was not God's intent.

# The Pattern of God's Plan (2)

God wanted man to see what was most important.

These two basic groups of principles, were the driving force behind the Jewish interpretation of their religion.

There was much more attention paid to rules than principles, and there is a huge difference between them.

There was no mention of love in either.

One scripture that was a highlight and sacred to many is the **Shema**, which speaks of loving God with every fiber of our being.

In the Old Testament God wants people to love each other, but this is not really paid attention to.

He makes it very clear that there is a great contrast between Good and Evil, and there is only one choice for us.

# Hate Evil, Love Good

Turn from evil and **do good**; seek peace and pursue it.

**Psalms 34:14**

Turn from evil and **do good**; then you will dwell in the land forever.

**Psalms 37:27**

You love evil rather than good, falsehood rather than speaking the truth.

**Psalms 52:3**

**Seek good, not evil**, that you may live.

Then the LORD God Almighty will be with you, just as you say he is.

**Hate evil, love good...**

**Amos 5:14-15**

Love must be sincere. **Hate what is evil; cling to what is good.**

**Romans 12:9**

# Love is Supreme

**Love must be the glue  
that binds everything together.**

**Surface appearance  
(keeping the law)**

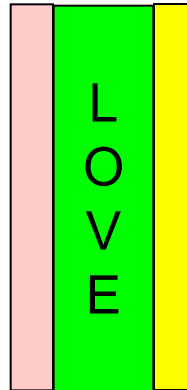

**Reality of the heart  
(meaning)**

# Building the Pattern of Truth

the Shema

an eye for an eye...

love good, hate evil

the Ten Commandments



# Building the Pattern of Truth

It is clear that the concept of love formed a critical part of God's plan for man as revealed in the Old Testament, even though it wasn't embraced by the people.

Did the Ten Commandments produce Love?

---

the Shema

love good, hate evil

an eye for an eye...

the Ten Commandments

# The Pattern of God's Plan (6)

**Jesus contrasts God's pattern to that of the Pharisees.**

Jesus confronts this conventional wisdom in the sermon on the mount, when he repeats the phrase, "You have heard that it was said... but I tell you".

This type of language is found only in Matthew 5.

First Jesus responds with an introductory passage that emphasizes Christ's commitment to God's plan as expressed in the law and the prophets.

But He begins this passage of contrast by claiming that the righteousness of the so-called religious leaders is seriously lacking, and not sufficient to be pleasing to God.

# Preface to the Sermon on the Mount

**"Do not think that I have come to abolish the Law or the Prophets; I have not come to abolish them but to fulfill them.**

**I tell you the truth, until heaven and earth disappear, not the smallest letter, not the least stroke of a pen, will by any means disappear from the Law until everything is accomplished.**

**Anyone who breaks one of the least of these commandments and teaches others to do the same will be called least in the kingdom of heaven, but whoever practices and teaches these commands will be called great in the kingdom of heaven.**

**For I tell you that unless your righteousness surpasses that of the Pharisees and the teachers of the law, you will certainly not enter the kingdom of heaven.**

**Matthew 5:17-20**

**Is this a new pattern?**

**Is Christ changing the pattern --  
or using it as a foundation to build on?**

# Building the Pattern of Truth

Jesus works to break the dependence of the people on the old way of thinking;

He tries to shift their perspective and shake up their mindset in the following verses.

He illustrates his point by contrasting views on several of the ten commandments to the common interpretation (the old, underlying pattern).

**conventional wisdom**  
("you have heard it said")  
**Jesus interprets**

the Shema

an eye for an eye...

love good, hate evil

the Ten Commandments

# You have heard it said... (Murder)

**"You have heard that it was said to the people long ago, 'Do not murder, and anyone who murders will be subject to judgment.'**

**But I tell you that anyone who is angry with his brother will be subject to judgment.**

Jesus shows the true intent: do not hate someone enough to demean them

**Again, anyone who says to his brother, 'Raca, ' is answerable to the Sanhedrin. But anyone who says, 'You fool!' will be in danger of the fire of hell.**

**"Therefore, if you are offering your gift at the altar and there remember that your brother has something against you, leave your gift there in front of the altar. First go and be reconciled to your brother; then come and offer your gift.**

**"Settle matters quickly with your adversary who is taking you to court. Do it while you are still with him on the way, or he may hand you over to the judge, and the judge may hand you over to the officer, and you may be thrown into prison.**

**I tell you the truth, you will not get out until you have paid the last penny.**

**Matthew 5:21-26**

# You have heard it said... (Adultery)

**"You have heard that it was said, 'Do not commit adultery.'**

**But I tell you** that anyone who looks at a woman lustfully has already committed adultery with her in his heart.

If your right eye causes you to sin, gouge it out and throw it away. It is better for you to lose one part of your body than for your whole body to be thrown into hell.

And if your right hand causes you to sin, cut it off and throw it away. It is better for you to lose one part of your body than for your whole body to go into hell.

**"It has been said,** 'Anyone who divorces his wife must give her a certificate of divorce.'

**But I tell you** that anyone who divorces his wife, except for marital unfaithfulness, causes her to become an adulteress, and anyone who marries the divorced woman commits adultery.

**Matthew 5:27-32**

# Recognition - AHA! or Eureka!

Legend has it that Archimedes was just about to step into his bath when the light went off over his head.

He had been ordered by his king, Hiero, to find out if his crown was pure gold without destroying it.

Archimedes noticed that the water rose in his bath as he stepped in, and the insight struck. The displacement of the water was directly related to the volume of whatever was put into the tub, even his foot, so all he had to do was submerge the crown in water to determine its purity.

And, as legend has it, Archimedes was so thrilled he shouted "Eureka," (I have found it) and ran home through the streets of ancient Greece without bothering to put on his toga.

**Do you have the AHA! experience very often?**

**Does it happen to give you insight to the Pattern of God?**

# Recognition -- the “snap” of putting it together <sup>9</sup>

**At each perception of a concept,  
there is the “click” when realization occurs.**

**When we looking for something  
(how often do you lose things?),  
we scan objects for recognition;  
how does the brain “snap” when the object is found?**

**We get a good feeling  
when we are in tune with the pattern,  
or when we build according to the pattern.**

**We find it difficult to get computers to perform the  
pattern recognition that is performed routinely  
in our brains.**



# Recognition - Don't miss the point!

**What good is the most thrilling romance of a life,  
yea, what good will it do  
if my life has been successful in secondary things  
and men head carloads of wreaths upon my coffin,  
if a higher hand writes upon the margin of my life:  
  
'you missed the theme; you did not get the point'.**

**Helmut Thielicke**

# Recognition of Stick Figure

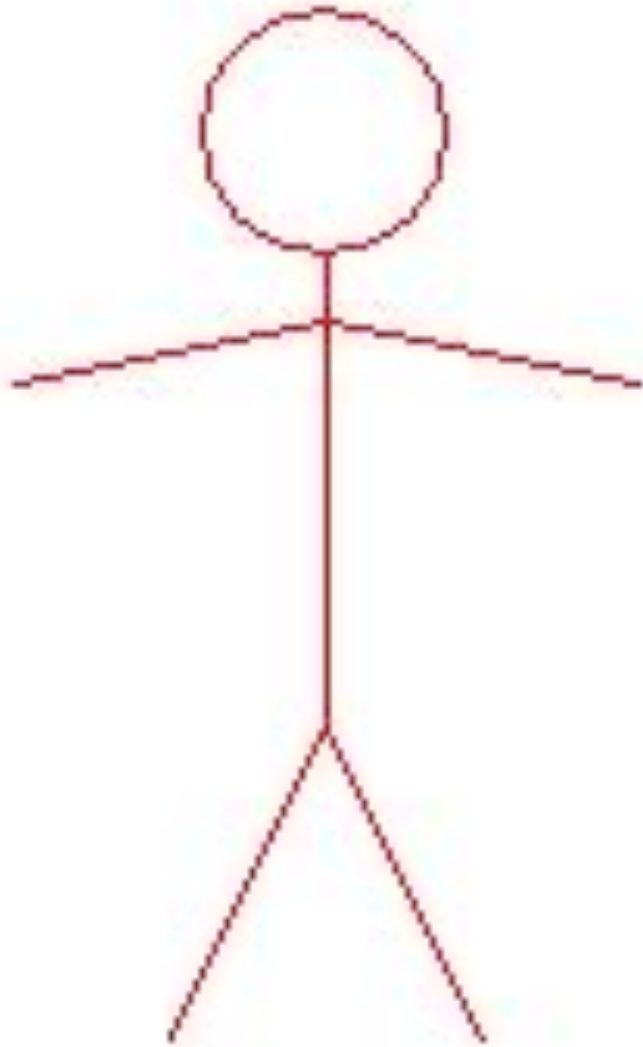

**How much do we need to recognize the form, or idea?**

# Recognition of Abstract Art

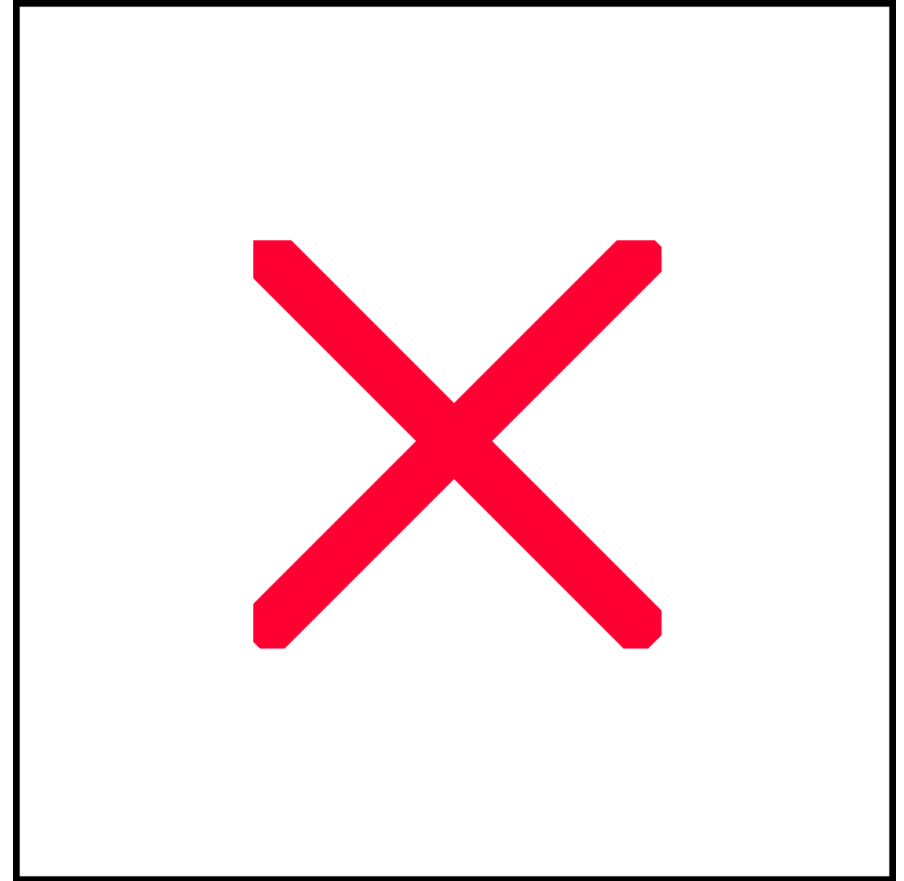

**Should we hang it horizontally or vertically?**

# Recognition of Abstract Art



Jackson Pollock makes a mistake

© Original Artist  
Reproduction rights obtainable from  
[www.CartoonStock.com](http://www.CartoonStock.com)

**How do know if it is wrong? Or if it is art?**

# **We must recognize the (hidden) face of God**

**He [Christ] cries...**

**If only I could make them see God as He really is:  
if only they could realize that He is their Father,  
that what their own child is to them,  
that, and far more,  
each of them is to Him.**

**A. J. Gossip**

**Next week we will look at recognizing faces.**

The link between the spiritual and the physical finds expression in the details of the biblical **Tabernacle** said to have accompanied the Israelites during their forty-year trek in the desert.

Gerald Schroeder

# The Pattern of God's Plan (1)

God has given us the pattern that he wants us to follow.

It is important to determine the basis of our spiritual life.

The core begins with our Jewish heritage.

The first level is the ten commandments, thought of by the Israelites as the ultimate set of rules for their behavior.

Local justice allowed an eye for an eye / a tooth for a tooth.

The most sacred scripture is the **Shema**,  
which speaks of loving God with every fiber of our being.  
And **we should love whatever God loves** (His creation).

God wants people to love each other, and to see  
the great contrast between Good and Evil.

Do we pay more attention paid to rules or principles?

# The Pattern of God's Plan (6)

**Jesus contrasts God's pattern to that of the Pharisees.**

Jesus confronts this conventional wisdom in the sermon on the mount, when he repeats the phrase, "You have heard that it was said... but I tell you".

This type of language is found only in Matthew 5.

First Jesus responds with an introductory passage that emphasizes Christ's commitment to God's plan as expressed in the law and the prophets.

But He begins this passage of contrast by claiming that the righteousness of the so-called religious leaders is seriously lacking, and not sufficient to be pleasing to God.



# Building the Pattern of Truth

## Re-interpretations:

Do not murder (Do not hate, but love)

Do not commit adultery (Do not lust; keep your commitments)

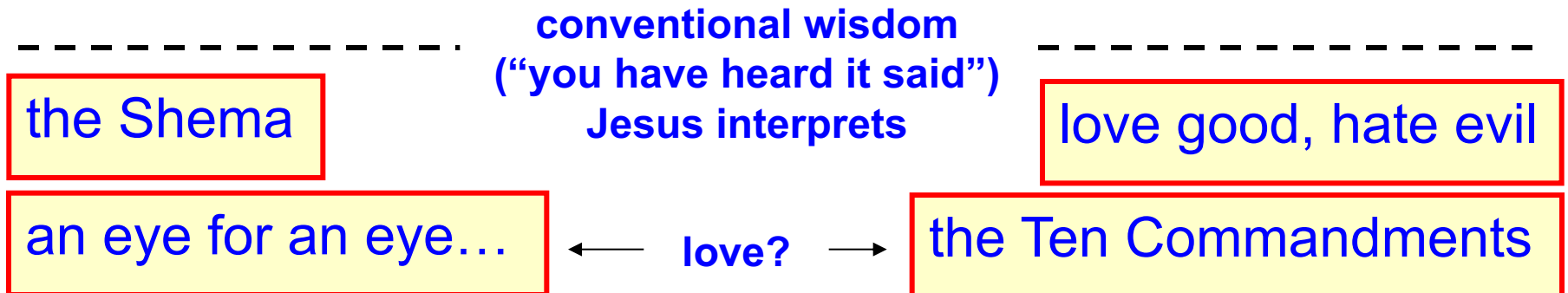

# Are we merely looking for Loopholes?

The Pattern indicates a Structure to build our Soul on.



Do we study the tie points or look at the holes?

# More on Loopholes...

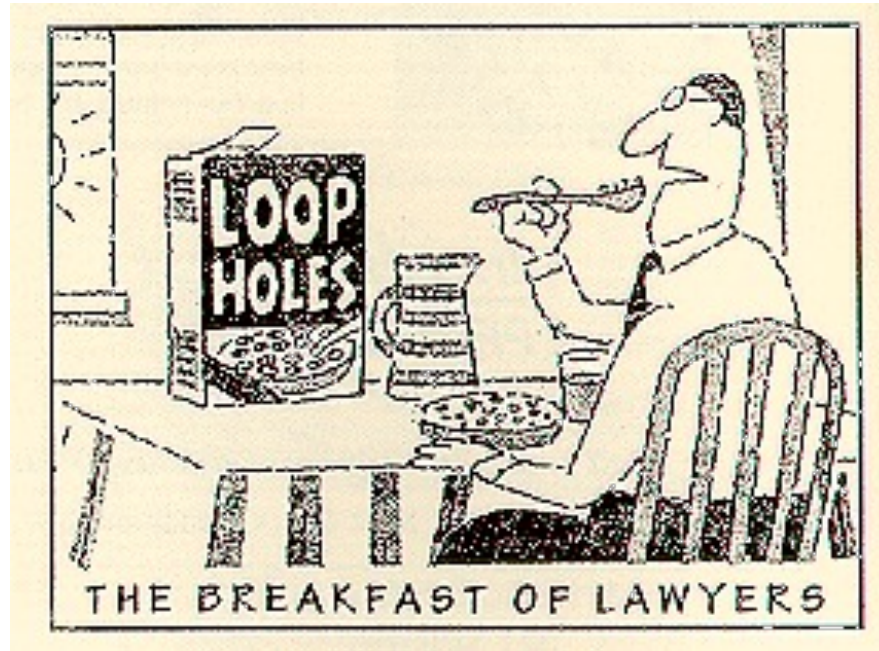

1. Explain Newton's First Law of Motion in your own words.

A cartoon character with spiky hair is sitting at a desk, looking at a book or paper.

!

The cartoon character is sitting at a desk, looking thoughtful with a hand on his chin.

YAKKA FOOB MOG. GRUG  
PUBB4HUP ZINK WATFOOM  
GAZORK. CHUMBLE SPUZZ.

The cartoon character is sitting at a desk, looking confused or frustrated.

I LOVE LOOPHOLES.

The cartoon character is sitting at a desk, smiling broadly with his hands raised in a gesture of triumph or joy.

# The Pattern of God's Plan (7)

The ten commandments talks about not bearing false witness, but doesn't directly address taking an oath.

The basic principle, though, is to be true to your word.

The law as stated in Numbers 30:2 is:

“When a man makes a vow to the LORD or takes an oath to obligate himself by a pledge, he must not break his word but must do everything he said.”

# You have heard it said... (Oaths)

"Again, **you have heard that it was said** to the people long ago, 'Do not break your oath, but keep the oaths you have made to the Lord.'

**But I tell you, Do not swear at all:**

either by heaven, for it is God's throne;

or by the earth, for it is his footstool;

or by Jerusalem, for it is the city of the Great King.

**Integrity**

And do not swear by your head, for you cannot make even one hair white or black.

Simply let your 'Yes' be 'Yes,' and your 'No,' 'No'; anything beyond this comes from the evil one.

**Matthew 5:33-37**

“When a man makes a vow to the LORD or takes an oath to obligate himself by a pledge, he must not break his word but must do everything he said.”

**Numbers 30:2**

# You have heard it said... (Justice)

**"You have heard that it was said, 'Eye for eye, and tooth for tooth.'**

**But I tell you, Do not resist an evil person. If someone strikes you on the right cheek, turn to him the other also.**

**And if someone wants to sue you and take your tunic, let him have your cloak as well.**

**If someone forces you to go one mile, go with him two miles.**

**Give to the one who asks you, and do not turn away from the one who wants to borrow from you.**

**Matthew 5:38-42**

**Live in harmony with one another.**

**Do not be proud, but be willing to associate with people of low position. Do not be conceited. Do not repay anyone evil for evil.**

**Be careful to do what is right in the eyes of everybody.**

**If it is possible, as far as it depends on you, live at peace with everyone.**

**Psalms 34:14 / 1 Peter 3:11  
Seek Peace and Pursue it**

**Romans 12:17-18**

# You have heard it said... (Love and Hate)

**"You have heard that it was said, 'Love your neighbor and hate your enemy.'**

**Connected to the previous category of justice**

**But I tell you: Love your enemies and pray for those who persecute you, that you may be sons of your Father in heaven.**

**He causes his sun to rise on the evil and the good, and sends rain on the righteous and the unrighteous.**

**If you love those who love you, what reward will you get?**

**Are not even the tax collectors doing that?**

**And if you greet only your brothers, what are you doing more than others?**

**Do not even pagans do that?**

**The Jews' "pattern" is no better than the people they despise**

**Be perfect, therefore, as your heavenly Father is perfect."**

**Challenge: Be Like God!**

**Matthew 5:43-48**

# Building the Pattern of Truth

Jesus emphasizes the idea of loving our neighbor here, but he really nails it in the event that we all know so well.

With all of the discussion of the commandments, it was quite natural that someone would ask Jesus which of them was the greatest.

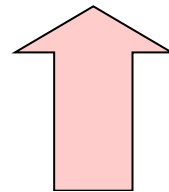

**conventional wisdom**  
("you have heard it said")  
Jesus interprets

the Shema

love good, hate evil

an eye for an eye...

the Ten Commandments

← love? →



**A mind stretched by a new idea  
can never go back to its original dimensions.**

**Oliver Wendell Holmes**

# Building the Pattern of Truth

## Re-interpretations:

Do not murder (Do not hate, but love)

Do not commit adultery (Do not lust; keep your commitments)

Do not break your oath (Do not swear; be dependable and truthful)

Eye for eye and tooth for tooth (Do not resist; seek peace)

Love your neighbor and hate your enemy (Love your enemies and pray for them; be as much like God as possible)

**This was a shock to them**

“you have heard it said”  
Jesus interprets

the Shema

love good, hate evil

an eye for an eye...

← love? →

the Ten Commandments

# Building the Pattern of Truth

Jesus emphasizes the idea of loving our neighbor here, but he really nails it in the event that we all know so well.

With all of the discussion of the commandments, it was quite natural that someone would ask Jesus which of them was the greatest.

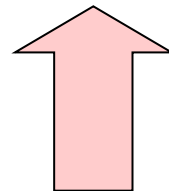

conventional wisdom  
("you have heard it said")  
Jesus interprets

the Shema

love good, hate evil

an eye for an eye...

← love? →

the Ten Commandments

# The Greatest Commandment (1)

One of them, an expert in the law, tested him with this question:

"Teacher, which is the greatest commandment in the Law?"

Jesus replied:

**"Love the Lord your God with all your heart and with all your soul and with all your mind."**

**This is the first and greatest commandment.**

He adds another:

**And the second is like it: 'Love your neighbor as yourself.'**

**All the Law and the Prophets hang on these two commandments."**

Foundation

Matthew 23:35-40

Love God means to love his creation (man)

# The Greatest Commandment (2)

One of the teachers of the law came and heard them debating. Noticing that Jesus had given them a good answer, he asked him, "Of all the commandments, which is the most important?"

"The **most important** one," answered Jesus, "is this:

'Hear, O Israel, the Lord our God, the Lord is one.

**Shema**

**Love the Lord your God with all your heart and with all your soul and with all your mind and with all your strength.'**

The **second** is this: **'Love your neighbor as yourself.'**

There is no commandment greater than these."

Mark 12:28-31

**It is so difficult to love others as ourselves.**

# The Greatest Commandment (3)

"Well said, teacher," the man replied.

"You are right in saying that God is one and there is no other but him.

To love him with all your heart, with all your understanding  
and with all your strength,  
and to love your neighbor as yourself [1\*]  
is **more important** than all burnt offerings and sacrifices."

When Jesus saw that he had answered wisely, he said to him,  
"You are not far from the kingdom of God."

And from then on no one dared ask him any more questions.

Mark 12:28-34

Give yourself as you would in your earthly relationships

# Agape Love can be difficult

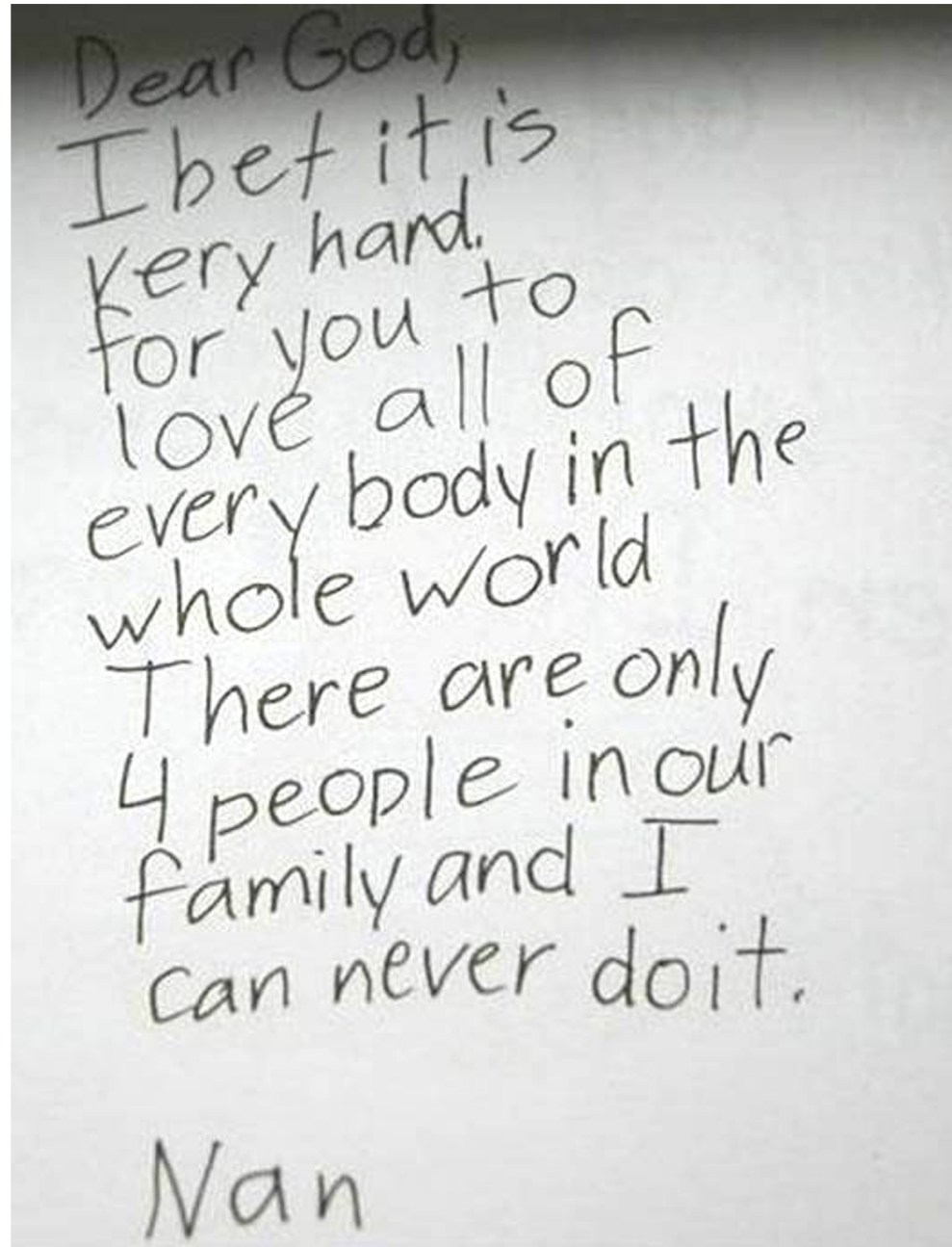
A photograph of a handwritten note on lined paper. The text is written in black ink and is slanted to the right. The note expresses a struggle with the concept of agape love, comparing the difficulty of loving the entire world to the ease of loving one's family.

Dear God,  
I bet it is  
very hard  
for you to  
love all of  
every body in the  
whole world  
There are only  
4 people in our  
family and I  
can never do it.

Nan

# Searching for the Core or for the Shortcut?

**There is a significant difference between a search for the core of meaning and a shortcut to minimize our duty.**

**As Jesus said,  
we must pay full attention to God's entire will.**

"Do not think that I have come to abolish the Law or the Prophets;  
I have not come to abolish them but to fulfill them.  
I tell you the truth, until heaven and earth disappear, not the smallest letter, not the least stroke of a pen, will by any means disappear from the Law until everything is accomplished.

Matthew 5:17-19



# Building the Pattern of Truth

## the Greatest Commands:

1. Love God with all of your heart and soul
2. Love your neighbor as yourself

the Shema

conventional wisdom  
("you have heard it said")  
Jesus interprets

love good, hate evil

an eye for an eye...

← love? →

the Ten Commandments

**Art, like morality,  
consists in drawing the line somewhere.**

**Gilbert K. Chesterton**

# The Pattern of God's Plan (8)

Notice that the one who asked the question in Mark's version **restates** the greatest commandments and stresses their importance (also in a similar passage).

Straightening people out on the real significance of the commandments is what Christ is really after here.

These are not commandments for their own sake, but a means of guiding us into what is really important, that is, to **love**.

Comparison to the standard way of approaching the commandments is a particular passion of the apostle John, who keeps referring to a "new command", which was not actually new.

# **A new command – or pattern (1)**

**A new command I give you: Love one another.  
As I have loved you, so you must love one another.  
By this all men will know that you are my disciples,  
if you love one another.**

**John 13:34-35**

**Dear friends, I am not writing you a new command but an old one,  
which you have had since the beginning.  
This old command is the message you have heard.  
Yet I am writing you a new command...**

**1 John 2:7-8**

**This is the message you heard from the beginning:  
We should love one another.**

**1 John 3:11**

**We all need a fresh, new perspective.**

# Similar language...

This language is so similar to the  
“You have heard it said...”

Except that John is saying  
that what God wants now  
is what He wanted from the beginning,  
and that which we missed along the way.

**Like the Greatest Commands -- Not new, but re-newed.**

# A new command – or pattern (2)

John adds to this in his letters.

**And now, dear lady, I am not writing you a new command  
but one we have had from the beginning.**

**I ask that we love one another.**

**2 John 1:5**

**And now, dear lady, I am not writing you a new command  
but one we have had from the beginning.**

**I ask that we love one another.**

**And this is love: that we walk in obedience to his commands.**

**As you have heard from the beginning,  
his command is that you walk in love.**

**2 John 1:5-6**

**Love is the foundation for the law.**

# Obedience to the Ten Commandments (1)

Look at how Jesus talks about the Commandments.

Now a man came up to Jesus and asked, "Teacher, what **good thing** must I do to get eternal life?"

"Why do you ask me about what is good?" Jesus replied.

"There is only One who is good. If you want to enter life, obey the commandments."

"Which ones?" the man inquired.

**Why not all of them?**

Jesus replied, "'Do not murder [6], do not commit adultery [7], do not steal [8], do not give false testimony [9], honor your father and mother [4], and **'love your neighbor as yourself [2\*].'**"

Matthew 19:16-19

# Obedience to the Ten Commandments (2)

**"All these I have kept,"** the young man said. **"What do I still lack?"**

Jesus answered, **"If you want to be perfect, go, sell your possessions and give to the poor, and you will have treasure in heaven. Then come, follow me."**

**When the young man heard this, he went away sad, because he had great wealth.**

**Then Jesus said to his disciples, "I tell you the truth, it is hard for a rich man to enter the kingdom of heaven. Again I tell you, it is easier for a camel to go through the eye of a needle than for a rich man to enter the kingdom of God."**

**When the disciples heard this, they were greatly astonished and asked, "Who then can be saved?"**

**Jesus looked at them and said, "With man this is impossible, but with God all things are possible."**

**Matthew 19:20-26**



# The Pattern of God's Plan (9)

Jesus lists five (5) of the ten commandments,  
and then includes in the list  
the command to love our neighbor as ourselves.

He did not include the greatest commandment,  
but you notice that He does emphasize  
the ultimate Goodness of God.

In Luke's presentation of a similar scene,  
he has the questioner answer.

This man has probably heard Jesus' comments  
on the greatest commandments and answers properly.

But it is almost as though he feels bad about it,  
and questions further  
about the definition of the word neighbor.

# Neighbor: OT perspective

Look at what the Bible says about our neighbor from the Old Testament perspective.

**Do not hate your brother in your heart.**

**Rebuke your neighbor frankly so you will not share in his guilt.**

**Do not seek revenge or bear a grudge against one of your people,  
but love your neighbor as yourself [2\*].**

**I am the LORD.**

**Leviticus 19:17-18**

This is part of the preparation for laying foundation for what Jesus calls the second greatest commandment.

Most people don't realize that Jesus was quoting from the Old Testament when he gave his verdict..

# Neighbor: NT Perspective

On one occasion an expert in the law stood up to test Jesus.

"Teacher," he asked, "what must I do to inherit eternal life?"

"What is written in the Law?" he replied. "How do you read it?"

He answered: "'Love the Lord your God with all your heart and with all your soul and with all your strength and with all your mind [1\*]' ; and, 'Love your neighbor as yourself [2\*].'"

"You have answered correctly," Jesus replied.

"Do this and you will live."

But he wanted to justify himself, so he asked Jesus,

"And who is my neighbor?"

Luke 10:25-29

We all know the story of the Good Samaritan:  
brother/neighbor --> all people

# The Pattern of God's Plan (10)

The critical summary was asked by Jesus in verse 36:

"Which of these three do you think was a neighbor to the man who fell into the hands of robbers?"

There was obviously only one answer.

“The one who had mercy on him.”

Jesus spoke of the two greatest commandments as being the foundation for all Goodness and Law.

Paul speaks of it in a similar way.

There is neither Jew nor Greek, slave nor free, male nor female, for you are all one in Christ Jesus.

Galatians 3:28-29

**The universe quietly reveals its unity.**

**God is polite, knocking only gently.**

**We have to listen carefully  
if we are to hear the report.**

**Gerald Schroeder**

# The Pattern of God's Plan (11?)

God has given us the pattern that he wants us to follow.

We are to love each other, not as a new command, but as a renewal of the original picture of God's Truth and Will.

Love is the foundation for all interpretations of that Truth.

None of us understand the true magnitude of God's Love.

The key is to know who to love -- who is our neighbor and brother? Answer: Everyone!

# Building the Pattern of Truth



the Greatest Commands:

1. Love God with all of your heart and soul
2. Love your neighbor as yourself

the Shema

conventional wisdom  
("you have heard it said")  
Jesus interprets

love good, hate evil

an eye for an eye...

← love? →

the Ten Commandments

# Summary of the Commandments

The commandments, "Do not commit adultery [7],"  
"Do not murder [6],"  
"Do not steal [8],"  
"Do not covet [10],"

**What about the other  
commandments?**

and whatever other commandment there may be,  
are summed up in this one rule:

"Love your neighbor as yourself [2\*]."

Love does no harm to its neighbor.

Therefore love is the **fulfillment** of the law.

**Romans 13:9-10**

The entire law is **summed up** in a single command:

"Love your neighbor as yourself [2\*]."

**Galatians 5:14**

If you really keep the royal law found in Scripture,

"Love your neighbor as yourself [2\*]," you are doing right.

**James 2:8**



# Building the Pattern of Truth



## the Greatest Commands:

1. Love God with all of your heart and soul
2. Love your neighbor as yourself

**Foundation/  
Summary:  
Rom 13:9-10  
(love)**

the Shema

conventional wisdom  
("you have heard it said")  
Jesus interprets

love good, hate evil

an eye for an eye...

← love? →

the Ten Commandments

# The Pattern of God's Plan (11)

Many people think  
that you just have to be a good person  
to make it into heaven.

They look to another sort of summary to express this,  
what is generally called the “golden rule”.

# The Golden Rule

**So in everything,**

**do to others what you would have them do to you,  
for this sums up the Law and the Prophets.**

**Matthew 7:12**

**Do to others as you would have them do to you.**

**Luke 6:31**

**Paul gives additional insight to this:**

**Each of us should please his neighbor for his good, to build him up.  
Romans 15:2**

# The Golden Rule -- Variations

**BUDDHISM:** Hurt not others in ways  
that you yourself would find hurtful.

**HINDUISM:** Do nothing to others  
that which if done to you would cause pain.

**ISLAM:** No one of you is a believer  
until he desires for his brother  
that which he desires for himself.

**BAHA'I FAITH:** Choose for your neighbor  
that which you choose for yourself.

**JUDAISM:** Love your neighbor as yourself.

**CHRISTIANITY:** Do unto others  
as you would have them do unto you.

# The Golden Rule -- Norman Rockwell Style

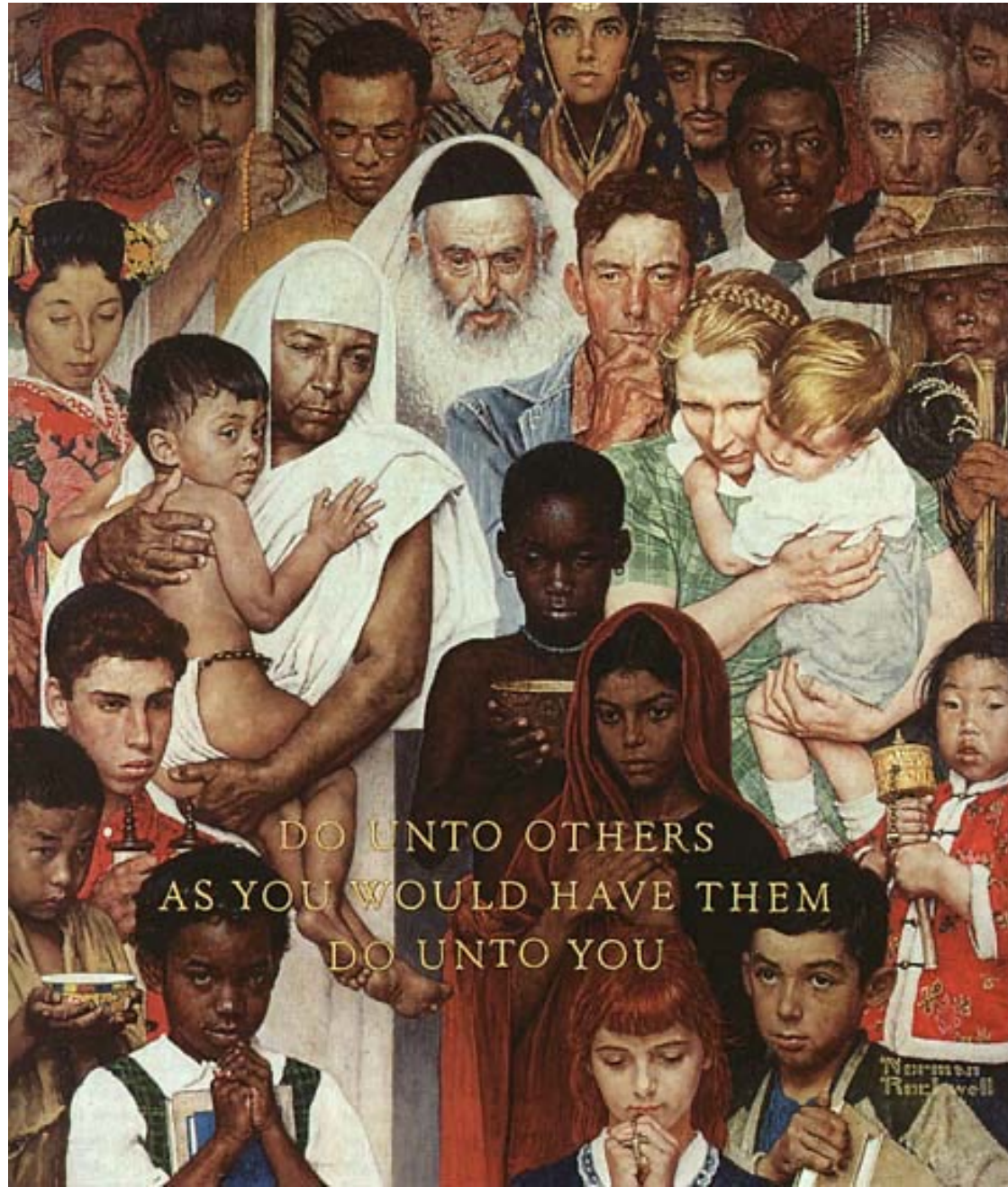

# Building the Pattern of Truth

the Golden Rule (Mat 7:12):  
treat others as you want to be treated

we weaken this to 

the Greatest Commands:  
1. Love God with all of your heart and soul  
2. Love your neighbor as yourself

Foundation/  
Summary:  
Rom 13:9-10  
(love)

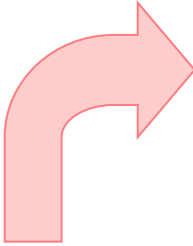

the Shema

conventional wisdom  
("you have heard it said")  
Jesus interprets

love good, hate evil

an eye for an eye...

← love? →

the Ten Commandments

**To love another person  
is to see the face of God.**

**From the musical Les Miserables**

# Building the Pattern of Truth

## REVIEW DIAGRAM

the Golden Rule (Mat 7:12):  
treat others as you want to be treated

we weaken (shortcut) this to 

the Greatest Commands:  
1. Love God with all of your heart and soul  
2. Love your neighbor as yourself

Foundation/  
Summary:  
Rom 13:9-10  
(love)

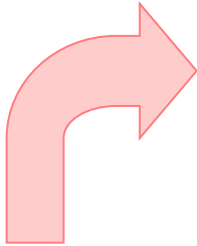

the Shema

conventional wisdom  
("you have heard it said")  
Jesus interprets

love good, hate evil

an eye for an eye...

← love? →

the Ten Commandments



# The Pattern of God's Plan (12)

This is very practical (group management survival technique), but not very spiritual.

**Is this Good enough for God?**

Does this really address what He really wants?

It is pretty selfish:

treating others well so that we would be treated well.

It seems to be reactionary -- relating to local interactions (not global in nature).

The second greatest commandment is similar, it connects our love for others to our love for our self.

**The Golden Rule by itself does not have  
the real Power of Love.**

# Building the Pattern of Truth



# A Step Beyond The Golden Rule

**Paul takes things a step higher.**

**Nobody should seek his own good,  
but the good of others.**

**1 Corinthians 10:24**

**Here we are to minimize self,  
and love others more than we do ourselves.**

# A Step Beyond The Golden Rule

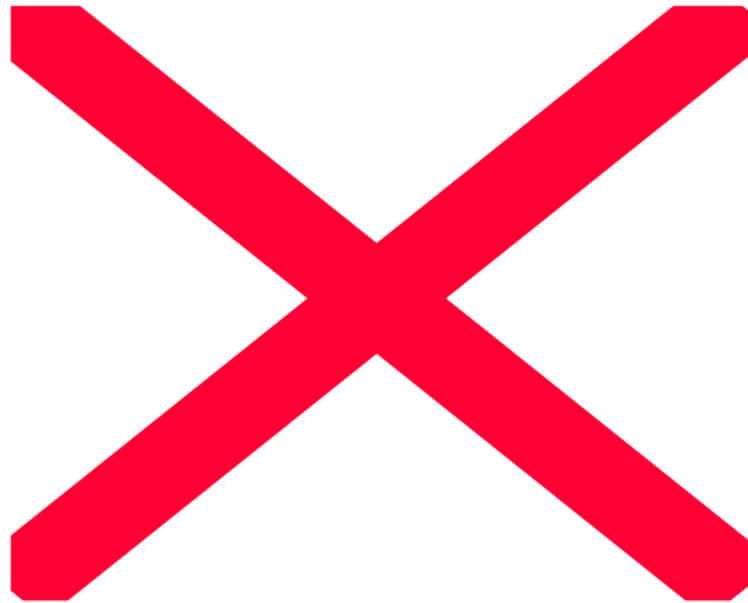

# Building the Pattern of Truth

Practical,  
but not  
spiritual

the Golden Rule (Mat 7:12):  
treat others as you want to be treated  
seek the good of others (1 Cor 10:24)

Is this  
enough to  
please God?

we weaken (shortcut) this to

the Greatest Commands:

1. Love God with all of your heart and soul
2. Love your neighbor as yourself

Foundation/  
Summary:  
Rom 13:9-10  
(love)

conventional wisdom  
("you have heard it said")  
Jesus interprets

the Shema

love good, hate evil

an eye for an eye...

← love? →

the Ten Commandments

# The Pattern of God's Plan (13)

This is an improvement  
in that it causes us to think about others  
rather than ourselves.

But is this enough to please God?

What do we tell people when they say  
that all you really need to do is to be good  
and God will accept you?

There is something else to consider that is so profound  
that it takes our breath away,  
and that is the cross.

And there is no better way to describe it than John 3:16.

# The Cross creates an **intimate relationship** that soars above the Golden Rule

**For God so loved the world**

**that he gave his one and only Son,**

**that whoever believes in him shall not perish**

**but have eternal life.**

**John 3:16**

**It is only by acting through this type of love  
that living by the Golden Rule  
actually means anything.**

# The Golden Rule must be Implemented



# Building the Pattern of Truth



# The Pattern of God's Plan (14)

This represents a level so much higher than the Golden Rule.

It establishes a **relationship** with God  
through the love that He has shown us  
in this tremendous act of self-sacrifice.

It reflects what God established in the Old Testament  
and Jesus emphasized in the New,  
that the greatest wish of God  
(expressed through His commands)  
is to love Him with all of our heart.

This means, similarly,  
that we must have a relationship with Him.

# The Pattern of God's Plan (15)

And the other wish of God  
is that we should love all mankind.

It is only by acting through this love  
that living by the Golden Rule  
actually means anything.

God elevates the idea of a relationship  
into the level of **intimacy**.

# Building the Pattern of Truth



# True Love

**Dear friends, let us love one another, for love comes from God.**

**Everyone who loves has been born of God and knows God.**

**Whoever does not love does not know God, because God is love.**

**This is how God showed his love among us:**

**He sent his one and only Son into the world that we might live through him.**

**This is love: not that we loved God, but that he loved us and sent his Son as an atoning sacrifice for our sins.**

**Dear friends, since God so loved us, we also ought to love one another.**

**No one has ever seen God; but if we love one another, God lives in us and his love is made complete in us.**

**1 John 4:7-12**

# Building the Pattern of Truth

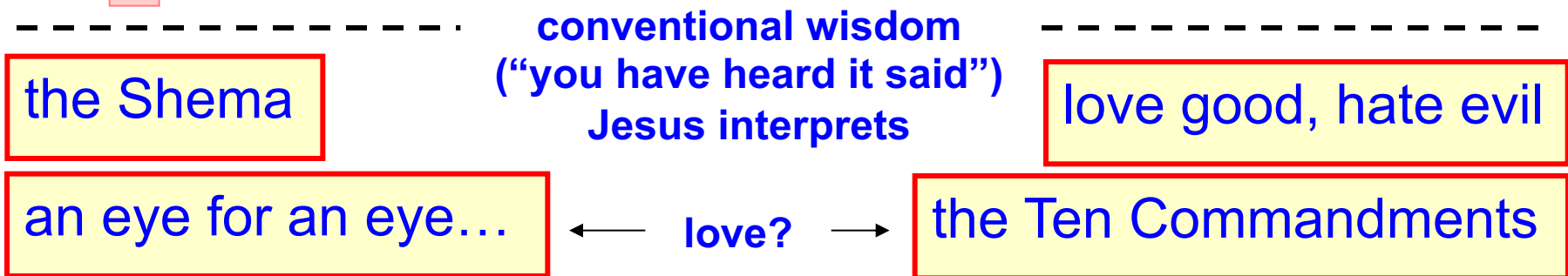
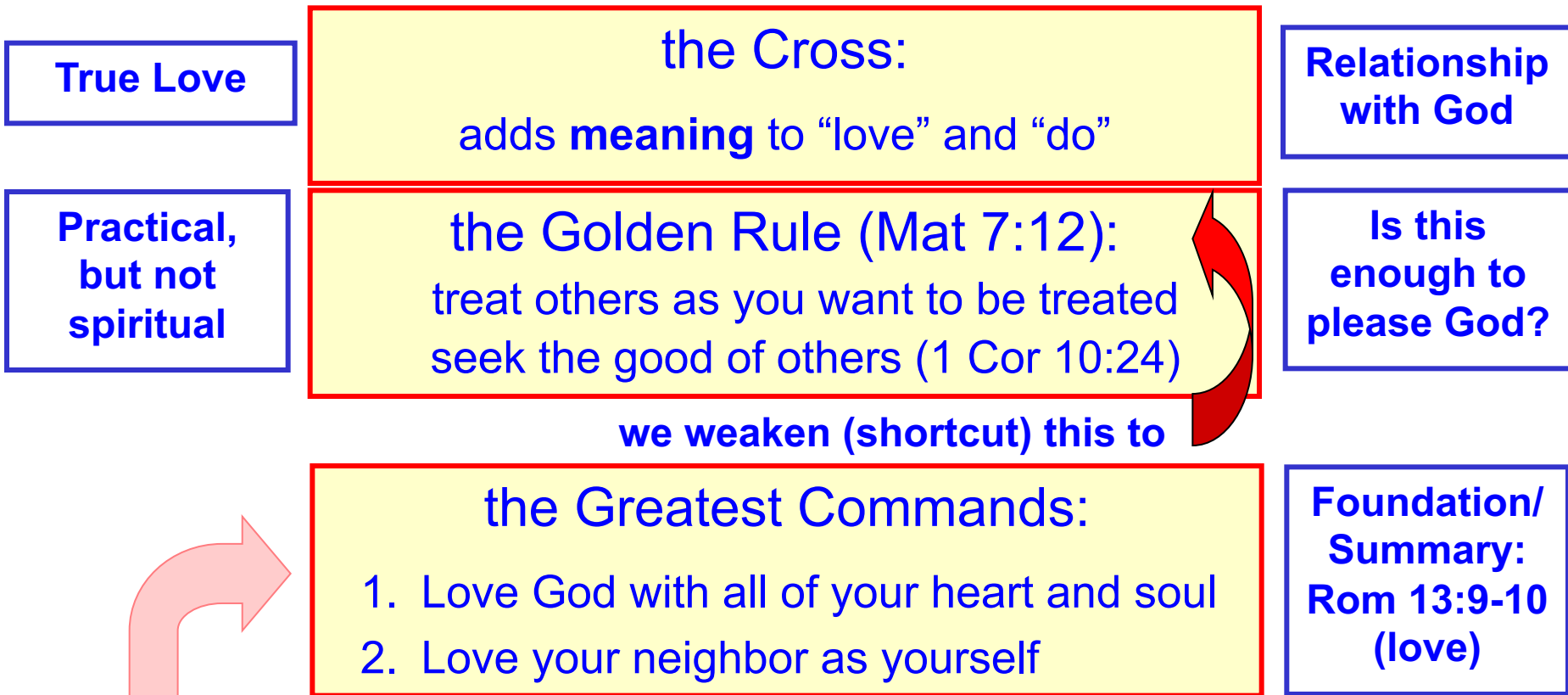

**I really only love God as much  
as I love the person I love the least.**

**Dorothy Day**

# The Pattern of God's Plan (1)

God has given us the pattern that he wants us to follow.

It is important to determine the basis of our spiritual life.

The core begins with our Jewish heritage.

The first level is the ten commandments, thought of by the Israelites as the ultimate set of rules for their behavior.

Local justice allowed an eye for an eye / a tooth for a tooth.

The **Shema** speaks of loving God with all of our being.

And **we should love whatever God loves** (His creation).

God wants people to love each other, and to see the great contrast between Good and Evil.

Jesus contrasts God's pattern to that of the Pharisees in the Sermon on the Mount.



# The Pattern of God's Plan (2)

God has given us the pattern that he wants us to follow.

We are to love each other, not as a new command, but as a renewal of the original picture of God's Truth and Will.

Love is the foundation for all interpretations of that Truth.  
Emphasized by Christ, Paul, James, etc.

None of us understand the true magnitude of God's Love.

The key is to know who to love --  
who is our neighbor and brother?  
Answer: Everyone!

Is the Golden Rule comprehensive enough to please God?  
By itself it does not have the power of Love.

We are to minimize self --  
to love others more than we do ourselves.

# The Golden Rule must be Implemented

# The Cross creates an **intimate relationship** that soars above the Golden Rule

**For God so loved the world**

**that he gave his one and only Son,**

**that whoever believes in him shall not perish**

**but have eternal life.**

**John 3:16**

**It is only by acting through this type of love  
that living by the Golden Rule  
actually means anything.**

# Building the Pattern of Truth

## REVIEW DIAGRAM

True Love

the Cross:  
adds meaning to "love" and "do"

Relationship with God

Practical, but not spiritual

the Golden Rule (Mat 7:12):  
treat others as you want to be treated  
seek the good of others (1 Cor 10:24)

Is this enough to please God?

we weaken (shortcut) this to

the Greatest Commands:  
1. Love God with all of your heart and soul  
2. Love your neighbor as yourself

Foundation/ Summary:  
Rom 13:9-10  
(love)

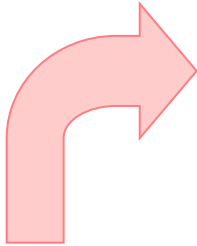

the Shema

conventional wisdom  
("you have heard it said")  
Jesus interprets

love good, hate evil

an eye for an eye...

← love? →

the Ten Commandments

**Belief in Jesus Christ as the Son of God  
is not something that we can just ignore.**

**Indeed it is the **foundation** of the **relationship**  
that we have with God.**

# The Rock and Foundation (1)

Jesus... asked his disciples,

"Who do people say the Son of Man is?"

They replied,

"Some say John the Baptist; others say Elijah;  
and still others, Jeremiah or one of the prophets."

"But what about you?" he asked. "Who do you say I am?"

Simon Peter answered,

**"You are the Christ, the Son of the living God."**

Jesus replied, "Blessed are you, Simon son of Jonah,  
for this was not revealed to you by man,  
but by my Father in heaven.

**Matthew 16:13-16**

# The Rock and Foundation (2)

And I tell you that you are Peter,

and **on this rock**

I will build my church,

and the gates of Hades

will not overcome it.

I will give you the keys of the kingdom of heaven;

whatever you bind on earth

will be bound in heaven,

and whatever you loose on earth

will be loosed in heaven.”

**Matthew 16:17-19**

# Building the Pattern of Truth

this returns the power

The added critical level: personal

Foundation Rock

True Love the Cross:  
adds meaning to "love" and "do"

Relationship with God

Practical, but not spiritual

the Golden Rule (Mat 7:12):  
treat others as you want to be treated  
seek the good of others (1 Cor 10:24)

Is this enough to please God?

we weaken (shortcut) this to

the Greatest Commands:  
1. Love God with all of your heart and soul  
2. Love your neighbor as yourself

Foundation/ Summary:  
Rom 13:9-10 (love)

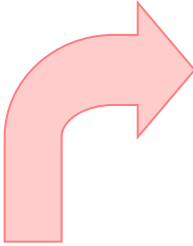

the Shema

conventional wisdom ("you have heard it said")  
Jesus interprets

love good, hate evil

an eye for an eye...

← love? →

the Ten Commandments



**This is the added critical level  
that must be added to the Golden Rule.**

**And because it differs from the common (hopeful)  
understanding of so many people,  
it means that we must **talk** about this to others.**

**We must enable them to see the complete picture,  
helping them to believe  
that they also must embrace this relationship.**

# True Love Restated

**There is real power in this True Love!**

**For God so wanted**

**an intimate relationship with His people,  
that He gave His one and only Son,  
that whoever was irresistibly drawn to Him  
would become His child as well.**

**This relationship is eternal!**

# Building the Pattern of Truth

this returns the power



The added critical level

We must talk about this to others

Foundation Rock

True Love

the Cross:

adds meaning to "love" and "do"

Relationship with God

Practical, but not spiritual

the Golden Rule (Mat 7:12):  
treat others as you want to be treated  
seek the good of others (1 Cor 10:24)

Is this enough to please God?



we weaken (shortcut) this to

the Greatest Commands:  
1. Love God with all of your heart and soul  
2. Love your neighbor as yourself

Foundation/ Summary:  
Rom 13:9-10 (love)

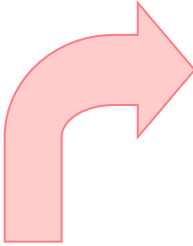

the Shema

conventional wisdom ("you have heard it said")  
Jesus interprets

love good, hate evil

an eye for an eye...

← love? →

the Ten Commandments

# Structure without Heart



**We may have a strong structure,  
but does it contain anything?**

**Thou shalt not be ridiculous!**

**John Ortberg**

**(proposed as the eleventh commandment)**

# The Inverse Golden Rule?

**If someone treats us badly,  
Can we treat them in the same manner,  
Assuming that they were using the Golden Rule,  
And wanted to be treated that way?**

The ten commandments are considered the ultimate set of rules for their behavior.

Local justice allowed an eye for an eye / a tooth for a tooth.

The **Shema** speaks of loving God with all of our being.

And **we should love whatever God loves** (His creation).

God wants us to love each other; to love Good and hate Evil.

Who is our neighbor and brother?          Answer: Everyone!

We are really to love others **more** than we do ourselves.

The Golden Rule by itself it does not have the power of Love.

The Cross creates an **intimate relationship**  
that soars above the Golden Rule!

# The Anticipatory Golden Rule?

**Do unto others before they do unto you.**



The ten commandments are considered the ultimate set of rules for their behavior.

Local justice allowed an eye for an eye / a tooth for a tooth.

The **Shema** speaks of loving God with all of our being.

And **we should love whatever God loves** (His creation).

God wants us to love each other; to love Good and hate Evil.

Who is our neighbor and brother?          Answer: Everyone!

We are really to love others **more** than we do ourselves.

The Golden Rule by itself it does not have the power of Love.

The Cross creates an **intimate relationship**  
that soars above the Golden Rule!

# **Samson's Own Golden Rule / eye for eye (1)**

**After Samson lost his first wife to his "friend",  
and burned the fields of the Philistines. (Judges 15)**

**When the Philistines asked, "Who did this?"  
they were told,**

**"Samson, the Timnite's son-in-law,  
because his wife was given to his friend."**

**So the Philistines went up  
and burned her and her father to death.**

**Samson said to them, "Since you've acted like this,  
I won't stop until I get my revenge on you."**

**He attacked them viciously and slaughtered many of them.**

## Samson's Own Golden Rule / eye for eye (2)

The Philistines went up and camped in Judah, spreading out near Lehi.

The men of Judah asked, "Why have you come to fight us?"

"We have come to take Samson prisoner," they answered, **"to do to him as he did to us."**

Then three thousand men from Judah went down to the cave in the rock of Etam and said to Samson,

"Don't you realize that the Philistines are rulers over us? What have you done to us?"

He answered, **"I merely did to them what they did to me."**

**Each side was responding to what was done to them.**

The ten commandments are considered the ultimate set of rules for their behavior.

Local justice allowed an eye for an eye / a tooth for a tooth.

The **Shema** speaks of loving God with all of our being.

And **we should love whatever God loves** (His creation).

God wants us to love each other; to love Good and hate Evil.

Who is our neighbor and brother?          Answer: Everyone!

We are really to love others **more** than we do ourselves.

The Golden Rule by itself it does not have the power of Love.

The Cross creates an **intimate relationship**  
that soars above the Golden Rule!

## Platinum Rule:

"Do unto others **even better** than  
you would have them do unto you."

**See 1 Corinthians 6:24**

The ten commandments are considered the ultimate set of rules for their behavior.

Local justice allowed an eye for an eye / a tooth for a tooth.

The **Shema** speaks of loving God with all of our being.

And **we should love whatever God loves** (His creation).

God wants us to love each other; to love Good and hate Evil.

Who is our neighbor and brother?          Answer: Everyone!

We are really to love others **more** than we do ourselves.

The Golden Rule by itself it does not have the power of Love.

The Cross creates an **intimate relationship**  
that soars above the Golden Rule!

# The Golden Rule Must Be Implemented

17



**We ignore it like we do the metric system.**

The ten commandments are considered the ultimate set of rules for their behavior.

Local justice allowed an eye for an eye / a tooth for a tooth.

The **Shema** speaks of loving God with all of our being.

And **we should love whatever God loves** (His creation).

God wants us to love each other; to love Good and hate Evil.

Who is our neighbor and brother?            Answer: Everyone!

We are really to love others **more** than we do ourselves.

The Golden Rule by itself it does not have the power of Love.

The Cross creates an **intimate relationship**  
that soars above the Golden Rule!



# Another Golden Rule

**He who has the Gold,  
Makes the Rules!**

The ten commandments are considered the ultimate set of rules for their behavior.

Local justice allowed an eye for an eye / a tooth for a tooth.

The **Shema** speaks of loving God with all of our being.

And **we should love whatever God loves** (His creation).

God wants us to love each other; to love Good and hate Evil.

Who is our neighbor and brother?          Answer: Everyone!

We are really to love others **more** than we do ourselves.

The Golden Rule by itself it does not have the power of Love.

The Cross creates an **intimate relationship**  
that soars above the Golden Rule!

# More Beyond the Golden Rule

**Almost all religions adopt some form  
of the Golden Rule as a premise,  
but Jesus was alone in commanding that we  
forgive enemies,  
turn the other cheek,  
or walk the second mile.**

**Jimmy Carter**

- **Introduction**
- **The Perception Process**
- **Pattern Structure**
- **The Pattern of God's Plan**
- **Critical Patterns**
  - Law
  - Church
  - Family
  - God's Goodness
  - Personal
- **Developing the Pattern God Wants in Us**
- **Summary**

**$2 + 2 \equiv 4$  (always true)**

$$\mathbf{V_{tot} = V_1 + V_2}$$

**(only at low speeds)**

**There's a modification for relativity.**



Is this law a guideline or a demand?

# Green light means Go!



# Green light means Go!

**Think about rules -- What mitigates this “law”?**

**Green at the traffic light in front of you --**

**Does this always mean GO?**

**What if there is a car in front of you?**

**If there is a car in front of you... can you just sit there?**

**Ultimately the police will make you move –**

**There is a balance between**

**can't go,**

**can go, and**

**must go.**



# The Full Truth is wrapped around the Structure <sup>12</sup>

We think of discrete laws, one here, one there  
like a single line;  
but Good involves fitting the pattern  
over a wide range of parameters;  
like forecasting the weather,  
or adding surface to a structure.

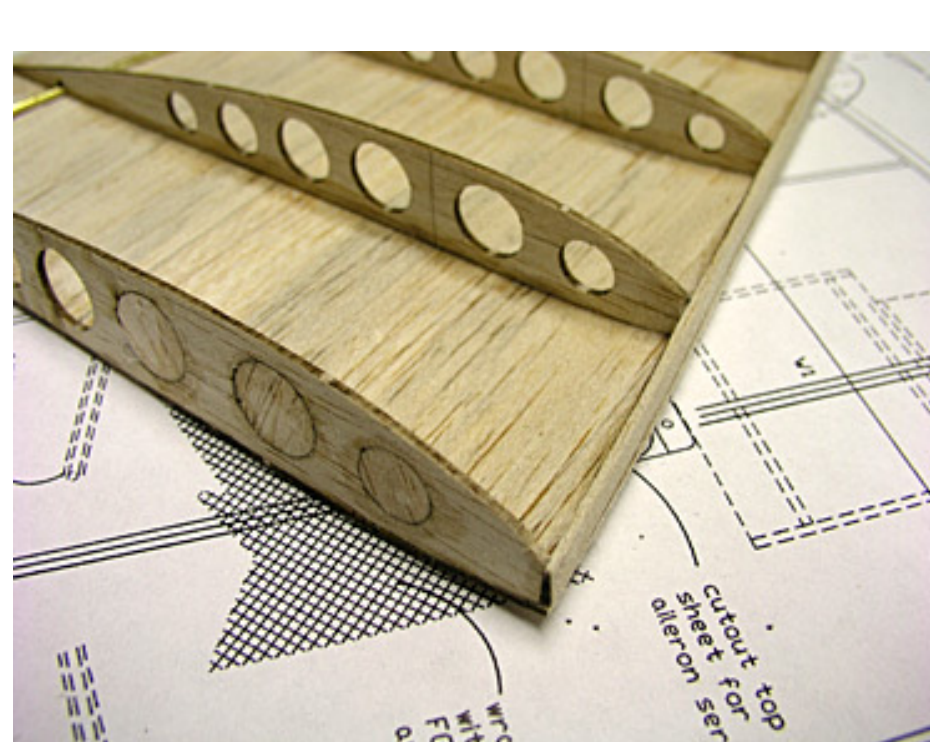

**Can a comprehensive set of laws be written  
that is not subject to interpretation?**

**This was tried with Mathematics, and it didn't work.**

**Law must be interpreted for Good;  
interpretation must not be used as  
an excuse to ignore parts of the law we don't like!**

**We are always looking for loopholes!**

**Return to our starting point: the Tabernacle**

**The knowledge of God  
is very far  
from the love of Him.**

**Blaise Pascal**

# The Sacred Fire (Original Miracle)

**Moses and Aaron then went into the Tent of Meeting.  
When they came out, they blessed the people;  
and the glory of the LORD appeared to all the people.**

**Fire came out from the presence of the LORD  
and consumed the burnt offering  
and the fat portions on the altar.**

**And when all the people saw it,  
they shouted for joy and fell facedown.**

**Leviticus 9:23-24**

**God provided a sacred spark!**

The fire on the altar must be kept burning;  
**it must not go out.**

Every morning the priest is to add firewood  
and arrange the burnt offering on the fire  
and burn the fat of the fellowship offerings on it.

The fire must be kept burning on the altar continuously;  
**it must not go out.**

**Leviticus 6:12-13**

**What if the fire goes out?**

# The Sacred Fire (after the captivity)

Jeshua... and his fellow priests and Zerubbabel... and his associates began to **build the altar** of the God of Israel to sacrifice burnt offerings on it, in accordance with what is written in the Law of Moses the man of God.

Despite their fear of the peoples around them, they **built the altar on its foundation and sacrificed burnt offerings on it** to the LORD, both the morning and evening sacrifices...

On the first day of the seventh month they began to offer burnt offerings to the LORD, though the foundation of the LORD's temple had not yet been laid.

Ezra 3:3-6

**They had no miraculous fire starter!**

**They relit it, (admitted their sin) and went on.**

# The Sacred Fire (a new kingdom)

When the day of Pentecost came,  
they were all together in one place.

Suddenly a sound like the blowing of a violent wind  
came from heaven and filled the whole house  
where they were sitting.

They saw what seemed to be **tongues of fire**  
that separated and came to rest on each of them.

All of them were filled with the Holy Spirit  
and began to speak in other tongues  
as the Spirit enable them.

**Acts 2:1-5**

**God started the fire again for the new kingdom.  
Each of us is a new altar to accomplish His work.**

# The Unauthorized Fire

**Aaron's sons Nadab and Abihu took their censers,  
put fire in them and added incense;  
and they offered unauthorized fire before the LORD,  
contrary to his command.**

**So fire came out from the presence of the LORD  
and consumed them,  
and they died before the LORD.**

**Leviticus 10:1-2**

**They tried to make their own nation --  
they offered unauthorized fire without regarding God;  
the proper fire was still lit  
Were they punished simply because they broke a rule  
or because they disturbed a deeper pattern  
God was trying to establish?**



**Unless we know the difference  
between flowers and weeds,  
we are not fit to take care of a garden.**

**It is not enough to have truth planted in our minds.**

**We must learn and labor to keep the ground clear  
of thorns and briars, follies and perversities,  
which have a wicked propensity  
to choke the word of life.**

**Clyde Francis Lytle**

# The Sabbath: Law or Sign?

... I gave them my Sabbaths as a sign between us,  
so they would know that I the LORD made them holy.

Keep my Sabbaths holy,

that they may be a sign between us.

Then you will know that I am the LORD your God."

Ezekiel 20:12, 16, 20

The Sabbath was intended

to make the nation separate from the world.

Desecration of the Sabbath

indicated a rebuff of the special **relationship**  
held with God.

# The Story of Jephthah

**An example of the false interpretation of a pattern**

**Jephthah offered the first thing that came out of his house if God would bring him victory (Judges 11:30-40).**

**To his horror, it turned out to be his daughter.**

**He was trying to fit the pattern of sacrifice as he understood it from the core of the OT**

**It is the core of the NT, too, but with the personality of God (Christ) infused throughout.**

**People then (as now) try to put the structure [of Truth] in their own terms.**

**Ray Marcrom**

# The Unchangeable Law of the Medes and Persians<sup>14</sup>

**Man is not capable of generating perfect law.**

**Darius was trapped by this policy --**

**It caused him to throw Daniel in the lion's den.**

**Later it caused Xerxes to condemn the Jewish exiles --**

**But another law was added**

**that enabled them to defend themselves.**

**The law could not be changed,**

**but it still could be manipulated!**

**Do we try to create the same thing in our traditions?**

# **The Pattern of Things to Come**

**The Old Testament was a Pattern  
for the Kingdom to Come**

**It was a basis, not an exact template.  
It was a pattern that helped us learn the Truth.**

**Concerning this salvation, the prophets,  
who spoke of the grace that was to come to you,  
searched intently with the greatest care,  
trying to find out the time and circumstances  
to which the Spirit of Christ in them was pointing  
when he predicted the sufferings of Christ  
and the glories that would follow.**

**1 Peter 1:10**

**The prophets were also trying to see the new pattern.**

# The pattern of that which was to come (Christ) <sup>14</sup>

Nevertheless,  
death reigned from the time of Adam  
to the time of Moses,  
even over those who did not sin  
by breaking a command,  
as did Adam,  
who was a **pattern** of the one to come.

Romans 5:14

**Pattern: type, figure, picture, prelude, look or point ahead**

**Christ came to show the perfected pattern**

# The Pattern of Things to Come

**Jesus Christ overlaid His Pattern over the Old Testament  
to show the character of the New Kingdom**

**The Jesus pattern overlaid on the OT:**

**I am the light**

**I am the life**

**I am the bread**

**I am the living water**

**God is my Father**

**This is my body, my blood**

**Hung on a tree as a sacrifice**

**Much of this was unacceptable to  
the current interpretation of the “law”**

# Christ's Interpretation of the Law

**Jesus did not come to free us from the law.  
He came to free us from our sin.**

**"Do not think that I have come  
to abolish the Law or the Prophets;  
I have not come to abolish them but to fulfill them.  
I tell you the truth,  
until heaven and earth disappear,  
not the smallest letter,  
not the least stroke of a pen,  
will by any means disappear from the Law  
until everything is accomplished.**

**Matthew 15:17-18**

**The Bible is not a law book, but a love letter.**

**Ray Marcrom**



# **Christ's Interpretation of the Intent of the Law (1)<sup>14</sup>**

**At that time Jesus went through the grainfields  
on the Sabbath.**

**His disciples were hungry  
and began to pick some heads of grain and eat them.**

**When the Pharisees saw this, they said to him, "Look!  
Your disciples are doing  
what is unlawful on the Sabbath."**

**Matthew 12:1-2**

**The Pharisees were ready to pounce on Christ to  
embarrass Him in front of His audience.**

## **Christ's Interpretation of the Intent of the Law (2)<sup>14</sup>**

**He answered,**

**"Haven't you read what David did  
when he and his companions were hungry?**

**He entered the house of God,  
and he and his companions  
ate the consecrated bread —  
which was not lawful for them to do,  
but only for the priests.**

**Or haven't you read in the Law that on the Sabbath  
the priests in the temple desecrate the day  
and yet are innocent?**

**Matthew 12:3-5**

# **Christ's Interpretation of the Intent of the Law (3)<sup>14</sup>**

**I tell you that one greater than the temple is here.**

**If you had known what these words mean,  
'I desire mercy, not sacrifice,'  
you would not have condemned the innocent.**

**For the Son of Man is Lord of the Sabbath."**

**Matthew 12:6-8**

## **Christ's Interpretation of the Intent of the Law (4)<sup>14</sup>**

**Going on from that place, he went into their synagogue,  
and a man with a shriveled hand was there.**

**Looking for a reason to accuse Jesus,  
they asked him,  
"Is it lawful to heal on the Sabbath?"**

**He said to them,  
"If any of you has a sheep  
and it falls into a pit on the Sabbath,  
will you not take hold of it and lift it out?  
How much more valuable is a man than a sheep!**

**Therefore it is lawful to do good on the Sabbath."**

**Matthew 12:9-13**

**The intent of the Law is to do Good.**

# **Christ's Interpretation of the Intent of the Law (5)<sup>14</sup>**

**Then he said to the man,  
"Stretch out your hand."**

**So he stretched it out  
and it was completely restored,  
just as sound as the other.**

**But the Pharisees went out  
and plotted how they might kill Jesus.**

**Matthew 12:13-14**

**Those that used the law for their own ends,  
abandoned it quickly when it suited their purpose.**

**Was Christ saying that the law was too restrictive?**

**Or was He just trying to invoke the right interpretation?**

**He wants us all to understand the purpose of the Law:  
It must lead to Good!**

**Life is full of obstacle illusions.**

**Grant Frazier**



## **Iron Rule:**

**"Do unto others before they do it to you."**

## **Silver Rule:**

**"Do unto others as they do unto you."**

## **Golden Rule:**

**"Do unto others as you would have them do unto you."**



**God gave only one rule in the Beginning.**

**How much simpler could it have been?**

**God just wanted a relationship.**

**Breaking the rule broke the relationship,  
and Christ had to come mend it.**

# The Pattern of Things to Come

**The Old Testament was a Pattern  
for the Kingdom to Come**

**It was a basis, not an exact template.  
It was a pattern that helped us learn the Truth.**

**The prophets were also trying to see the new pattern.**

**Christ came to show the perfected pattern**

**Jesus Christ overlaid His Pattern over the Old Testament  
to show the character of the New Kingdom**

# Christ's Interpretation of the Law

**Jesus did not come to free us from the law.  
He came to free us from our sin.**

**"Do not think that I have come  
to abolish the Law or the Prophets;  
I have not come to abolish them but to fulfill them.  
I tell you the truth,  
until heaven and earth disappear,  
not the smallest letter,  
not the least stroke of a pen,  
will by any means disappear from the Law  
until everything is accomplished.**

**Matthew 15:17-18**

**The Bible is not a law book, but a love letter.**

**Ray Marcrom**

**What pattern did Christ see in the Woman at the Well?**

**She had had five husbands,  
but the man she was living with was not her husband.**

**Did He see a Pattern of Desire?**

**We see a pattern of desire for men...**

**Christ saw through the cover-up,  
and saw a pattern of desire for God.**

**Was Christ saying that the law was too restrictive?**

**Or was He just trying to invoke the right interpretation?**

**He wants us all to understand the purpose of the Law:  
It must lead to Good!**

# Consider Paul's thoughts on the Law

**"Everything is permissible" —  
but not everything is beneficial.**

**"Everything is permissible" —  
but not everything is constructive.**

**Nobody should seek his own good,  
but the good of others.**

**Watch out for  
malicious  
compliance!**

**1 Corinthians 6:23-4**

**Was Paul saying that the law was too permissive?  
Can there be things that are lawful but not edifying?  
We know that Grace must not be abused (Romans 6:1)!**

**He **also** wants us all to understand the purpose of the Law:  
It must lead to Good!**

# Paul tried to follow a rigid interpretation of the Law <sup>15</sup>

...we who worship by the Spirit of God,  
who glory in Christ Jesus,  
and who put no confidence in the flesh --  
though I myself have reasons for such confidence.

If anyone else thinks he has reasons  
to put confidence in the flesh, I have more:  
circumcised on the eighth day,  
of the people of Israel,  
of the tribe of Benjamin,  
a Hebrew of Hebrews;  
in regard to the law, a Pharisee;  
as for zeal, persecuting the church;  
as for legalistic righteousness, **faultless**.

Philippians 3:3-6

Paul had the best pedigree a Jew could boast of!

# Paul tried to follow a rigid interpretation of the Law<sup>15</sup>

**But whatever was to my profit**

**I now consider loss for the sake of Christ.**

**What is more,**

**I consider everything a loss**

**The Pearl of  
Great Price  
Matthew 13:45**

**compared to the surpassing greatness  
of knowing Christ Jesus my Lord,**

**for whose sake I have lost all things.**

**I consider them rubbish,**

**that I may gain Christ and be found in him...**

**Philippians 3:7-9**

**The pattern of the perfect Pharisee was not sufficient!**



# **We must learn from these lessons**

**Christ pleaded throughout his life on this earth  
to not be caught up in “Legalism”.**

**He struggled constantly with the Pharisees on this issue.**

**We must get the real message.**

**We must see the Truth clearly.**

**We must not let the church be consumed by  
what Christ died to free us from!**

# Were the Pharisees stupid, or blind?

**Christ did not fit their pattern,  
and they could not accept Him.**

**They had too much time and history  
invested in their old structure.**

**They were blinded by their own perception of the Truth.**

**Should they remodel or rebuild?**

**This is part of the reason for the “mystery”.**

**Satan apparently did not believe that**

**Christ could be raised from the dead,**

**and that His sacrifice could save man from his sins  
and free him from his bondage.**

**Satan saw his victory evaporate in the final seconds.**

# Recovering Pharisee (1)

**I'm a pharisee in recovery**

**With new eyes I can see a big sinner in me**

**But it's the way of my human heart**

**To confess other people's sin,**

**Reluctant to admit my part or the deeper problem within.**

**But, thank God, He won't let me be, or remain in my  
hypocrisy**

**Sooner or later I'll be on my knees**

**Honest to God a recovering Pharisee**

**Words and music by Buddy Greene**

## Recovering Pharisee (2)

**I'm a sinner and a saint simultaneously**

**I'm not what I was or what I'm goin' to be**

**Still I've got that ol' tendency to be all a wicked man can be**

**It takes more than knowin' right from wrong**

**It takes more than singin' gospel songs**

**It takes the life of the Great I Am to produce any good in me**

**He's the Vine I'm the branch and I'm learnin' to be**

**Honest to God, a recovering Pharisee**

# Recovering Pharisee (3)

**I need the God of all grace each and every day**

**If I'm to run his race if I'm to walk in His way**

**I don't have to be a slave to sin I don't have to let the devil  
win**

**Cause the Son of God lives in me and He promises to set  
me free**

**So, Jesus, help my unbelief so I can follow you faithfully**

**You're the Shepherd I'm the sheep and you're helpin' me be**

**Honest to God, a recovering Pharisee**

- Introduction
- The Perception Process
- Pattern Structure
- The Pattern of God's Plan
- **Critical Patterns**
  - Law
  - **Church**
  - Family
  - God's Goodness
  - Personal
- Developing the Pattern God Wants in Us
- Summary

**We are most scandalized  
by sins of the flesh.**

**Jesus was most scandalized  
by sins of the spirit.**

**John Ortberg**



# The Pattern of Worship -- Back to the Tabernacle<sup>16</sup>

This pattern is described in some detail.

Now the first covenant had **regulations for worship** and also an earthly sanctuary.

A tabernacle was set up.

In its first room were the lampstand,  
the table and the consecrated bread;  
this was called the Holy Place.

Behind the second curtain was a room  
called the Most Holy Place,  
which had the golden altar of incense  
and the gold-covered ark of the covenant.

Hebrews 9:1-4a

# The Pattern of Worship -- Back to the Tabernacle<sup>16</sup>

This ark contained the gold jar of manna,  
Aaron's staff that had budded,  
and the stone tablets of the covenant.

Above the ark were the cherubim of the Glory,  
overshadowing the atonement cover.

**But we cannot discuss these things in detail now.**

**Hebrews 9:4b-5**

**How important is it that the crucial elements kept in the ark  
were lost forever?**

**How did they worship without them?**

**Were they not a part of the pattern?**

**They worshiped God without them.**

# **The Pattern of Worship -- Back to the Tabernacle<sup>16</sup>**

**How could the Israelites do without the critical physical elements of the old worship system?**

- 1) pillar of cloud and fire gone,**
- 2) fire on the altar extinguished,**
- 3) ark no longer had its special contents,**
- 4) eventually the ark itself is gone**
- 5) the temple was destroyed  
(and the older people cried at its replacement)**
- 6) the veil of the temple was ripped in two to expose the Most Holy Place [Ron]**

**The woman at the well also was concerned about the “place” of worship.**

**Jesus wants worship in spirit and in truth!**

# The Pattern of Worship -- Back to the Tabernacle<sup>16</sup>

**When everything had been arranged like this,  
the priests entered regularly into the outer room  
to carry on their ministry.**

**But only the high priest entered the inner room,  
and that only once a year,  
and never without blood,  
which he offered for himself  
and for the sins the people  
had committed in ignorance.**

**Tradition: a rope attached  
to the leg of the High  
Priest in case he fell ill**

**Hebrews 9:6-7**

**The tabernacle pattern prepared the way  
for the new, spiritual pattern.**

# The Pattern of Worship -- Back to the Tabernacle<sup>16</sup>

The Holy Spirit was showing by this that **the way into** the Most Holy Place had not yet been disclosed as **long as the first tabernacle was still standing.**

The old pattern blocked the way

This is an illustration for the present time, indicating that the gifts and sacrifices being offered were not able to clear the conscience of the worshiper.

They are only a matter of food and drink and various ceremonial washings — **external regulations** applying until the time of the new order.

Regulated worship

Hebrews 9:8-10

The old pattern was clearly not sufficient for True Worship.

# **The Pattern of Worship -- Back to the Tabernacle**

**When Christ came as high priest  
of the good things that are already here,  
he went through the greater  
and more perfect tabernacle  
that is not man-made,  
that is to say, not a part of this creation.**

**The old pattern was  
only sufficient to roll the  
problem forward**

**He did not enter by means  
of the blood of goats and calves;  
but he entered the Most Holy Place once for all  
by his own blood,  
having obtained eternal redemption...  
so that we may serve the living God!**

**The “dirt” was  
never removed**

**Hebrews 9:11-14**

**Christ re-wrote the pattern into something more effective.**

# The Pattern of Worship -- Back to the Tabernacle<sup>16</sup>

When Moses had proclaimed

**every commandment of the law** to all the people,  
he took the blood of calves, together with water...  
and sprinkled the scroll and all the people.

He said,

"This is **the blood of the covenant**,  
which God has commanded you to keep."

Jesus: similar word  
at the Last Supper

In the same way,

he sprinkled with the blood both the tabernacle  
and everything used in its ceremonies.

In fact, the law requires that nearly everything  
be cleansed with blood,  
and without the shedding of blood  
there is no forgiveness.

Hebrews 9:18-22

# The Pattern of Worship -- Back to the Tabernacle<sup>16</sup>

It was necessary, then,  
for the **copies** of the heavenly things  
to be purified with these sacrifices,  
but the heavenly things themselves  
with **better** sacrifices than these.

For Christ did not enter a man-made sanctuary  
that was only a **copy** of the true one;  
he entered heaven itself,  
now to appear for us in God's presence.

The Holiest of  
the Holiest

... now he has appeared **once for all** at the end of the ages  
to do away with sin by the sacrifice of himself.

Hebrews 9:23-26

The new pattern clarifies how we conduct True Worship.



**Losing an illusion makes you wiser  
than finding a truth.**

**Ludwig Borne**

# **The Pattern of Worship -- Back to the Tabernacle<sup>17</sup>**

**How could the Israelites do without the critical physical elements of the old worship system?**

- 1) pillar of cloud and fire gone,**
- 2) fire on the altar extinguished,**
- 3) ark no longer had its special contents,  
(only the two stone tablets in 1 Kings 8:9)**
- 4) eventually the ark itself is gone,**
- 5) the temple was destroyed,  
(and the older people cried at its replacement)**
- 6) the veil of the temple was ripped in two to expose the  
Most Holy Place [Ron]**

**The woman at the well also was concerned about the  
“place” of worship.**

**Jesus wants worship in spirit and in truth!**

# **David's Pattern of Worship -- with the Tabernacle<sup>17</sup>**

**How David express his joy over God's presence?**

**So David went down and brought up the ark of God  
from the house of Obed-Edom  
to the City of David with rejoicing...**

**David, wearing a linen ephod,  
danced before the LORD with all his might,  
while he and the entire house of Israel  
brought up the ark of the LORD with shouts  
and the sound of trumpets.**

**2 Samuel 6:12-15**

**We were brought up without clapping our hands, etc.  
And we certainly would not be caught dancing!**

**The type of Judaism in which Paul had grown up had become largely traditional:**

**The word of the Lord, the Rabbis held,  
came to the prophets of old,  
but we can only preserve and interpret  
the truth they handed down.**

**Jesus Christ, with a confidence  
that to the timid traditionalism of His time  
appeared blasphemous,  
asserted that He knew the Father  
and was prepared to let others into that knowledge.**

**He did so,  
not by handing down a new tradition about God,  
but by making others sharers  
in His own attitude to God.**

**This is what Paul means by  
"having the mind of Christ."**

**C. Harold Dodd**

**We must not let the church be consumed by  
what Christ died to free us from!**

**Christianity is based on an ordered pattern.**

**Ed Wharton**

**Further discussion can be found in his book,  
The Church of Christ**

**How absolute is this pattern?**

**How well does it establish  
the True Identity of the Church?**

**We will be thinking about the True Pattern of the Church.**

# The Pattern of Worship

**Is there a scriptural order?**

**Or is it merely a traditional order?**

**Two songs and a prayer, etc.**

**Is there a scriptural time?**

**start time**

**length of service**

**Can you worship without the minister?**

**being late to Gnat Hill**

**is the sermon more important than the Communion?**

**Can you use an alternate translation?**

**the KJV Baptist Church near Huntsville**

**We advertise New Testament Christianity,  
but are we more set in our own interpreted traditions?**

# The Pattern of Worship

**This is a New Testament Example --  
Do we follow it?**

**When you come together,  
everyone has a hymn,  
or a word of instruction,  
a revelation,  
a tongue  
or an interpretation.**

Or a dance?

**All of these must be done  
for the strengthening of the church.**

**1 Corinthians 14:26**



**This is a New Testament Example --  
Do we follow it?**

**If anyone speaks in a tongue, two  
— or at the most three —  
should speak,  
one at a time,  
and someone must interpret.**

**If there is no interpreter,  
the speaker should keep quiet in the church  
and speak to himself and God.**

**1 Corinthians 14:27-28**

# The Pattern of Worship

**This is a New Testament Example --  
Do we follow it?**

**Two or three prophets should speak,  
and the others should weigh carefully what is said.**

**And if a revelation comes**

**to someone who is sitting down,  
the first speaker should stop.**

**For you can all prophesy in turn so that everyone  
may be instructed and encouraged...**

**For God is not a God of disorder but of peace.**

**1 Corinthians 14:29-33**

# The Pattern of Worship / Service

**This is a Pre- New Testament Church Example --  
Do we follow it?**

**It was just before the Passover Feast...**

**Jesus... got up from the meal,  
took off his outer clothing,  
and wrapped a towel around his waist.**

**After that, he poured water into a basin  
and began to wash his disciples' feet,  
drying them with the towel  
that was wrapped around him.**

**1 Corinthians 14:29-33**

**Is this an act of service, or worship, or both?  
Is this pattern essential, good to do, or just historical?**

**Does merely following the pattern  
make us True Christians?**

**Sitting in a church  
doesn't make you a Christian  
any more than sitting in a hen house  
makes you a chicken.**

**Ray Marcrom**

**We must worship / serve from the heart.**

## Applying it to other areas of life.

**Why do we not have denominationalist patterns for our home relationships that set us apart from each other proscribed singing of songs to each other, acts of service (taking out the garbage, washing the dishes, dusting, mowing the lawn, etc.) at particular times or in a particular sequence –**

**Though these items might help our relationship, the forced (and arbitrary) order of them would not;**

**Acts of love (or worship) must come from the heart and as such are many times spontaneous.**

**Today, someone has remarked,  
it takes 3000 sermons to convert one person,  
just the reverse of the New Testament pattern.**

# Dancing for Joy!

How David express his joy over God's presence?



293



292



293

*top row*



294



295



DANCE

Sometimes we can't keep from expressing ourselves!

When denominations and other religious organizations become established, their theologies and social structures tend to be **rigid**.

Anyone with fresh insight or a prophetic word is stoned verbally or excluded from the Jerusalem (headquarters) of the group.

Only those who fit the prescribed **pattern** survive.

Gayle Erwin

Is our church a fortress or a prison?



# **The Crystallization of Active Organizations**

**Sometimes in life we find ourselves in a similar situation, being damaged by the very structure that is supposed to give us shelter and stability.**

**Unfortunately, the church (as implemented in the hands of men) can have this reversed function.**

**The church is an institution ordained by God and if operated according to his pattern, it is indeed the body of Christ.**

**The only thing that can go wrong with it stems from the failings of the sinners (you and me) who are a part of it.**

**If you have ever worked within its structure, you have most likely crashed into it at least once.**

# The Restoration of Art and other things

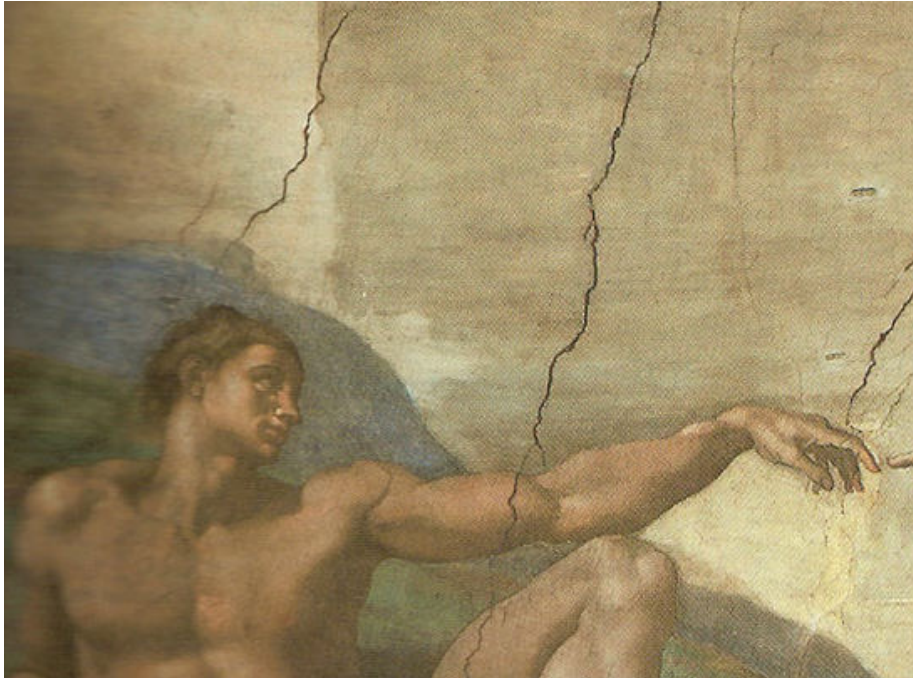

**The true church is an original painting  
that has been painted over  
and must be carefully restored to be revealed.**

**Do we go back to reveal the  
external pattern of the worship service,  
or the internal pattern of worship from the heart**

# **We must not get misled by a different pattern**

**I am astonished that you are **so quickly**  
deserting the one who called you  
by the grace of Christ  
and are turning to a different gospel —  
which is really no gospel at all.**

**Evidently some people are throwing you into confusion  
and are trying to pervert the gospel of Christ.**

**But even if we or an angel from heaven  
should preach a gospel  
other than the one we preached to you,  
let him be eternally condemned!**

**As we have already said, so now I say again:**

**If anybody is preaching to you a gospel  
other than what you accepted,  
let him be eternally condemned!**

**Galatians 1:6-9**

# We must not get misled by a different pattern

For if someone comes to you  
and preaches a **Jesus**  
other than the Jesus we preached,  
or if you receive a different **spirit**  
from the one you received,  
or a different **gospel** from the one you accepted,  
you put up with it easily enough.

2 Corinthians 11:4

**We are too easily distracted!**

# The tendency is to split when there are different views

## Major branches within Christianity

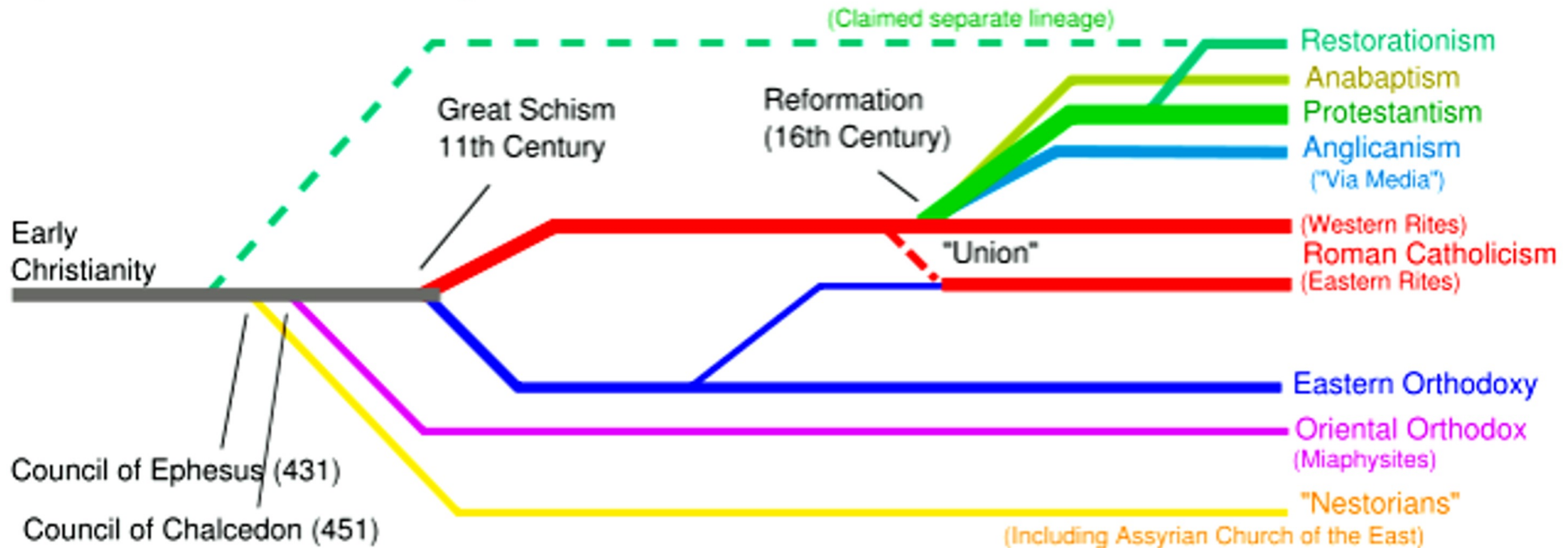

**We must live in harmony with our differences.**

# Perspective: Seeing things differently



© 1970 United Feature Syndicate, Inc.



**God is not disillusioned with us.  
He never had any illusions to begin with.**

**Luis Palau**

## **Sometimes we are more comfortable with a strict structure around us.**

**All the Israelites grumbled against Moses and Aaron,  
and the whole assembly said to them,**

**"If only we had died in Egypt! Or in this desert!**

**Why is the LORD bringing us to this land  
only to let us fall by the sword?**

**Our wives and children will be taken as plunder.**

**Wouldn't it be better for us to **go back to Egypt?**"**

**And they said to each other,**

**"We should choose a leader and **go back to Egypt.**"**

**Numbers 14:2-4**

**We don't want to go back to a state of bondage.**



## **Is it the external structure that is sacred, or the spirit that fills it?**

**"No one sews a patch of unshrunk cloth  
on an old garment,  
for the patch will pull away from the garment,  
making the tear worse.**

**Neither do men pour new wine into old wineskins.  
If they do, the skins will burst, the wine will run out  
and the wineskins will be ruined.**

**No, they pour new wine into new wineskins,  
and both are preserved."**

**cocoon?**

**Matthew 9:16-17**

**It was hard for the Jews to change  
from the structure of laws that they had grown up with.  
They were more comfortable with the old structure.**

# The tendency is to split when there are different views

## Major branches within Christianity

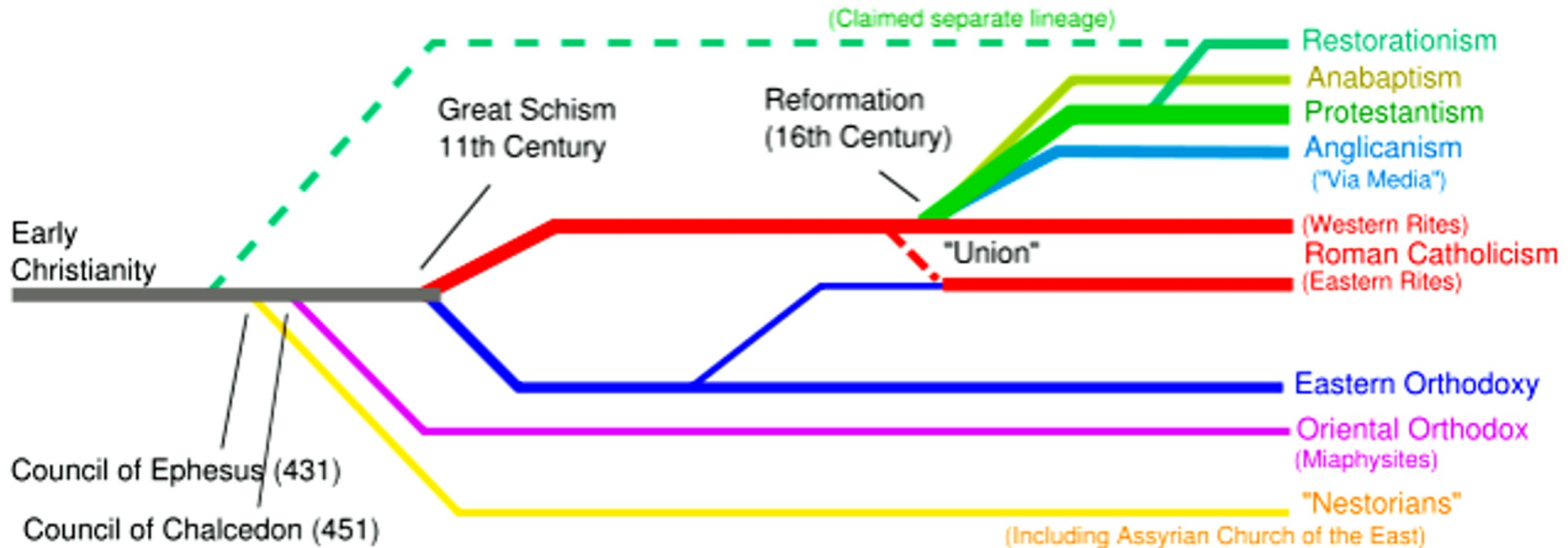

**We see self-imposed blemishes on the body of Christ.**

**We must live in harmony with our differences.**

# Persecution makes the church stronger or weaker? <sup>19</sup>

Figure 14-1. U.S. Defense Aerospace Industry Consolidation, 1980-1997

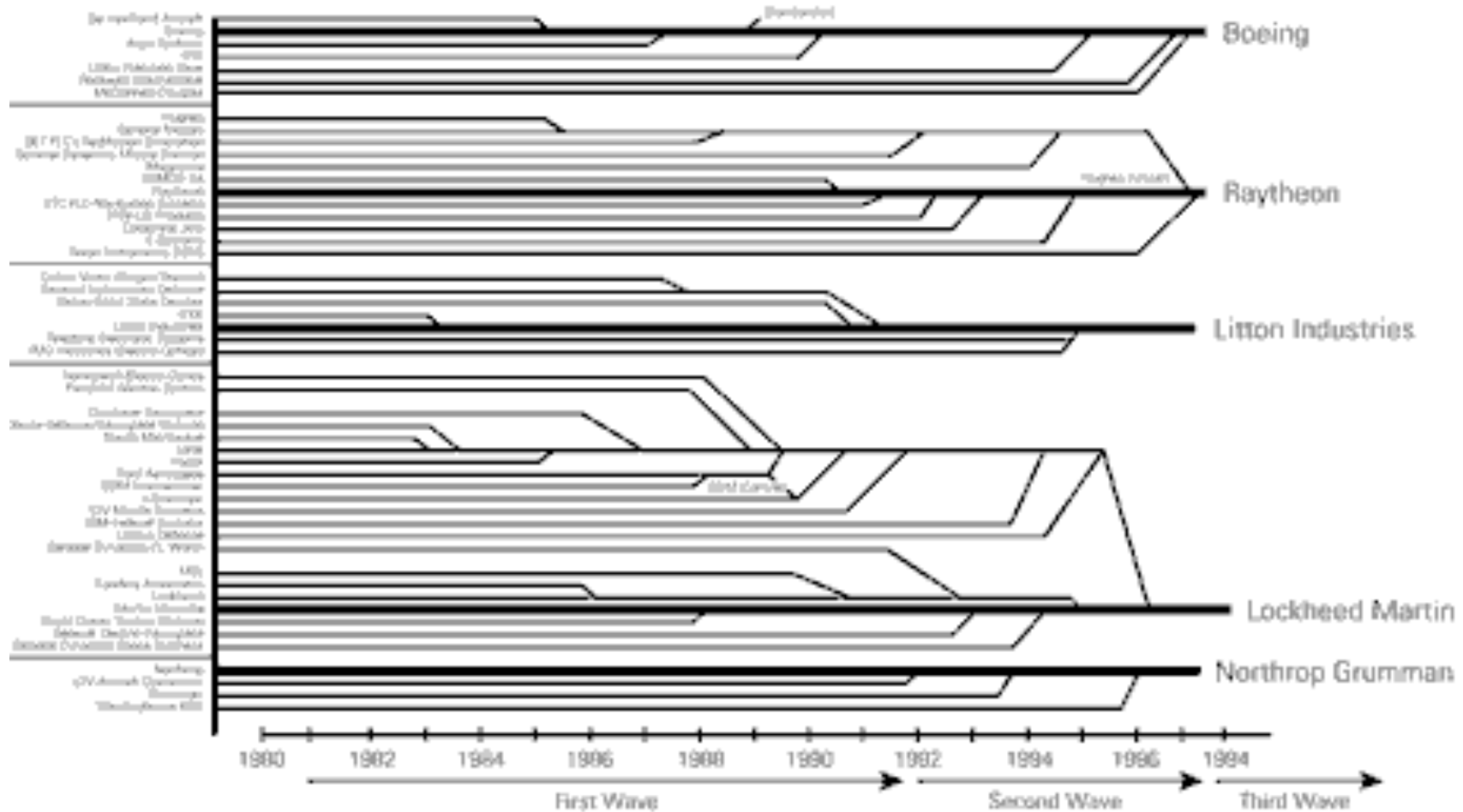

Source: Credit Suisse First Bank data as reported by Defense Science Board, May 1997

**Hardship can drive consolidation.**

## **Different Altar (pattern)**

**Look back to the early days of Israel, as they spread out. Joshua praised the tribes who chose east of the Jordan and had agreed to fight alongside the other tribes**

**"You have done all that Moses the servant of the LORD commanded, and you have obeyed me in everything I commanded.**

**For a long time now — to this very day — you have not deserted your brothers but have carried out the mission the LORD your God gave you.**

**Now that the LORD your God has given your brothers rest as he promised, return to your homes in the land that Moses the servant of the LORD gave you on the other side of the Jordan.**

**Joshua 22:1-4**

**But be very careful**

**to keep the commandment and the law  
that Moses the servant of the LORD gave you:**

**to love the LORD your God,**

**to walk in all his ways,**

**to obey his commands,**

**to hold fast to him and**

**to **serve him with all your heart and all your soul.****”

**Then Joshua blessed them and sent them away,  
and they went to their homes.**

**Joshua 22:5-6**

**The True Pattern is to Love and to Serve**

## **Different Altar (pattern)**

**When they came... near the Jordan in the land of Canaan,  
the Reubenites, the Gadites  
and the half-tribe of Manasseh  
built an imposing altar there by the Jordan.**

**And when the Israelites heard  
that they had built the altar  
on the border of Canaan at Geliloth  
near the Jordan on the Israelite side,  
the whole assembly of Israel gathered at Shiloh  
to go to war against them.**

**Joshua 22:10-12**

**Ready for war at the appearance of a different pattern!**

## Different Altar (pattern)

**"The whole assembly of the LORD says:**

**'How could you **break faith****

**with the God of Israel like this?**

**How could you turn away from the LORD**

**and build yourselves an altar**

**in rebellion against him now?**

**Was not the sin of Peor enough for us?**

**Up to this very day we have not cleansed ourselves**

**from that sin,**

**even though a plague**

**fell on the community of the LORD!**

**And are you now turning away from the LORD ?**

**Joshua 22:16-18**

**The other tribes were worried...**

## **Different Altar (pattern)**

**'If you rebel against the LORD today,  
tomorrow he will be angry  
with the whole community of Israel.**

**... do not rebel against the LORD  
or against us  
by building an altar for yourselves,  
other than the altar of the LORD our God.**

**When Achan son of Zerah acted unfaithfully  
regarding the devoted things,  
did not wrath come upon  
the whole community of Israel?**

**He was not the only one who died for his sin.'  
Joshua 22:16-18**

**... about themselves!**



**The tribes respond:**

**"The Mighty One, God, the LORD!**

**The Mighty One, God, the LORD! He knows!**

**And let Israel know!**

**If this has been in rebellion or disobedience to the LORD,  
do not spare us this day.**

**If we have built our own altar to turn away from the LORD  
and to offer burnt offerings and grain offerings,  
or to sacrifice fellowship offerings on it,  
may the LORD himself call us to account.**

**Joshua 22:19-24**

**They call God as witness to their story**

## Different Altar (pattern)

They were concerned about the natural boundary of the Jordan isolating them from the other tribes.

"That is why we said,  
'Let us get ready and build an altar —  
but not for burnt offerings or sacrifices.'

On the contrary, it is to be a **witness**  
between us and you and the generations that follow,  
that we will worship the LORD at his sanctuary  
with our burnt offerings,  
sacrifices and fellowship offerings.

Joshua 22:19-24

Their altar is a replica of the Lord's altar -- to remind them.

# Different Altar (pattern)

**The other tribes were satisfied with the reason.**

**And the Reubenites and the Gadites  
gave the altar this name:**

**A Witness Between Us that the LORD is God.**

**Joshua 22:19-24**

**We must be careful not to jump to conclusions  
about the pattern that people embrace.**

# We have to look beyond the shadow to the True pattern

Therefore do not let anyone judge you  
by what you eat or drink,  
or with regard to a religious festival,  
a New Moon celebration or a Sabbath day.

These are a **shadow** of the things that were to come;  
the **reality**, however, is found in Christ.

Colossians 2:16ff

**We are not good at waiting until the shadow is passed!**

**Lord, help me to do great things  
as though they were little,  
since I do them with your power;  
and little things as though they were great,  
since I do them in your name.**

**Blaise Pascal**

# We have to look beyond the shadow to the True pattern

Therefore do not let anyone judge you  
by what you eat or drink,  
or with regard to a religious festival,  
a New Moon celebration or a Sabbath day.

These are a **shadow** of the things that were to come;  
the **reality**, however, is found in Christ.

Colossians 2:16ff

**We are not good at waiting until the shadow is passed!**

**How far would you go (what would you do)  
to be with someone you loved?**

**The Trinity Baptist Praise Band**

**True Love pushes us through the Shadow.**

# Applying Patterns: Paul at Lystra

**In Lystra Paul healed a man crippled in his feet  
(lame from birth)**

**When the crowd saw what Paul had done,  
they shouted in the Lycaonian language,  
"The gods have come down to us in human form!"**

**Barnabas they called Zeus, and Paul they called Hermes  
because he was the chief speaker.**

**The priest of Zeus,  
whose temple was just outside the city,  
brought bulls and wreaths to the city gates  
because he and the crowd wanted  
to offer sacrifices to them.**

**Acts 14:11-13**



# Applying Patterns

**But when the apostles Barnabas and Paul heard of this,  
they tore their clothes  
and rushed out into the crowd, shouting:**

**"Men, why are you doing this?**

**We too are only men, human like you.**

**We are bringing you **good news**,**

**telling you to turn from these worthless things  
to the living God,**

**who made heaven and earth and sea  
and everything in them...**

**Even with these words,  
they had difficulty keeping the crowd  
from sacrificing to them.**

**Acts 14:11-18**

**The people tried to apply their religious “pattern” to them.**

**Peter saw the new pattern,  
but he could not grasp all of it;  
his view was narrow (only the Jews),  
and had to be pushed  
into the acceptance of the Gentiles (blanket);  
even then he could not see it as clearly as Paul.**

- Introduction
- The Perception Process
- Pattern Structure
- The Pattern of God's Plan
- **Critical Patterns**
  - Law
  - Church
  - Family and others
  - **God's Goodness**
  - Personal
- Developing the Pattern God Wants in Us
- Summary

**When Jesus heard that John had been put in prison, he returned to Galilee... to fulfill what was said through the prophet Isaiah:**

**"Land of Zebulun and land of Naphtali,  
the way to the sea, along the Jordan,  
Galilee of the Gentiles—  
the people living in darkness  
have seen a great light;  
on those living in the land of the shadow of death  
a light has dawned."**

**From that time on Jesus began to preach,  
"Repent, for the kingdom of heaven is near."**

**Matthew 4:12-17**

**The powerful light of God's Truth must dawn on us.**

# Seeing the Pattern of God's Goodness



**We must be able to see (and be awed by) the Core.**

# Seeing the reality of God (1)

**When we see through the camouflage haze  
that at times convinces us  
that only the material exists,  
when we touch that consciousness,  
we know it.**

**A joyful rush of emotion sweeps over the entire self.**

**This emotional response –  
some might call it a religious experience –  
is reported in every culture,  
from every period.**

**It tells us that we've come home.**

## Seeing the reality of God (2)

**We've discovered the essence of being.**

**Everyone has felt it at some time or other.**

**Perhaps at a brilliant sunrise,  
in a work of art,  
the words of a loved one.**

**The physical and the metaphysical have joined.**

**If we dared,  
we'd call the experience spiritual,  
even Godly.**

## Seeing the reality of God (3)

**But there's a reluctance to use the "G" word.**

**"Listen to the Force" is acceptable  
on the great silver screen.**

**If the Star Wars scriptwriter had used "Listen to God,"  
the theater would have emptied in a flash.**

**... A bit of scrutiny reveals that most of those claims  
are based on the expectations for the putative  
(and generally misunderstood)  
God of the Bible that we learned as children.**

**Gerald Schroeder**

**Children will absorb ideas until their minds close (art, etc)**



# God is the Perfect Pattern of Goodness

**And we must match everything we see  
against that pattern.**

**That vision must comprehend the value  
of the Total Goodness of God  
(no matter what happens to us in life)**

**see Job**

**We must believe in that Goodness with all of our hearts;  
we must become totally immersed in it.**

**With the pattern that we have chosen,  
do Goodness and Light always show through?**

**Do you use a pattern that blocks out all of the light?**

# Always search for the Good

**Finally, brothers,  
whatever is true,  
whatever is noble,  
whatever is right,  
whatever is pure,  
whatever is lovely,  
whatever is admirable —**

**if anything is excellent or praiseworthy —  
think about such things.**

**Philipians 4:8**

**The critical part of the Pattern is: Love for all!**

# **The Creation itself rejoices in awe**

**Let the heavens rejoice, let the earth be glad;  
let them say among the nations, "The LORD reigns!"**

**Let the sea resound, and all that is in it;  
let the fields be jubilant, and everything in them!**

**Then the trees of the forest will sing,  
they will sing for joy before the LORD,  
for he comes to judge the earth.**

**Give thanks to the LORD, for he is good;  
his love endures forever.**

**1 Chronicles 16:31-34**

**We are supposed to be the “smart” part of His creation**

# Jesus used parables to show us the Pattern

**The Kingdom of Heaven is like...**

**a man who sowed good seed in his field [Weeds]; 24**

**a mustard seed which a man took and planted in his field [Mustard Seed]; 32**

**yeast that a woman took and mixed into a large amount of flour until it worked all through the dough [Yeast]; 34**

**treasure hidden in a field [Hidden Treasure]; 43**

**a merchant looking for fine pearls [Pearl]; 44**

**a net that was let down into the lake and caught all kinds of fish [Net]; 46**

**Matthew 13**

**All of these images are found in Matthew**

# Jesus used parables to show us the Pattern

**The Kingdom of Heaven is like...**

**this child is the greatest in the kingdom of heaven; 18:4**

**a king who wanted to settle accounts with his servants;**

**18:22**

**a landowner who went out early in the morning to hire men to work in his vineyard**

**[The Workers in the Vineyard ]; 20:1**

**a king who prepared a wedding banquet for his son;**

**22:2**

**Matthew 18, 20, 22**

**He was trying to weave a Pattern  
to enable us to see the Truth**

# Jesus used parables and stories to show us the Pattern

- the parable of the Good Samaritan
- the story of the widow and her two mites
- the illustration of the rich man and the eye of a needle
- the story of the rich man and Lazarus
- the parable of the wise and foolish builders
- the parable of the sower

the parables and stories were 'perception tests'

**It seems that we have difficulty  
handling anything that we cannot  
ritualize,  
program,  
put in a pattern,  
or over-simplify.**

**Cecil Hook**

- **Law**
- **Church**
- **Family and others**
- **God's Goodness**
  - **Overwhelming and Awesome**
  - **Jesus painted pictures to show us the Pattern**
  - **The Law is Good, but is the Law absolute?**
  - **Examine the depth of the Pattern**
  - **Jesus is the Image of the Pattern of Truth (God)**
  - **We must match the image of Christ**
  - **Following examples of Christ**
  - **How good do we fit the Pattern?**
- **Personal - Patterning ourselves after God**



# Jesus used parables and stories to show us the Pattern

- the parable of the Good Samaritan
- the story of the widow and her two mites
- the illustration of the rich man and the eye of a needle
- the story of the rich man and Lazarus
- the parable of the wise and foolish builders
- the parable of the sower

the parables and stories were 'perception tests'

- Law
- Church
- Family and others
- **God's Goodness**
  - Overwhelming and Awesome
  - Jesus painted pictures to show us the Pattern
  - **The Law is Good, but is the Law absolute?**
  - Examine the depth of the Pattern
  - Jesus is the Image of the Pattern of Truth (God)
  - We must match the image of Christ
  - Following examples of Christ
  - How good do we fit the Pattern?
- Personal - Patterning ourselves after God

# **This Pattern includes the Law**

**We know that the law (pattern) is good  
if one uses it properly.**

**1 Timothy 1:8**

**We must understand how to use the law for Good.**

# David saw the Good in the Pattern of the Law

21

**To all perfection I see a limit;  
but your commands are boundless.**

**Oh, how I love your law!  
I meditate on it all day long.**

**Psalms 119:96-97**

**Can we see it?**

# How Absolute is the Pattern of the Law (1)?

**I warn everyone who hears  
the words of the prophecy of this book:**

**If anyone adds anything to them,  
God will add to him the plagues described in this book.**

**And if anyone takes words away  
from this book of prophecy,  
God will take away from him his share  
in the tree of life and in the holy city,  
which are described in this book.**

**Revelation 22:18-19**

**God wants us to treat His Law with Respect!**

# How Absolute is the Pattern of the Law (2)?

**Do not add to what I command you  
and do not subtract from it,  
but keep the commands of the LORD your God  
that I give you.**

**Deuteronomy 4:2**

**The original Pattern was not sacred,  
because God changed it.  
The underlying foundation of love is!**

# How exact must our interpretation be?

**Consider a package of “identical” items  
like nuts and bolts.**

**How far do we examine them  
to find out if they fit the pattern exactly?**

**How much deviation can we stand  
and still be able to use them?**

**How closely do we examine ourselves, or others?**

**The Pharisees spent all of their time  
checking the parts  
and not actually seeing if they worked  
(or doing/making anything useful with them  
They didn't see the tolerance God gives us.**

- Law
- Church
- Family and others
- **God's Goodness**
  - Overwhelming and Awesome
  - Jesus painted pictures to show us the Pattern
  - The Law is Good, but is the Law absolute?
  - **Examine the depth of the Pattern**
  - Jesus is the Image of the Pattern of Truth (God)
  - We must match the image of Christ
  - Following examples of Christ
  - How good do we fit the Pattern?
- Personal - Patterning ourselves after God



# Consider again the structure of the law

**Example: Thou shall not commit adultery**

**What is the reason for this commandment?**

**Is it enough to prevent this sinful activity?**

**Or is it meant to be part of  
a structure of faithfulness  
that eliminates the desire to sin?**

**Remember Matthew 5:28ff  
(if you lust, you have already committed adultery)**

**We need to view the law in terms of the overall picture**

# Growing our Comprehension of the Pattern

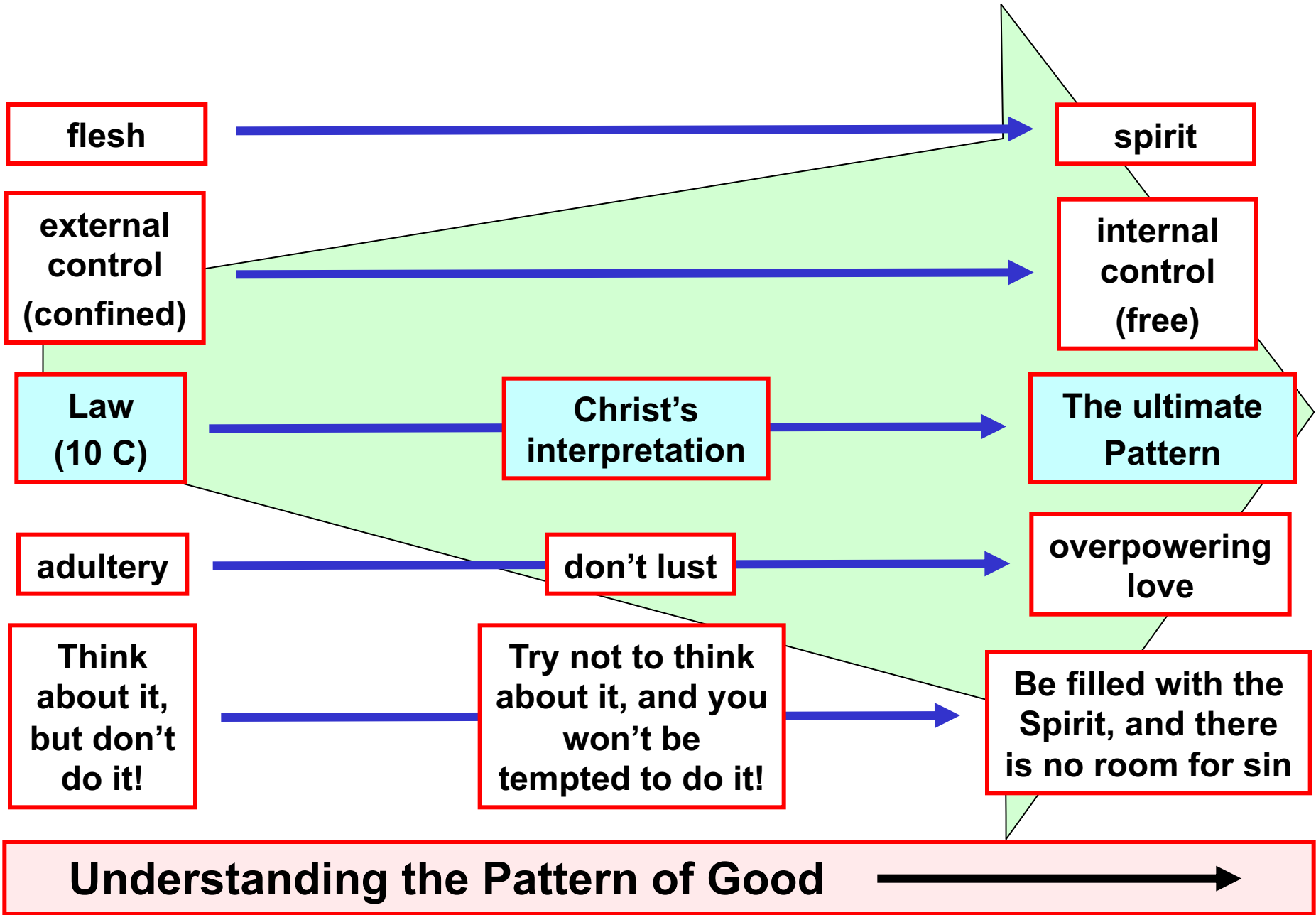

# Representations

bumper cars

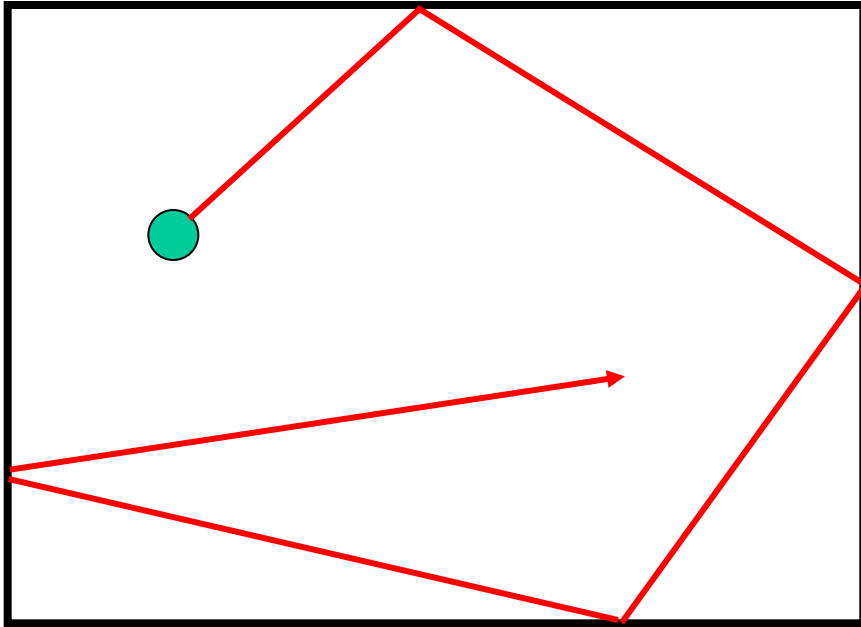

Law  
(10 C)

external  
control  
(confined)

driving a real car

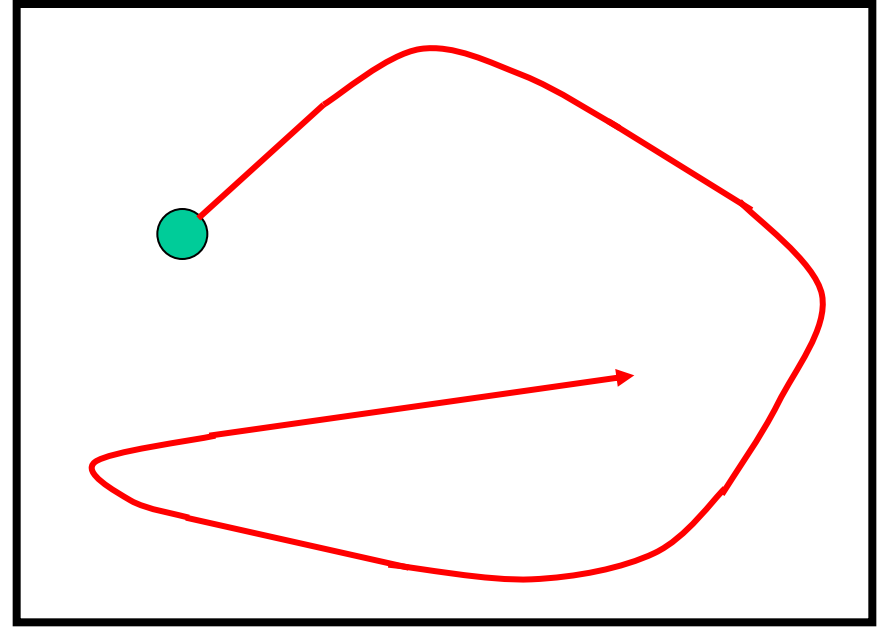

the ultimate  
Pattern

internal  
control  
(free)

Constraint versus Freedom

# **Are we controlled by the law or by the Spirit?**

**Those who live according to the sinful nature  
have their minds set on what that nature desires;  
but those who live in accord with the Spirit  
have their minds set on what the Spirit desires.**

**The mind of sinful man is death,  
but the mind controlled by the Spirit is life and peace;  
Those controlled by the sinful nature cannot please God.**

**You, however, are controlled not by the sinful nature  
but by the Spirit, if the Spirit of God lives in you...**

**Romans 8:5-9**

**The Spirit of God must be our driving force**

# The Temptations of Jesus

**When Jesus was tempted,  
he used the structure of the Law and Scripture  
to argue with Satan,  
but he was not constrained by it.**

**The real reason for His behavior was  
that he was filled with Good.**

**There isn't any symbolism.**

**The sea is the sea.**

**The old man is an old man.**

**The boy is a boy and the fish is a fish.**

**The shark are all sharks no better and no worse.**

**All the symbolism that people say is \_\_\_\_.**

**Ernest Hemingway**

- Law
- Church
- Family and others
- **God's Goodness**
  - Overwhelming and Awesome
  - Jesus painted pictures to show us the Pattern
  - **The Law is Good, but is the Law absolute?**
  - Examine the depth of the Pattern
  - Jesus is the Image of the Pattern of Truth (God)
  - We must match the image of Christ
  - Following examples of Christ
  - How good do we fit the Pattern?
- Personal - Patterning ourselves after God

# **The True Pattern lies behind the Presentation**

**The patterns God has shown**

**(Old Testament Law, New Testament Grace)**

**are but projections of the complete picture that God considers that we can absorb at the time.**

**They are such as they are to help us understand.**

**God is so much more infinite than we can grasp.**

**Remember that the Holiest of Holies lies behind the veil**



# **We only see the shadow of God**

**Plato likened our perception of life  
to persons viewing shadows on a wall  
while unaware of the far grander reality  
that produces those shadows.**

**Gerald Schroeder**

**But we will eventually see His reality in full**

- Law
- Church
- Family and others
- **God's Goodness**
  - Overwhelming and Awesome
  - Jesus painted pictures to show us the Pattern
  - The Law is Good, but is the Law absolute?
  - **Jesus is the Image of the Pattern of Truth (God)**
  - We must match the image of Christ
  - Following examples of Christ
  - Examine the depth of the Pattern
  - How good do we fit the Pattern?
- Personal - Patterning ourselves after God

# **Jesus Christ is the Reflection of the True Good** <sup>22</sup>

**He is the image of the invisible God,  
the firstborn over all creation.**

**For by him all things were created:  
things in heaven and on earth,  
visible and invisible,  
whether thrones or powers or rulers or authorities;  
all things were created by him and for him.**

**He is before all things, and in him all things hold together.  
Colossians 1:15-17**

# **Jesus Christ is the Reflection of the True Good** <sup>22</sup>

**And he is the head of the body, the church;  
he is the beginning  
and the firstborn from among the dead,  
so that in everything he might have the supremacy.**

**For God was pleased to have all his fullness dwell in him,  
and through him to reconcile to himself all things,  
whether things on earth or things in heaven,  
by making peace through his blood,  
shed on the cross.**

**Colossians 1:18-20**

**Christ is fully representative of God's Goodness**

# Jesus Christ is the Projection of Good on Earth <sup>22</sup>

**The Son is the radiance of God's glory  
and the **exact representation** of his being,  
sustaining all things by his powerful word.**

**Hebrews 1:3**

**Christ projects the complete Pattern of God**

# Tree Leaf Pinholes Image a Solar Eclipse



**It takes a pinhole – something very small (humility); a big hole will not image**

**We should each image the glory of Christ**

- Law
- Church
- Family and others
- **God's Goodness**
  - Overwhelming and Awesome
  - Jesus painted pictures to show us the Pattern
  - The Law is Good, but is the Law absolute?
  - Examine the depth of the Pattern
  - Jesus is the Image of the Pattern of Truth (God)
  - **We must match the image of Christ**
  - Following examples of Christ
  - How good do we fit the Pattern?
- Personal - Patterning ourselves after God

# Jesus Christ is in the likeness (pattern) of man and God

Who, being in very nature God,  
did not consider **equality with God**  
something to be grasped,  
but made himself nothing,  
taking the very nature of a servant,  
being made **in human likeness**.

And being found in appearance as a man,  
he humbled himself and became obedient to death --  
even death on a cross!

Philipians 2:6-8



# **Jesus Christ bridges the gap between man and God**

**In short, the Man Christ Jesus  
has the decisive place  
in man's ageless relationship with God.**

**He is what God means by 'Man'.**

**He is what man means by 'God'.**

**J. S. Whale**

# We must match His Good Pattern

**And we,**

**who with unveiled faces all reflect the Lord's glory,**

**are being transformed **into his likeness****

**with ever-increasing glory,**

**which comes from the Lord, who is the Spirit.**

**2 Corinthians 3:8**

# If we worship God, we will want to be like Him 22

**Be imitators of God,  
therefore, as dearly loved children  
and **live a life of love**,  
just as Christ loved us  
and gave himself up for us  
as a fragrant offering and sacrifice to God.**

**Ephesians 5:1**

**We Orientals find beauty  
not only in the thing itself  
but in the pattern of the shadows,  
the light and darkness which that thing provides.**

**Junichiro Tanizaki**

- **Law**
- **Church**
- **Family and others**
- **God's Goodness**
  - **Overwhelming and Awesome**
  - **Jesus painted pictures to show us the Pattern**
  - **The Law is Good, but is the Law absolute?**
  - **Examine the depth of the Pattern**
  - **Jesus is the Image of the Pattern of Truth (God)**
  - **We must match the image of Christ**
  - **Following examples of Christ**
  - **How good do we fit the Pattern?**
- **Personal - Patterning ourselves after God**

# If we worship God, we will want to be like Him

**All you need  
to be a superhero  
(or a princess)  
is a towel.**

**Christ was a hero  
with a towel as well  
(see John 13).**



# Image is Everything

**Man was made in the image of God (Genesis 1:26-27, 9:6),  
and we must strive to keep that image.**

**We must find out what God really wants.**

**We must be in the correct Pattern in His eyes.**

**We must fit into the background of His Goodness.**

**We must love the Pattern of Good.**

**Christ reflected God's glory,  
and we must reflect it as well.**

# The Image of God

... the root meaning of the Hebrew word for **image**,  
which modifies the word **likeness**  
in the biblical text (Gen 1:26).

That meaning is “**shadow**.”

Man is indeed intended to present a **likeness** of God.

But the **likeness** is not physical.

It is the **projection** of God's acts  
as they appear in this world,  
God's **shadow** as it were.

We are obliged to **emulate** God  
as we perceive God's interactions  
projected within our world.

Gerald Schroeder



# **If we want to be like God, we will want to follow Christ**

**Then said Jesus unto his disciples,  
If any man will come after me,  
let him deny himself,  
and take up his cross,  
and follow me.**

**Matthew 16:24**

# Christ is the Way (the Pattern) to Follow

**Jesus answered,**

**"I am the **way** and the truth and the life.**

**No one comes to the Father except through me.**

**If you really knew me,**

**you would know my Father as well.**

**From now on, you do know him and have seen him."**

**John 14:6-7**

# The Beauty of Christ

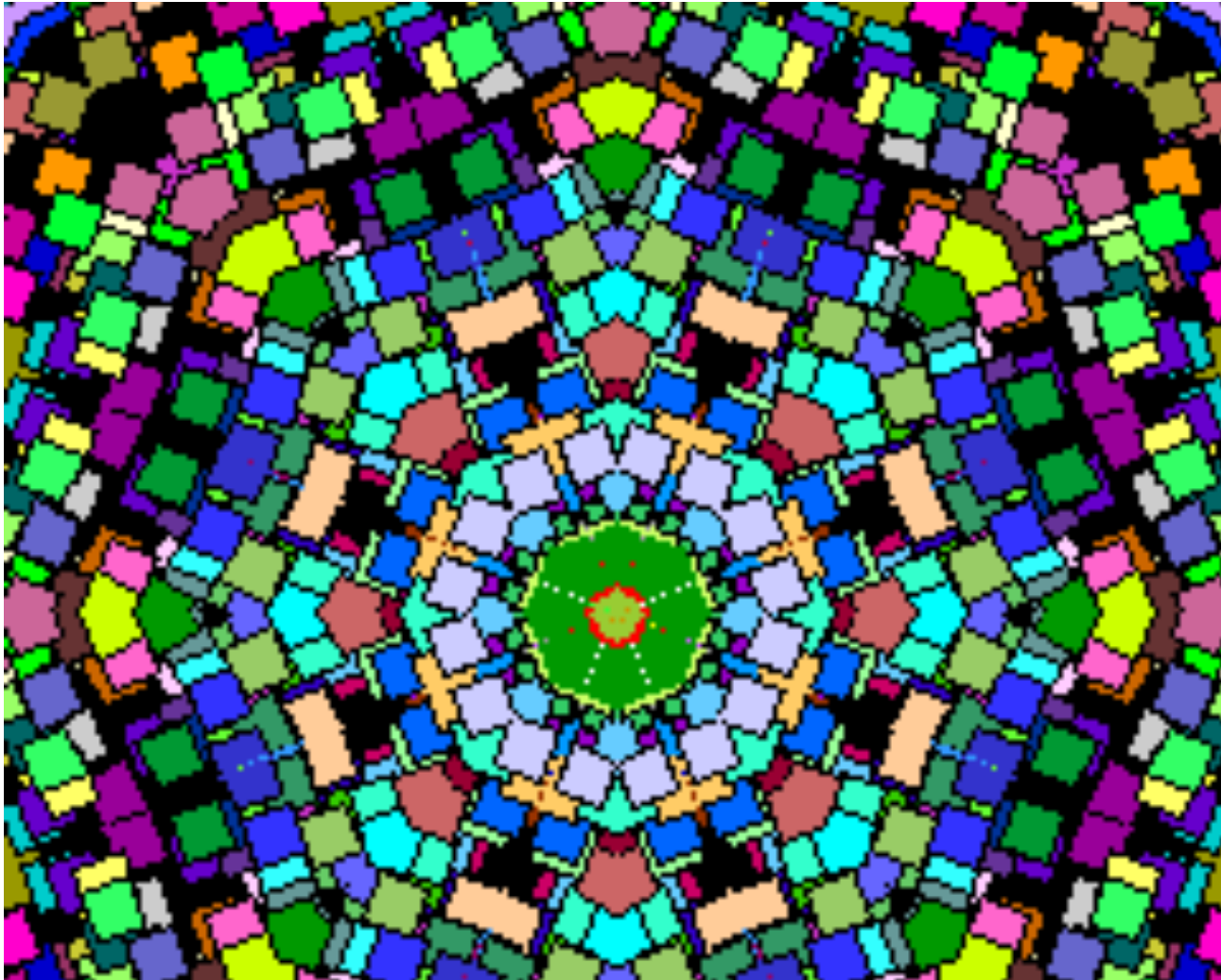

**Admiring the character of Christ  
is like looking through a kaleidoscope:  
you never seem to run out of patterns to admire.**

- Law
- Church
- Family and others
- **God's Goodness**
  - Overwhelming and Awesome
  - Jesus painted pictures to show us the Pattern
  - The Law is Good, but is the Law absolute?
  - Examine the depth of the Pattern
  - Jesus is the Image of the Pattern of Truth (God)
  - We must match the image of Christ
  - **Following examples of Christ**
  - How good do we fit the Pattern?
- Personal - Patterning ourselves after God

# **We can follow the Patterns of the apostles**

**Follow my example, as I follow the example of Christ.**

**1 Corinthians 11:1**

**We needed the physical example of Christ to see God.  
We also need the physical example of others to see Christ.**

**Children look up to us,  
and this helps “bootstrap” the image of God to them.**

# **We can follow the Patterns of the apostles**

**Whatever you have  
learned or  
received or  
heard from me, or  
seen in me —  
put it into practice.**

**And the God of peace will be with you.**

**Philipians 4:9**

# **We can follow the examples that we see**

**Liberty Mutual Insurance commercial where people see others do good and are motivated to do good as well.**

**We see the Pattern of Good that passes from one person to another**

**We can have other good examples,  
but we must be careful who we follow.**



**Dad taking me to the barber shop for a haircut like his**



# **The Pattern may be invisible, but we can see it** <sup>23</sup>

**... we fix our eyes not on what is seen,  
but on what is unseen.**

**For what is seen is temporary,  
but what is unseen is eternal.**

**2 Corinthians 4:17-18**

**We show visible patterns as an example, but the character  
of God is invisible except through His Actions  
And the life of His Son, Jesus Christ.**

# An Example of The Pattern of Good

**Religion that God our Father accepts  
as pure and faultless is this:  
to look after orphans and widows in their distress and  
to keep oneself from being polluted by the world.**

**James 1:27**

# God prepared a pattern of Good works for us to do<sup>23</sup>

For we are God's workmanship,  
**created in Christ Jesus to do good works,**  
which God prepared **in advance** for us to do.

**Ephesians 2:10**

# Changing the Pattern in Resurrection is the Goal<sup>23</sup>

**I declare to you, brothers,**

**that flesh and blood cannot inherit the kingdom of God,  
nor does the perishable inherit the imperishable.**

**Listen, I tell you a mystery:**

**We will not all sleep, but we will all be changed —  
in a flash, in the twinkling of an eye, at the last trumpet.**

**For the trumpet will sound,**

**the dead will be raised imperishable,  
and we will be changed.**

**For the perishable must clothe itself with the imperishable,  
and the mortal with immortality.**

**1 Corinthians 15:50-53**

- Law
- Church
- Family and others
- **God's Goodness**
  - Overwhelming and Awesome
  - Jesus painted pictures to show us the Pattern
  - The Law is Good, but is the Law absolute?
  - Examine the depth of the Pattern
  - Jesus is the Image of the Pattern of Truth (God)
  - We must match the image of Christ
  - Following examples of Christ
  - **How good do we fit the Pattern?**
- Personal - Patterning ourselves after God

# **Goodness of Fit, or How Well Does Goodness Fit our Heart?**

**You have created us for Yourself,  
and our heart is not quiet  
until it rests in You.**

**Augustine**

**We have a space in our heart  
that can only be filled by God.  
Good is the only thing that fits.**

**It is like a puzzle  
that needs a missing piece to be complete.**

**In whatever we think is missing in our life,  
we must realize that our most desperate need is God.**

# Goodness of Fit, or How Well Does Goodness Fit our Heart?

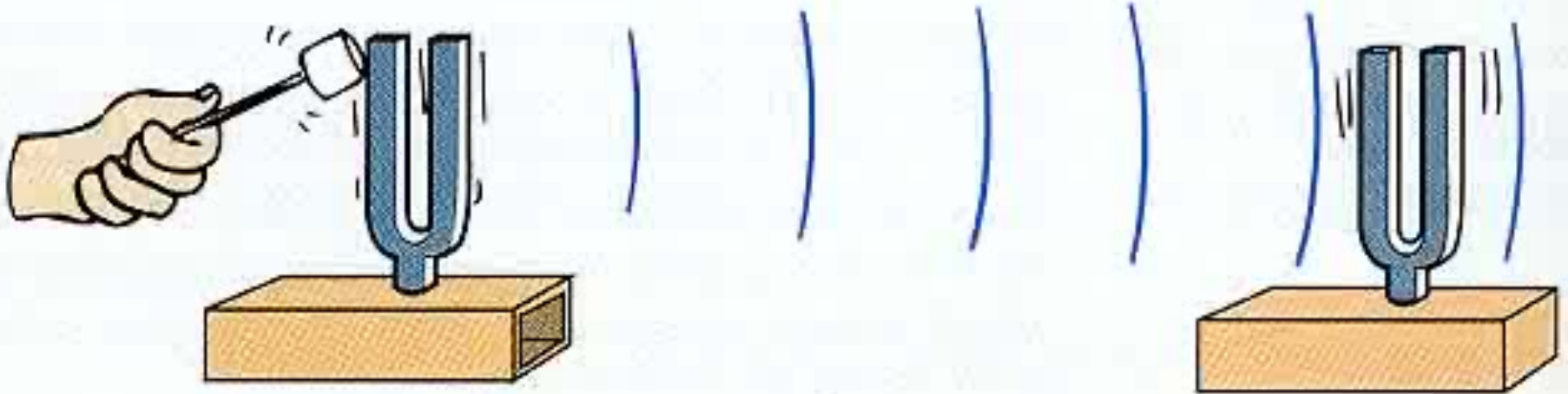

**Good must resonate in our hearts,  
like sound in a tuning fork.**

**When we see the Great Good, it must stop us in our tracks!**

**Satan tried to offer something that extended  
beyond God's Good (to Eve in the Garden).**

**David Elrod**

**We must not reach beyond God's limit --  
there is really nothing better, only an illusion.**



**We must adjust to changing times,  
but still hold to unchanging principles.**

**Miss Julia Coleman**

- Law
- Church
- Family and others
- **God's Goodness**
  - Overwhelming and Awesome
  - Jesus painted pictures to show us the Pattern
  - The Law is Good, but is the Law absolute?
  - Examine the depth of the Pattern
  - Jesus is the Image of the Pattern of Truth (God)
  - We must match the image of Christ
  - **Following examples of Christ**
  - How good do we fit the Pattern?
- Personal - Patterning ourselves after God

# **We can follow the Patterns of the apostles**

**Follow my example, as I follow the example of Christ.**

**1 Corinthians 11:1**

**We needed the physical example of Christ to see God.  
We also need the physical example of others to see Christ.**

**Children look up to us,  
and this helps “bootstrap” the image of God to them.**

## We have to be careful, though...

I appeal to you, brothers,  
in the name of our Lord Jesus Christ,  
that all of you agree with one another  
so that there may be **no divisions** among you and  
that you may be **perfectly united** in mind and thought.

My brothers, some from Chloe's household  
have informed me that there are **quarrels** among you.

What I mean is this:

One of you says, "I follow Paul";  
another, "I follow Apollos";  
another, "I follow Cephas";  
still another, "I follow Christ."

said with superiority?

1 Corinthians 1:10-12

**Is Christ divided?**

**Was Paul crucified for you?**

**Were you baptized into the name of Paul?**

**For Christ did not send me to baptize,**

**but to preach the gospel —**

**not with words of human wisdom,**

**lest the cross of Christ be emptied of its power.**

**1 Corinthians 1:13-14, 17**

# **We all ultimately follow Christ**

**So then, no more boasting about men!**

**All things are yours,  
whether Paul or Apollos or Cephas  
or the world or life or death  
or the present or the future —  
all are yours,  
and you are of Christ,  
and Christ is of God.**

**1 Corinthians 3:21-23**

# **1 Corinthians 1-4 are a lesson in the True Pattern<sup>24</sup>**

**For the message of the cross  
is foolishness to those who are perishing,  
but to us who are being saved it is the power of God.**

**1 Corinthians 1:18**

**Man looked for strength: God gave an infant.  
Man looked for nobility: God came through a manger.  
Man looked for power/royalty: God gave a crucified Savior.**

**Where is the pattern that man would have generated?**

**For the foolishness of God is wiser than man's wisdom,  
and the weakness of God is stronger than man's strength.**

**1 Corinthians 1:25**

# **The Pattern may be invisible, but we can see it** <sup>24</sup>

**... we fix our eyes not on what is seen,  
but on what is unseen.**

**For what is seen is temporary,  
but what is unseen is eternal.**

**2 Corinthians 4:17-18**

**We show visible patterns as an example, but the character  
of God is invisible except through His Actions  
And the life of His Son, Jesus Christ.**



# **We must be able to see God's Pattern**

**We do, however, speak a message of wisdom among the mature, but not the wisdom of this age or of the rulers of this age, who are coming to nothing.**

**No, we speak of God's secret wisdom, a wisdom that has been hidden and that God destined for our glory before time began.**

**None of the rulers of this age **understood** it, for if they had, they would not have crucified the Lord of glory.**

**1 Corinthians 2:6-8**

# We cannot imagine the full glory of it!

However, as it is written:

"No eye has seen,

no ear has heard,

no mind has conceived

what God has prepared for those who love him" —

but God has **revealed** it to us by his Spirit.

1 Corinthians 2:9-10

**We may think we are the leaders,  
but we must still follow those who see more clearly**

**We are fools for Christ, but you are so wise in Christ!**

**We are weak, but you are strong!**

**You are honored, we are dishonored!**

**...**

**Up to this moment we have become the scum of the earth,  
the refuse of the world.**

**Even though you have ten thousand guardians in Christ,  
you do not have many fathers, for in Christ Jesus I  
became your father through the gospel.**

**Therefore I urge you to imitate me.**

**1 Corinthians 4:10-16**

# Return to the idea of Unity within the Pattern

I appeal to you, brothers,  
in the name of our Lord Jesus Christ,  
that all of you agree with one another  
so that there may be **no divisions** among you and  
that you may be **perfectly united** in mind and thought.

1 Corinthians 1:10

In him the whole building is joined together  
and rises to become a holy temple in the Lord.

Ephesians 2:21

The building must perfectly joined –  
no friction, no sharp edges (no porcupines).  
The mortar between us bricks is the love of God.

# **You do not need perfect agreement, but Harmony<sup>24</sup>**

**Now you are the body of Christ,  
and each one of you is a part of it.**

**And in the church God has appointed first of all apostles,  
second prophets, third teachers,  
then workers of miracles,  
also those having gifts of healing,  
those able to help others,  
those with gifts of administration, and  
those speaking in different kinds of tongues.**

**Are all apostles? Are all prophets? Are all teachers?  
Do all work miracles? Do all have gifts of healing?  
Do all speak in tongues? Do all interpret?**

**But eagerly desire the greater gifts.**

**2 Corinthians 12:27-31**

**We can be different, but still united**

# We can all contribute in service and worship

24



**And paint a complete, meaningful picture**

**Each piece offers a different perspective**



- Law
- Church
- Family and others
- **God's Goodness**
  - Overwhelming and Awesome
  - Jesus painted pictures to show us the Pattern
  - The Law is Good, but is the Law absolute?
  - Examine the depth of the Pattern
  - Jesus is the Image of the Pattern of Truth (God)
  - We must match the image of Christ
  - Following examples of Christ
  - **How good do we fit the Pattern?**
- Personal - Patterning ourselves after God



**The [Christian] "doctrines"  
are translations into our concepts and ideas  
of that which God has already expressed  
in language more adequate,  
namely the actual  
incarnation,  
crucifixion, and  
resurrection.**

**C. S. Lewis**

- Law
- Church
- Family and others
- **God's Goodness**
  - Overwhelming and Awesome
  - Jesus painted pictures to show us the Pattern
  - The Law is Good, but is the Law absolute?
  - Examine the depth of the Pattern
  - Jesus is the Image of the Pattern of Truth (God)
  - We must match the image of Christ
  - **Following examples of Christ**
  - How good do we fit the Pattern?
- Personal - Patterning ourselves after God

# Still following the followers

**Join with others in following my example, brothers,  
and take note of those  
who live according to the **pattern** we gave you.**

**Philippians 3:17**

- Law
- Church
- Family and others
- **God's Goodness**
  - Overwhelming and Awesome
  - Jesus painted pictures to show us the Pattern
  - The Law is Good, but is the Law absolute?
  - Examine the depth of the Pattern
  - Jesus is the Image of the Pattern of Truth (God)
  - We must match the image of Christ
  - Following examples of Christ
  - **How good do we fit the Pattern?**
- Personal - Patterning ourselves after God

## **Goodness of Fit, or How Well Does Goodness Fit our Heart?**

**You have created us for Yourself,  
and our heart is not quiet  
until it rests in You.**

**Augustine**

**We have a space in our heart  
that can only be filled by God.  
Good is the only thing that fits.**

**It is like a puzzle  
that needs a missing piece to be complete.**

**In whatever we think is missing in our life,  
we must realize that our most desperate need is God.**

# Goodness of Fit, or How Well Does Goodness Fit our Heart?



**Good must resonate in our hearts,  
like sound in a tuning fork.**

**When we see the Great Good, it must stop us in our tracks!**

**We must feel the fit,  
as though we were putting on clothes or shoes**

**You, however, did not come to know Christ that way.  
Surely you heard of him and were taught in him  
in accordance with the truth that is in Jesus.  
You were taught, with regard to your former way of life,  
to **put off your old self**,  
which is being corrupted by its deceitful desires;  
to be made new in the attitude of your minds;  
and to **put on the new self**,  
created to be like God  
in true righteousness and holiness.**

**Ephesians 4:20-24**

**We must feel the fit,  
as though we were putting on clothes or shoes**

**Therefore, as God's chosen people, holy and dearly loved,  
clothe yourselves with  
compassion,  
kindness,  
humility,  
gentleness and  
patience...**

**And over all these virtues put on love,  
which binds them all together in perfect unity.**

**Colossians 3:12**

**This Garment also protects us, helping us deal with life**



# **We must not try to wear something that doesn't fit**<sup>25</sup>

**Many people wear the truth like an ill-fitting shoe.**

**They limp around unhappily,  
with blisters all over their feet,  
but will not change because the shoes cost too much  
or they are thought to be too pretty.**

**We can't actually change our feet,  
but we can certainly change our hearts.**

**We must gird ourselves with the truth,  
and this implies a fitting process.**

**But instead of fitting the truth to us,  
we must change our lives to fit the truth.**

# **We must not give up until the fit is comfortable** <sup>25</sup>

**When we are hiking,  
we must continually check for warm spots;  
these are a warning of blister development.**

**Most people just keep walking  
until it is so bad that they can go any further.**

**Then they never go hiking again.**

**Do not conform any longer to the pattern of this world,  
but be transformed by the renewing of your mind.**

**Romans 12:2a**

# Beauty is in the eye of the Beholder

**When we see a person, place, food, etc...**

**our attraction is largely based on a previous model.**

**We admire those who are beautiful in a “standard” way,**

**but also those who remind us of others**

**with which we have had relationships with first.**

# **A smile can make any face attractive**

**I've never seen a smiling face that was not beautiful.**

**Author Unknown**

**Everyone smiles in the same language.**

**Author Unknown**

**Let us always meet each other with smile, for the smile is the beginning of love.**

**Mother Teresa**

**Every man over forty is responsible for his face.**

**Abraham Lincoln**

# **We are constantly checking against inner patterns<sup>25</sup>**

**The pattern we see that “clicks”  
is something that we have dreamed about --  
that we have a fantasy about.**

**It should be that our greatest fantasy is for the Good,  
to be with God; then good thoughts  
“click” into that and reinforce good behavior.**

**Then we would live more like Christ.**

# **Do you believe in love at first sight?**

**We sometimes encounter people,  
even perfect strangers,  
who begin to interest us at first sight,  
somehow suddenly,  
all at once,  
before a word has been spoken.**

**Fyodor Dostoevsky**

**Jesus looked at the rich young ruler and loved him.**

**One encounter with Jesus Christ  
is enough to change you, instantly, forever.**

**Luis Palau**

**True love (God's love) can be (and should be) at first sight!**

# **We should be satisfied to see God**

**And I —**

**In righteousness I will see your face;**

**when I awake,**

**I will be satisfied with seeing your likeness.**

**Psalm 17:15**

# **God seeks worshipers who see the True Good**

25

**God seeks a certain pattern in us**

**Yet a time is coming and has now come  
when the true worshipers will worship the Father  
in spirit and truth,  
for they are the kind of worshipers the Father seeks.**

**God is spirit,  
and his worshipers must worship  
in spirit and in truth.**

**John 4:23-24**

**We must not try to force fit God into our own desires.**



**The most pathetic person in the world  
is someone who has sight, but has no vision.**

**Helen Keller**

- Law
- Church
- Family and others
- **God's Goodness**
  - Overwhelming and Awesome
  - Jesus painted pictures to show us the Pattern
  - The Law is Good, but is the Law absolute?
  - Examine the depth of the Pattern
  - Jesus is the Image of the Pattern of Truth (God)
  - We must match the image of Christ
  - Following examples of Christ
  - **How good do we fit the Pattern?**
- Personal - Patterning ourselves after God

# Goodness of Fit, or How Well Does Goodness Fit our Heart?

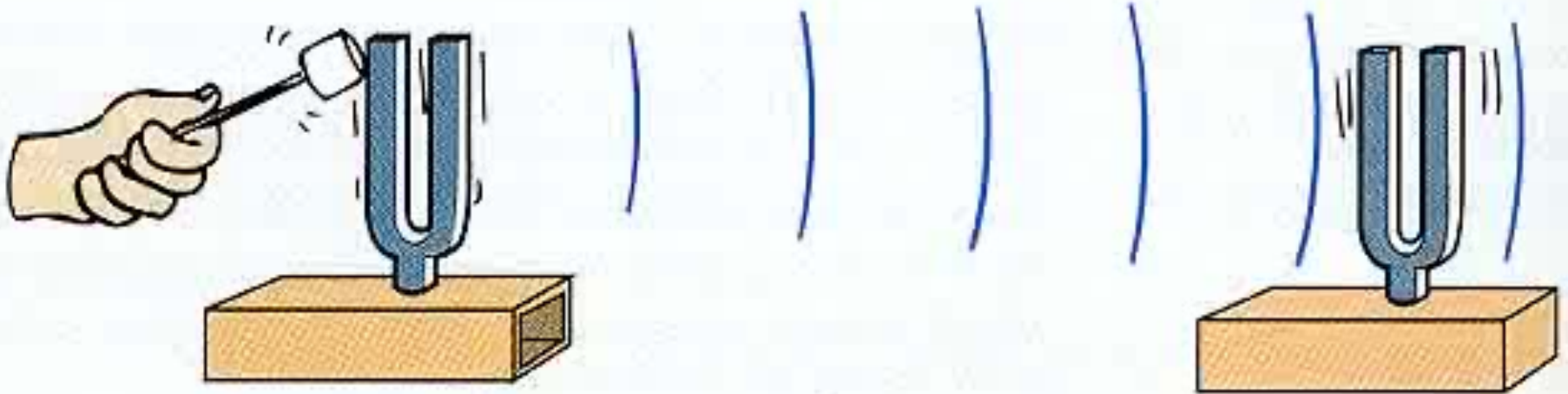

**Good must resonate in our hearts,  
like sound in a tuning fork.**

**When we see the Great Good, it must stop us in our tracks!**

# God seeks worshipers who see the True Good <sup>26</sup>

**God seeks a certain pattern in us**

**Yet a time is coming and has now come  
when the true worshipers will worship the Father  
in spirit and truth,  
for they are the kind of worshipers the Father seeks.**

**God is spirit,  
and his worshipers must worship  
in spirit and in truth.**

**John 4:23-24**

**We must not try to force fit God into our own desires.**

# God has an infinite capacity to accept our individuality in context of His Pattern

Consider the complex but beautiful patterns of the integration of our hearts in heaven

If we played three CDs of praise at the same time, we'd have a cacophony of noise that would drive us crazy.

This was totally different.

Every sound blended,

and each voice or instrument enhanced the others.

Don Piper, 90 Minutes in Heaven

How do jazz groups play together?

Seemingly they need a strict script;

how can it be beautiful if there is no strict pattern?

# Man has some natural capability to see the Pattern<sup>26</sup>

**For it is not those who hear the law  
who are righteous in God's sight,  
but it is those who obey the law  
who will be declared righteous.**

**(Indeed, when Gentiles, who do not have the law,  
do by nature things required by the law,  
they are a law for themselves,  
even though they do not have the law,  
since they show that the requirements of the law  
are **written on their hearts**,  
their consciences also bearing witness,  
and their thoughts now accusing,  
now even defending them.)**

**Romans 2:13-15**

# He can clearly see it if he looks

The wrath of God is being revealed from heaven against all the godlessness and wickedness of men who suppress the truth by their wickedness, since what may be known about God is plain to them, because God has made it plain to them.

For since the creation of the world God's invisible qualities — his eternal power and divine nature — have been **clearly seen**, being understood from what has been made, so that men are **without excuse**.

**Romans 1:18-20**

## He sometimes exchanges it for a False one

For although they knew God,  
they neither glorified him as God  
nor gave thanks to him,  
but their thinking became futile  
and their foolish hearts were darkened.

Although they claimed to be wise,  
they became fools  
and **exchanged** the glory of the immortal God  
for images made to look  
like mortal man and birds and animals and reptiles.

They **exchanged** the truth of God for a lie,  
and worshiped and served created things  
rather than the Creator —  
who is forever praised.

Romans 1:21-23, 25



**But they would not listen  
and were as stiff-necked as their fathers,  
who did not trust in the LORD their God.**

**They rejected his decrees and the covenant  
he had made with their fathers  
and the warnings he had given them.**

**They followed **worthless** idols  
and themselves became **worthless**.**

**They imitated the nations around them  
although the LORD had ordered them,  
"Do not do as they do,"  
and they did the things the LORD  
had forbidden them to do.**

**Who is the liar?**

**It is the man who denies that Jesus is the Christ.**

**Such a man is the antichrist —  
he denies the Father and the Son.**

**1 John 2:22**

# Calvin and Hobbes liked to play "Opposite Day" <sup>26</sup>



# **We must turn the opposite way from our Sin**

**If we have been united with him like this in his death,  
we will certainly also be united with him  
in his resurrection.**

**For we know that our old self was crucified with him  
so that the body of sin might be done away with,  
that we should no longer be slaves to sin --  
because anyone who has died has been freed from sin.**

**Romans 6:5-7**

# **We exchange our self for the Spirit of God...**

**For through the law I died to the law  
so that I might live for God.**

**I have been crucified with Christ and I no longer live,  
but Christ lives in me.**

**The life I live in the body,  
I live by faith in the Son of God,  
who loved me and gave himself for me.**

**Galatians 2:19-20**

**We must carve out a place where God's Pattern will fit**

# World Design Experiment

**Pretend that you are an angel in training,  
and that in your schoolwork you are asked to  
design a world.**

**Objective: To increase Good (in a world of Evil)**

**Given: Man is made in God's Image  
Man has Free Will  
There is an Evil Presence**

**Approach: Cause people to love each other  
and not do evil (hurt) to each other**

**Conclusion: No better plan to inspire love exists!**

# Thought Question

**What if only those who truly in love  
could have children?**

**Would the human race survive?**

- **Law**
- **Church**
- **Family and others**
- **God's Goodness**
  - **Overwhelming and Awesome**
  - **Jesus painted pictures to show us the Pattern**
  - **The Law is Good, but is the Law absolute?**
  - **Examine the depth of the Pattern**
  - **Jesus is the Image of the Pattern of Truth (God)**
  - **We must match the image of Christ**
  - **Following examples of Christ**
  - **How good do we fit the Pattern?**
- **Personal - Patterning ourselves after God**



**It's our metamorphosis.**

**We've changed from a tail-bearing organism immersed in liquid with eyes on the sides of our heads, a yolk sac, bronchial arches, a one-chambered heart, a snout-like nose, with webbed hands and feet, and become human.**

**If you could relate this to a butterfly,  
would it believe such a transition is possible?**

**Gerald Schroeder**

**We have a major change to make**

# Being Born Anew

In reply Jesus declared,

"I tell you the truth, no one can see the kingdom of God unless he is **born again**."

**John 3:3**

For you have been **born again**,

not of perishable seed,

but of imperishable,

through the living and enduring word of God.

**1 Peter 3:23**

**Our personal pattern must undergo a complete change**

## **New people (not “chosen people”)**

Here there is no Greek or Jew, circumcised or uncircumcised, barbarian, Scythian, **slave or free**, but Christ is all, and is in all. Colossians 3:11

## **New Body**

So will it be with the resurrection of the dead. The body that is sown is perishable, it is raised imperishable; it is sown in dishonor, it is raised in glory; it is sown in weakness, it is raised in power; it is sown a natural body, it is raised a spiritual body. 1 Corinthians 15:42-44

## **New Home**

But in keeping with his promise we are looking forward to a new heaven and a new earth, the home of righteousness. 2 Peter 3:13

**The heavenly Pattern will be much different**

**There is nothing in a caterpillar that tells you  
it's going to be a butterfly.**

**R. Buckminster Fuller**

- **Law**
- **Church**
- **Family and others**
- **God's Goodness**
  - **Overwhelming and Awesome**
  - **Jesus painted pictures to show us the Pattern**
  - **The Law is Good, but is the Law absolute?**
  - **Examine the depth of the Pattern**
  - **Jesus is the Image of the Pattern of Truth (God)**
  - **We must match the image of Christ**
  - **Following examples of Christ**
  - **How good do we fit the Pattern?**
- **Personal - Patterning ourselves after God**

# We must test every pattern against the true

If a prophet, or one who foretells by dreams,  
appears among you  
and announces to you a miraculous sign or wonder,  
and **if the sign or wonder of which he has spoken  
takes place,**  
and he says, "Let us follow other gods"  
(gods you have not known)  
"and let us worship them,"  
you must not listen to the words  
of that prophet or dreamer.  
The LORD your God is **testing** you  
to find out whether you **love him**  
**with all your heart and with all your soul.**

Deuteronomy 13:-3

Even a false prophet can be true sometimes

**Examine yourselves to see whether you are in the faith;  
test yourselves.**

**Do you not realize that Christ Jesus is in you —  
unless, of course, you fail the test?**

**2 Corinthians 13:5**

**We must be able to “get it”**

# We must lock ourselves into the Pattern

**So I will always remind you of these things,  
even though you know them  
and are firmly established in the truth you now have.**

**2 Peter 1:12**

**What you heard from me,  
keep as the **pattern** of sound teaching,  
with faith and love in Christ Jesus.**

**2 Timothy 1:13**

**We must be able to **keep** it as well**



**God's truth is indeed absolute,  
but we don't have to know it perfectly here; just "get it".**

**God will transform our thinking in heaven  
to conform to His absolute perfection;  
we can disagree with other now  
and it doesn't affect this.**

**We can be imperfect and His grace will save us,  
and it will ultimately change us.**

**The purpose of the (evil) world is  
to let us rattle around in our sin,  
to find out what it is all about, to "get it",  
so then God can accept us  
and transform us into His perfect kingdom.**

# Many People Don't!

God looks down from heaven  
on the sons of men  
to see if there are **any** who understand,  
**any** who seek God.

Everyone has turned away,  
they have together become corrupt;  
there is **no one** who does good,  
**not**  
**even**  
**one.**

KJV: no, not one!

Psalm 53:2-3

Think of God's disappointment

# Many People Don't Get It!



# **It may take a while**

**Leonardo saw how everything fit into a pattern**

**Leonardo Da Vinci's technique for getting ideas was to close his eyes, relax totally, and cover a sheet of paper with random lines and scribbles.**

**He would then open his eyes and look for images and patterns, objects, faces, or events in the scribble.**

**Many of his inventions came forth unbeckoned from this random scribbling.**

**As Leonardo painted one brush stroke at a time, the pattern would emerge.**

# **An artist can see the complete picture**

**Have you ever watched a real artist at work?**

**They do not draw in the sequence that I would.**

**They work at spots all around the frame,  
filling in what is needed.**

**As Leonardo painted one brush stroke at a time,  
the proper pattern would emerge.**

# Examples of the “Aha!” of Recognition

**PDE: Think of moments in scripture when the illusion evaporated – when the fog lifted and reality set in...**

**Think of Helen Keller, from The Miracle Worker, “getting it” when she finally realized that her teacher was spelling the word “water” (making the connection).**

**Saul sees Samuel – the witch at Endor (bad); 1 Samuel 28  
Gehazi’s eyes opened (good); 2 Kings 6:16-18**

**David -- “you are the man...” (bad); 2 Samuel 12**

**Prophets of Baal, when through Elijah the true God is revealed (bad); 1 Kings 18**

**Instances from the Research Question (good)**

**Judgment, when all is revealed and every knee shall bow (good); Romans 14:11**

# **We must change from the worldly Pattern**

27

**Think of the word “Pattern” as a verb -- becoming...  
See the pattern... Be the pattern... Live the pattern...**

**So from now on we regard no one  
from a worldly point of view.**

**Though we once regarded Christ in this way,  
we do so no longer.**

**Therefore, if anyone is in Christ,  
he is a new creation;  
the old has gone,  
the new has come!**

**2 Corinthians 4:16ff**

**Pattern yourselves in the image of Christ!**

- **Law**
- **Church**
- **Family and others**
- **God's Goodness**
  - **Overwhelming and Awesome**
  - **Jesus painted pictures to show us the Pattern**
  - **The Law is Good, but is the Law absolute?**
  - **Examine the depth of the Pattern**
  - **Jesus is the Image of the Pattern of Truth (God)**
  - **We must match the image of Christ**
  - **Following examples of Christ**
  - **How good do we fit the Pattern?**
- **Personal - Patterning ourselves after God**
- **Conclusion**



## **Temple responsibilities: Numbers 3 (remember the pattern)**

Gershon: care of the tabernacle and tent, its coverings, the curtain at the entrance, the curtains of the courtyard, the curtain at the entrance to the courtyard surrounding the tabernacle and altar, and the ropes — and everything related to their use.

Kohath: care of the ark, the table, the lampstand, the altars, the articles of the sanctuary used in ministering, the curtain, and everything related to their use.

Merari: care of the frames of the tabernacle, its crossbars, posts, bases, all its equipment, and everything related to their use, as well as the posts of the surrounding courtyard with their bases, tent pegs and ropes.

**Gershon, Kohath, and Merari were sons of Levi**

# Packing up and Moving the Tabernacle

**These three groups were given the duty of packing up and moving the Tabernacle and all of its elements and accessories every day, and then setting it back up when the group got to the new camping place.**

**Every day there was the orderly assembly and disassembly according to the Pattern given by God.**

**This is a parallel to the **spiritual renewal** we all need to experience every day.**

# From the Depths of the Heart

In Romans 7, St. Paul says, "The law is spiritual."

What does that mean?

If the law were physical,  
then it could be satisfied by works,  
but since it is spiritual,  
no one can satisfy it unless everything he does  
springs **from the depths of the heart**.

But no one can give such a heart except the Spirit of God,  
who makes the person be like the law,  
so that he actually conceives a heartfelt longing  
for the law and henceforward does everything,  
not through fear or coercion,  
but from a **free heart**.

Martin Luther

**"I love those who love me,  
And those who seek me diligently will find me."**

**Proverbs 8:17**

**We must continue to search for the Pattern of God's Truth**

# Pattern Map

Heb 11?

27

Creation

pattern on the mountain

tabernacle pattern changed

glasses speck kinds

beyond the Golden Rule

intro

review

perception

process

color blind

astig

move

impress

recog aha

1

2

3

4

5

6

7

8

9

beyond the Golden Rule

The Law

The Church

recog face I

recog face II

recog face III

recog face IV

forest trees

covered

delusion

distortion

spin

10

11

12

13

14

15

16

17

18

The Church

God's Goodness

Goodness of Fit

conclusion

illusion

hidden

simplify

interpret

ground

guide

communi-  
cation

strength

balance

19

20

21

22

23

24

25

26

27